

# SG203B.Ia The Resurgence of Sacred Geometry in Science

## Online Module SG 203-B (Interm III-B)

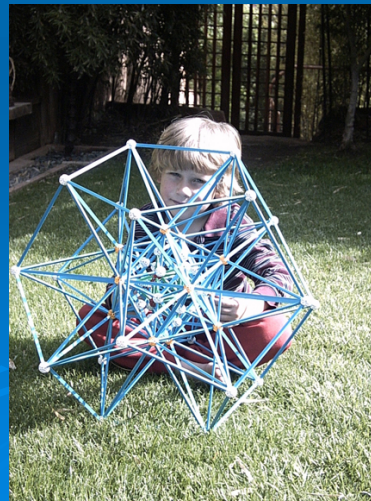
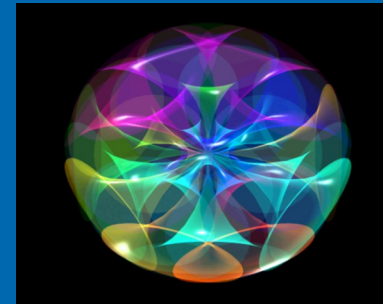
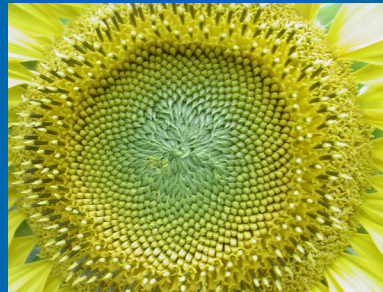
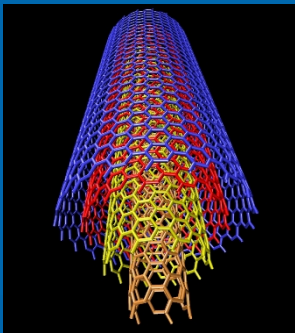
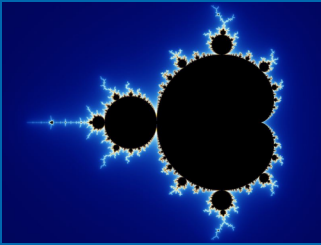

Presented by AYA  
& the School of Sacred Geometry  
P. O. Box 3714  
Sedona, AZ 86340

[www.SchoolOfSacredGeometry.org](http://www.SchoolOfSacredGeometry.org)  
[phi@schoolofsacredgeometry.org](mailto:phi@schoolofsacredgeometry.org)  
[www.starwheels.com](http://www.starwheels.com)



# SG203.Ib Sacred Geometry in Science - Contents

## PART A (SG203-A)

### Introduction

Timeline

### 1. Fractals & Self-Similarity

- 1.1 Ancient Roots of Fractality (1-2)
- 1.2 Simple Iterative Fractals (1-2)
- 1.3 Proto-Fractals (1-3)
- 1.4 Sierpinski Triangle (1-3)
- 1.5 Fractals & B. Mandelbrot (1-3)
- 1.6 The Mandelbrot Set (1-2)
- 1.7 Faces of the M-Set (1-6)
- 1.8 M-Set and Phi (1-3)
- 1.9 Golden Fractals (1-6)
- 1.10 Phi: a Continued Fractal
- 1.11 Chaos Theory & Fractals (1-5)
- 1.12 Fractals in Human Body
- 1.13 Fractals in Nature
- 1.14 Fractal Models (1-2)
- 1.15 Fractals in technology (1-2)
- 1.16 Fractals in Culture
- 1.17 Fractals in Art
- 1.18 A Golden Fractal Universe

### 2. Penta-Symmetries

- 2.1 Penrose Tiling (1-2)
- 2.2 The two Penta-Modules
- 2.3 Penrose Tiling 2D (1-2)
- 2.4 Penrose Tiling 3D (1-4)
- 2.5 Quasicrystals - The Story (1-3)
- 2.6 Quasicrystals - Diffusion Patterns
- 2.7 Quasicrystals - R & D (1-2)

2.8 Quasicrystals - Design (1-2)

2.9 Water Micro Clusters (1-3)

2.10 Fullerenes - Buckyball (1-3)

2.11 Fullerenes - Variations (1-2)

2.12 Fullerenes - Applications (1-2)

### 3. Platonic Models in Science

- 3.1 The Nesting of the Cosmic Figures
- 3.2 The All Five Puzzle
- 3.3 The Dodeca-Icosa Doctrine
- 3.4 Kepler's Cosmic Cup
- 3.5 Felix Klein and the Icosahedron
- 3.6 New model Atom (1-4)
- 3.7 Platonic Wave Resonance
- 3.8 Oscillons & Solitons (1-2)
- 3.9 Rotating Platonics Atom Model
- 3.10 Atomic Nucleus Moon Model (1-3)
- 3.11 Tetrahedral Physics (1-2)
- 3.12 Platonic Chemistry (1-4)
- 3.13 Platonic Cosmology (1-2)

## PART B (SG203-B)

### 4. Fibonacci/Lucas & PHI

- 4.1 Fibo/Lucas Reminder (1-3)
- 4.2 Fibo in Maths (1-3)
- 4.3 Golden Maths (1-4)
- 4.4 Pascal Triangle (1-4)
- 4.5 Fibo in Technology (1-2)
- 4.6 Fibo in Nature (1-5)
- 4.7 Fibo Reflections

### 5. Vortex Science

- 5.1 The Insights of V. Schauburger (1-2)
- 5.2 What is Implosion? (1-2)
- 5.3 Theodor Schwenk (1-2)
- 5.4 What is a Vortex? (1-2)
- 5.5 Walter Russell (1-2)
- 5.6 Lawrence Edwards (1-2)
- 5.7 Golden Vortex (1-5)
- 5.8 Solitonic Vortices
- 5.9 Vortex Gallery (1-3)
- 5.10 Vortex Water (1-5)
- 5.11 Egg-Shape Power (1-2)
- 5.12 Vortex technology (1-2)
- 5.13 Vortex Sculptures

### 6. A Golden Matrix Universe

- 6.1 New Paradigm (1-4)
- 6.2 A Coherent Cosmos
- 6.3 A Non-Local Cosmos (1-2)
- 6.4 A Scale-Invariant Cosmos (1-4)
- 6.5 A Cosmos of In-Formation
- 6.6 The Field (1-3)
- 6.7 A Cosmos of Consciousness
- 6.8 Phi in Quantum (1-2)
- 6.9 E-Infinity / El Naschie (1-3)
- 6.10 Raji Heyrovska (1-4)
- 6.11 Golden Implosion / Dan Winter (1-5)
- 6.12 Spotlights on PHI
- 6.13 Mathematics of Harmony / Russia (1-4)
- 6.14. Cosmic Harmonics

### Conclusion

# SG203.Ic Sacred Geometry in Science

## PART B:

Chapter 4: Fibonacci/Lucas & PHI

Chapter 5: Vortex Science

Chapter 6: A Golden Matrix Universe



All contents (texts, concepts, images, diagrams...)

© Aya, Aya Productions & StarWheel Foundation.

*We have acknowledged image and text credits (with hyperlinks) to the best of our ability.*

*Kindly contact us for omissions or corrections.*

[phi@schoolofsacredgeometry.org](mailto:phi@schoolofsacredgeometry.org)

## SG203.4 Chapter 4. Fibonacci/Lucas in Science



The following pages are a gallery of examples, from various scientific disciplines, showing the formative, fractal, self-organization provided by the Fibonacci/Lucas resonance in many natural systems, as uncovered by contemporary science.

In this chapter, instead of looking at fixed symmetries (like pentagonal), we are looking at dynamic processes (linear & non-linear) that display proportions averaging the Phi Ratio.

Some of these aspects will be only mentioned for reference as they are going to be extensively covered in following modules: phyllotaxis and the Phi-based growth angle, Phi proportions in the human body and nature, Fibo/Lucas resonance in the DNA, celestial & cosmological Phi harmonics...



# SG203.4.1.1 Fibo/Lucas Reminder (1) Fibonacci Series

1-1-2-3-5-8-13-21-34-55-89-144-233-377...

↑ Each term is the sum of the two preceding terms:  
Example:  $34 = 21 + 13$

↑ Each term divided by the previous one gives a progressively better approximation for PHI, the Golden Ratio:  
Examples:  $144 / 89 = 1.617977...$   
and  $233 / 144 = 1.618055$   
(accurate numerical value for  $\Phi$  to 4 decimals)

Leonardo of Pisa →  
aka Fibonacci  
(1170 - 1240)

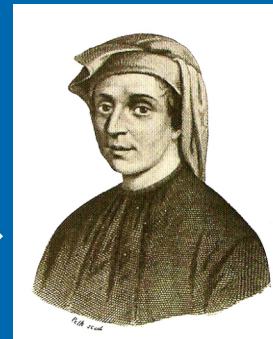

$$\begin{aligned} \varphi &= \varphi \\ \varphi^2 &= \varphi + 1 \\ \varphi^3 &= 2\varphi + 1 \\ \varphi^4 &= 3\varphi + 2 \\ \varphi^5 &= 5\varphi + 3 \\ \varphi^6 &= 8\varphi + 5 \\ \varphi^7 &= 13\varphi + 8 \\ \varphi^8 &= 21\varphi + 13 \\ \varphi^9 &= 34\varphi + 21 \\ \varphi^{10} &= 55\varphi + 34 \\ \varphi^{11} &= 89\varphi + 55 \\ \varphi^{12} &= 144\varphi + 89 \\ \varphi^{13} &= 233\varphi + 144, \text{ etc.} \end{aligned}$$

↑ The powers of Phi (1.618...) defined as Fibonacci numbers.

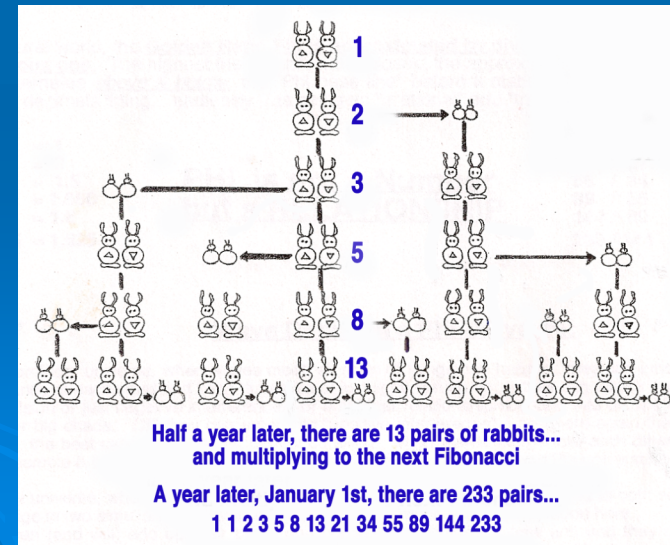
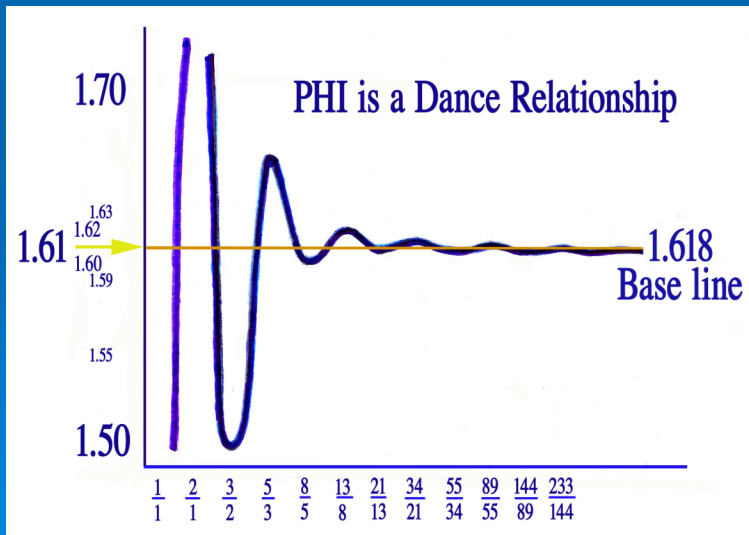

## SG203.4.1.2 Fibo/Lucas Reminder (2) Lucas Series

2 - 1 - 3 - 4 - 7 - 11 - 18 - 29 - 47 - 76 - 123 - 199 - 322 - 521...

Francois Edouard Anatole Lucas (1842-1891) was a 19th century French mathematician whose name was given to the Lucas Series - which is quite fair as Lucas gave the name "Fibonacci Numbers" to the series studied by Leonardo of Pisa in the 12th-13th century.

The Lucas series is defined almost identically to the Fibonacci series, except that the Lucas series begins with 2 and 1 instead of 1 and 1.

The Lucas series converges to PHI just like the Fibonacci series, only in a slower way:

Comparative examples of PHI Convergence:  
 Fibonacci:  $233 / 199 = 1.618055$   
 (closer to PHI and faster)  
 Lucas:  $322 / 199 = 1.618090$   
 (not as exact and not as fast)

This PHI convergence is true for any Fibonacci-like series starting with any pair of numbers:  
 The limit of growth rate will always be PHI.  
 (See [◆SG104.5](#) "*Lusus Numerorum*")



← The Towers of Hanoi game was invented by Edouard Lucas.

n	Fib(n)	2n	Fib(2n)	k=Fib(2n)/Fib(n)
1	1	2	1	1
2	1	4	3	3
3	2	6	8	4
4	3	8	21	7
5	5	10	55	
6	8	12	144	
7	13	14	377	

← Fib (2n) = Fibonacci numbers in an even position.  
 If we divide Fib (2n) by the regular Fibonacci numbers, we get the "k" series or Lucas series.  
 (Fill in the last 3 numbers.)

### THE TOWERS of HANOI

The objective of the puzzle is to move the entire stack to another rod, following these rules:

- Only one disk may be moved at a time.
- Each move consists of taking the upper disk from one of the rods and sliding it onto another rod.
- No disk may be placed on top of a smaller disk.

#### The Legend of the Towers of Hanoi

There is a legend about a Vietnamese temple which contains a large room with three time-worn posts in it surrounded by 64 golden disks. The priests of Hanoi, acting out the command of an ancient prophecy, have been moving these disks, in accordance with the rules of the puzzle, since that time. According to the legend, when the last move of the puzzle is completed, the world will end.  
 It is not clear whether Lucas invented this legend or was inspired by it.

If the legend were true, and if the priests were able to move disks at a rate of one per second, using the smallest number of moves, it would take them  $2^{64}-1$  seconds or roughly 585 billion years. It would take 18,446,744,073,709,551,615 turns to finish.

## SG203.4.1.3 Fibo/Lucas Reminder (3) Fibo/Lucas Twining

(Fibonacci Series)

0 1 1 2 3 5 8 13 21 34 55 89 144 233 377 610 987 1597 2584

2 1 3 4 7 11 18 29 47 76 123 199 322 521 843 1364 2207 3571

(Lucas series)

F		F																	
1	1	2	3	4	5	7	8	11	13	18	21	29	34	47	55	76	89	123	144
L			L	L		L		L		L		L		L		L		L	
199	233	322	377	521	610	843	987	1364	1597	2207	2584	3571							
L		L		L		L		L		L		L		L		L		L	

Combined Fibo-Lucas: 1.  $L_n = F_{n-1} + F_{n+1}$ , where  $F_{n-1}$  is closest lower Fibo.  
 Examples: Lucas 322 = Fibo 233 + 89 Lucas 1364 = Fibo 987 + 377

2.  $5F_n = L_{n-1} + L_{n+1}$   
 Example:  $5 \times 610 = 3050 = \text{Lucas } 843 + \text{Lucas } 2207$

3. Any Lucas / preceding Fibo two places down  $(F_{n-2}) = \sqrt{5} = 2.236$   
 Examples: Lucas 521 / Fibo 233 = 2.236 Lucas 3571 / Fibo 1597 = 2.240

4. Lucas = Sum of corresponding Fibo +  $F_{n-1} + F_{n-2} + F_{n-3}$   
 Example: Lucas 521 = 233 + 144 + 89 + 55

### Historical Note:

Before Fibonacci wrote his work, the Fibonacci numbers had already been discussed by Indian scholars such as Gopāla (before 1135) and Hemachandra (c. 1150) who had long been interested in rhythmic patterns that are formed from one-beat and two-beat notes or syllables. The number of such rhythms having n beats altogether is  $F(n+1)$ , and hence these scholars both mentioned the numbers 1, 2, 3, 5, 8, 13, 21, ... explicitly. ("Fibonacci Numbers". Wolfram MathWorld).



# SG203.4.2.1 Fibonacci in Maths (1)

## Fibo Everywhere

Smiling note from Aya: if I were a mathematician, this subject would fill an entire module (growing by the day). It has been said that, since the 19th century, the mathematical works devoted to Fibonacci numbers began "to be reproduced like Fibonacci's rabbits". Below are a few pointers.

The FIBONACCI ASSOCIATION (founded in 1963) is a mathematical organization that specializes in the Fibonacci number sequence and related subjects. The FA publishes the Fibonacci Quarterly and holds international conferences every two years. [SG104.5.1]

THE DEEP STRUCTURE OF THE FIBONACCI SERIES. [◆SG105.5.4]  
Similarly, the Lucas series displays a "pulse" of 24, with 2 sets mutually summing to "9".

GENERALIZATION OF THE FIBONACCI NUMBERS [◆SG104.5.7]

FIBONACCI & GOLDEN MATRICES. Applied to Golden cryptography.

HYPERBOLIC FIBONACCI & LUCAS FUNCTIONS. Alexey Stakhov.

FRACTALS. Golden Fractals are based on phi recursion. Examples:

1. Fibonacci numbers in the "bulbs" of the Mandelbrot set. [◆SG203.1]
2. In the Golden Fractals, the reduction factor for "touch without overlap" is exactly Phi or approximated by the Fibonacci series. [◆SG203.1]

GOLDEN STRING. The Golden String (also called the "Rabbit Sequence") is a remarkable sequence of 0s and 1s which is intimately related to the Fibonacci numbers and to Phi and has amazing harmonic properties: 1 0 1 1 0 1 0 1 1 0 1 1 0 1 0 1 1 0 1 0 1 1 0 1 ... [◆SG104.5.6]

DA VINCI CODE. A scrambled version [13, 3, 2, 21, 1, 1, 8, 5] of the first eight Fibonacci numbers appear as one of the clues left by murdered museum curator Jacque Saunière in Dan Brown's novel *The Da Vinci Code* (Brown 2003, pp. 43, 60-61, and 189-192).

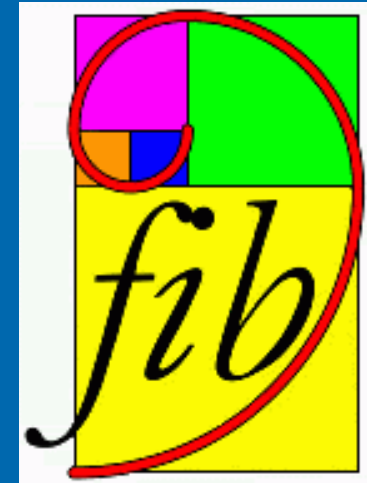

↑ Logo of the Fibonacci Association  
(Note the Golden Spiral and the "Fibonacci Tiling" or Golden Rectangle.)



↑ Fibonacci's statue in Pisa.

## SG203.4.2.2 Fibonacci in Maths (2) Special Properties

There are countless characteristics of the Fibonacci numbers (F numbers)

Amazing, unexpected and curious properties...

Mathematicians are still filling volumes & websites with these discoveries and their applications.

We are presenting a few of them below:

- Ever third F number is EVEN.
- The sum of any ten F numbers is divisible by 11:  
 $21 + 34 + 55 + 89 + 144 + 233 + 377 + 610 + 987 + 1597 = 4147 / 11 = 377$
- The sum of the squares of F numbers = the product of the last and next number in the sequence:  
 $1^2 + 1^2 + 2^2 + 3^2 + 5^2 + 8^2 + 13^2 + 21^2 + 34^2 = 34 \times 55 = 1,870$
- Subtracting the squares of two alternating F numbers creates another F number:  
 $F_7^2 - F_5^2 = 13^2 - 5^2 = 144 = F_{12}$
- The sum of the subscripts of two F numbers whose squares are added gives the subscript of the F number representing their sum:  $F_{10}^2 + F_{11}^2 = 10,946 = F_{21}$
- For any four consecutive F numbers, the difference of the squares of the middle two numbers = the product of the outer two numbers:  
Starting sequence: 13, 21, 34, 55.  $34^2 - 21^2 = 1156 - 441 = 55 \times 13 = 715$
- The product of two alternating F numbers = square of the F number between them, plus or minus 1:  
 $144 \times 377 = 54,288 = 233^2 = 54,289$

... and much more...

So, clearly, we are dealing with a complex matrix,  
intricately weaving harmonic patterns & music-like resonances  
in, through and in between many dimensions.

The Fibonacci Series is not just a line of numbers: it is a poly-D Hyper-MANDALA.

# SG203.4.2.3 Fibonacci in Maths (3) Digit patterns

We have seen [◆SG104.5.4] the Fibonacci "Deep Structure" pattern and its 24 period ("24 Pulse").

In their inspiring book *The Fabulous Fibonacci Numbers* (2007), Alfred Posamentier & Ingmar Lehmann mention other patterns appearing in the final digits of the Fibonacci numbers, the first digits, as well as in the distribution of F numbers in the natural number field.

## Last Digits

- **Last Single Digit.** There is a period of 60 in the pattern of the single last digit of the F numbers. The first set of 60 F numbers ( $F_1 - F_{60}$ ) has the same last digits as the second set ( $F_{61} - F_{120}$ ), the third set ( $F_{121} - F_{180}$ ), the fourth set ( $F_{181} - F_{240}$ ) etc... This pattern continues for each set of 60 F numbers.
- **Last Two Digits.** The last are repeating starting with the 30th F number. So we have a period of 300.
- **Last Three Digits.** Period = 1,500.
- **Last Four Digits.** Period = 15,000.
- **Last Five Digits.** Period = 150,000.

## The First Digits →

Looking at the initial digits of the first 500 F numbers, one finds that the distribution of the nine integers is not even but varies greatly from the most frequent number "1" to the least frequent number "9".

First Digit	(%)
1	30
2	18
3	13
4	9
5	8
6	6
7	5
8	7
9	4

↑ Table of the decreasing frequency of first digit as we go from 1 to 9. (Remember the First Digit Law: ◆SG202.4.1.5)

## Distribution among Natural Numbers

Within the first 100 natural numbers (1 - 100), there are 11 F numbers. Among the next 100 numbers (101 - 200), there is only one F number: 144.

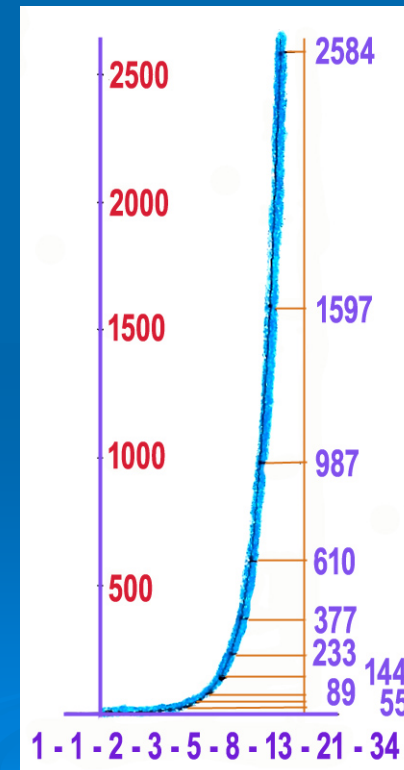

← Curve showing the distribution of the first 18 F numbers.

The 19th F number (6,765) is way off the chart.



# SG203.4.3.1 Golden Maths (1) Generalizations of Phi

In the words of Jay Kappraff (*Beyond Measure*, 2002): "The Fibonacci sequence is merely the beginning of a rich set of relationships associated with the golden mean. Pascal's triangle, despite its deceptive simplicity, is the matrix of these relationships." We will soon see how Pascal's triangle is closely connected with the Fibonacci & Lucas series.

Remember (◆SG 104.5.7) the higher order "Fibonacci" series: the N-nacci numbers. N-nacci constants range from the golden mean 1.618 to 2 and the N-nacci sequences range from the Fibonacci series to the geometric series with common ratio 2. Below are a few recent other generalizations of Phi.

## Generalizations of the Golden Mean

Other generalizations of the golden mean have been proposed.

• **Stakhov.** In the last section of SG203, we will meet with Professor Alexey Stakhov, an Ukrainian scientist, and we will introduce his "Mathematics of Harmony" and his Museum of Harmony. In 1989, Stakhov published a "vertical" generalization of the golden mean, based on the algebraic equation:  $x^{p+1} - x^p - 1 = 0$ . Simply put, Stakhov proved the existence of an infinite number of golden proportions, all of them having the same power of harmony. Stakhov showed that the *golden-p proportions* represented a new class of irrational numbers expressing some unknown properties of the Pascal triangle.

Stakhov introduced the so-called *p-Fibonacci numbers*, which are generated by the recurrence relations  $F(n) = F(n-1) + F(n-p)$ , where  $p = 0, 1, 2, 3, \dots$ . When  $p = 0$ , this recurrence relation generates a classical binary sequence 1, 2, 4, 8, ..., and when  $p = 1$ , the classic Fibonacci numbers. A ratio of two p-Fibonacci numbers creates the golden p-proportions. This is a series of new mathematical constants: 2, 1, 618, 1,465, 1,380... According to Stakhov, the Belarusian philosopher Eduard Soroko used this idea (*Structural Harmony of Systems*, 1984) for his "Law of Structural Harmony of Systems", which greatly expanded the number of new "harmonic proportions", using the golden p-proportions.

A ratio of two p-Fibonacci numbers creates the golden p-proportions.

• **Spinadel.** In 2004, Argentinian mathematician Vera de Spinadel generalized the Fibonacci recursive relation  $F(n+1) = F(n) + F(n-1)$  as follows:  $G(n+1) = pG(n) + qG(n-1)$ , where p and q are natural numbers. The algebraic expression  $x^2 - px - q = 0$  gives an infinite set of positive quadratic irrationals for the different values of p and q. Together these make the *Metallic Means Family* (MMF): when  $p = q = 1$ , we have our classic golden mean (see table →)

p	q	Mean
1	1	Golden
2	1	Silver
3	1	Bronze
1	2	Copper
1	3	Nickel

• **PV numbers.** The Pisot-Vijayaraghavan (PV) numbers are the positive roots of an algebraic equation with partial cases of the golden mean (pentadeca quasi-lattices), the silver mean (octagonal quasi-lattice) and  $PV = 1 + \sqrt{3}$  (dodecagonal quasi-lattice). The powers of PV numbers approach integers at an exponential rate.

• **Gazale.** Egyptian-born mathematician Midhat Gazale proposed a new equation which generalizes the Binet formula for Fibonacci m-numbers and allows the representation of all Fibonacci & Lucas numbers by a golden m-proportion.

• **Kocer, Tuglu, Stakhov.** Introduction of a new class of generalized Fibonacci and Lucas (p,m)-numbers which are used in theoretical physics and computer science.

# SG203.4.3.2 Golden Maths (2)

## Hyperbolic F/L Functions

In contrast to the classical hyperbolic functions, the Hyperbolic Fibonacci & Lucas functions have numerical analogs - the classical Fibonacci & Lucas numbers. Below are images from Dr. Stakhov's analysis.

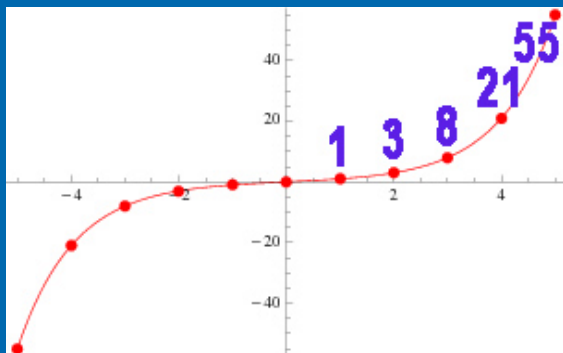

Hyperbolic Fibonacci Sine  
 $sFh(x) = (\Phi^{2x} - \Phi^{-2x}) / \sqrt{5}$

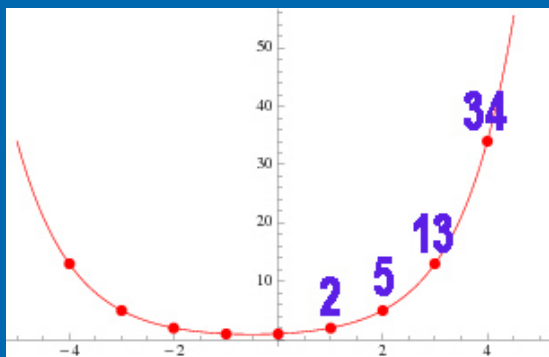

Hyperbolic Fibonacci Cosine  
 $cFh(x) = [(\Phi^{2x+1} + \Phi^{-(2x+1)})] / \sqrt{5}$

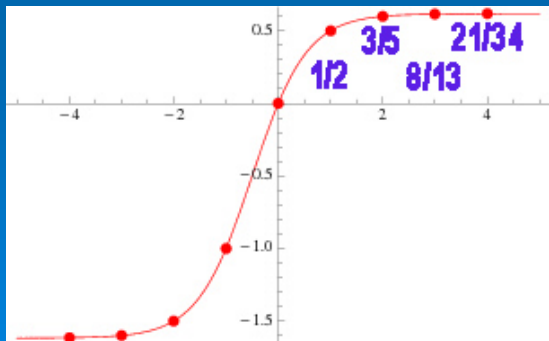

Hyperbolic Fibonacci Tangent  
 $tFh(x) = \Phi (\Phi^{4x} - 1) / \Phi^{(4x+1)} + 1$

← Graphs from Wolfram Math.

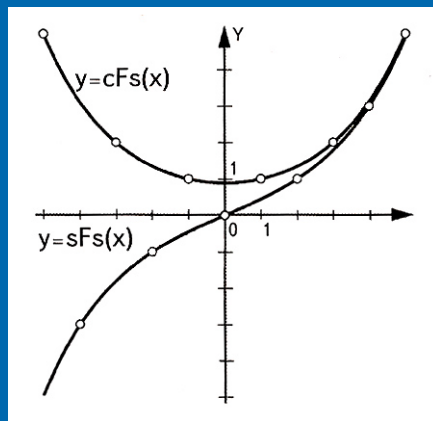

↑ Hyperbolic Fibonacci sine & cosine functions

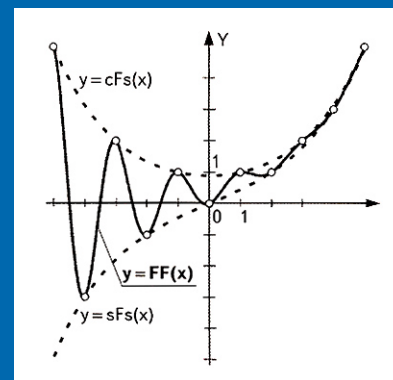

↑ The hyperbolic Fibonacci sine & cosine functions are the envelopes of the "quasi-sine" Fibonacci function

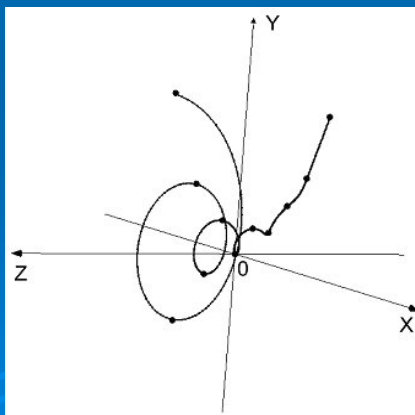

↑ The quasi-sine Fibo function defines a 3D Fibonacci Spiral.

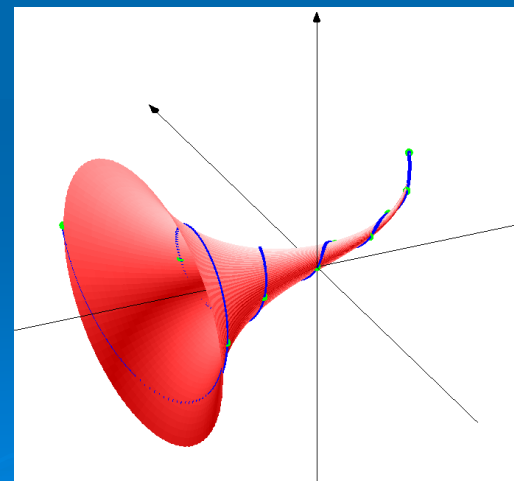

↑ The "Golden Shofar", a 3D Fibonacci volume

# SG203.4.3.3 Golden Maths (3)

## Hyper 7-Tiling

The order-3 heptagonal tiling is a regular tiling of the hyperbolic plane. It is represented by Schläfli symbol of  $\{7,3\}$  = three (3) regular heptagons (7) around each vertex. This tiling is related to the Fibonacci numbers and illustrates exponential growth.

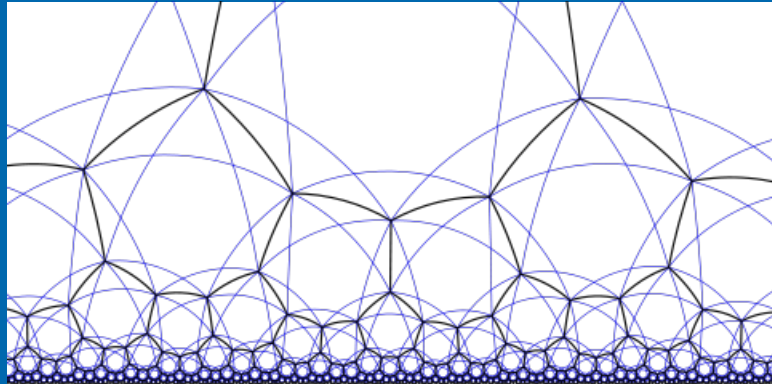

↑ Heptagonal Tiling in a Poincaré half-plane model.

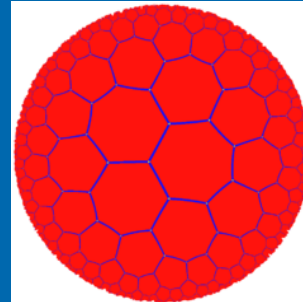

↑ Poincaré disk model of the hyperbolic plane

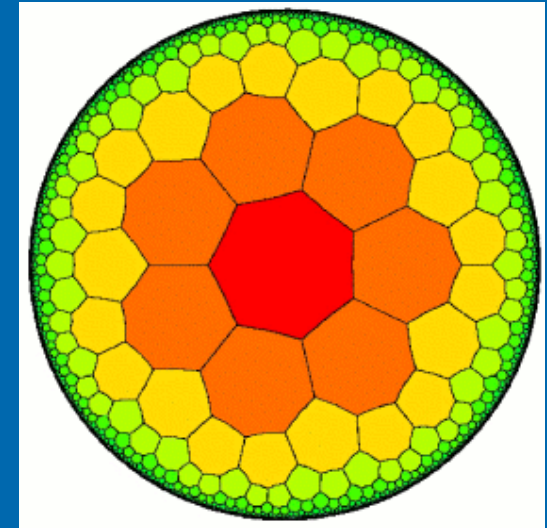

↑ The "*Klein quartic*" is the geometrical name for hyperbolic 7-tiling.

It can be viewed as an extension of the concept of the Platonic solids to a hyperbolic heptagonal tiling.

In the *Klein quartic*, the number of heptagons in the *n*th "ring" is exactly 7 times the 2*n*th Fibonacci number ↓

n	Tiles in <i>n</i> th layer	2 <i>n</i> th Fibonacci number
1	7	1
2	21	3
3	56	8
...	...	...
8	6909	987

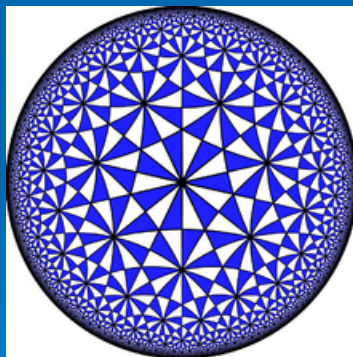

↑ Subdivision into smaller triangles form a Hurwitz surface. The *Klein quartic* is the smallest Hurwitz surface.

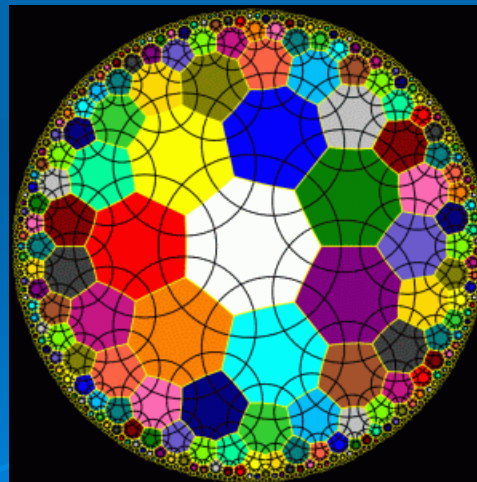

↑ A circle subdivision of the hyperbolic 7-Tiling (Klein quartic).



# SG203.4.3.4 Golden Maths (4) A Base-Phi Number System

In 1957, a young 12-years old American mathematician George Bergman published an article: *A Number System with an Irrational Base*. In Bergman's system, all numbers, including natural, rational and irrational, can be represented by the golden mean, an irrational number acting as the progenitor of all numbers.

One of the unique properties of the golden ratio is that for any non-negative real number there is a unique set of nonconsecutive integer powers of  $\Phi$  that add up to n.

$$\text{Examples: } 30 = \Phi^7 + 1/\Phi + 1/\Phi^3 + 1/\Phi^5 + 1/\Phi^8$$

$$2002 = \Phi^{15} + \Phi^{13} + \Phi^{10} + \Phi^2 + 1/\Phi^2 + 1/\Phi^{11} + 1/\Phi^{16}$$

Decimal	Powers of $\phi$	Base $\phi$
1	$\phi^0$	1
2	$\phi^1 + \phi^{-2}$	10.01
3	$\phi^2 + \phi^{-2}$	100.01
4	$\phi^2 + \phi^0 + \phi^{-2}$	101.01
5	$\phi^3 + \phi^{-1} + \phi^{-4}$	1000.1001
6	$\phi^3 + \phi^1 + \phi^{-4}$	1010.0001
7	$\phi^4 + \phi^{-4}$	10000.0001
8	$\phi^4 + \phi^0 + \phi^{-4}$	10001.0001
9	$\phi^4 + \phi^1 + \phi^{-2} + \phi^{-4}$	10010.0101
10	$\phi^4 + \phi^2 + \phi^{-2} + \phi^{-4}$	10100.0101

The name *Phinary* number system has been proposed, using of course *Phigits*.

Evaluate any number in the Phi base system: [here](#)

In the words of A. Stakhov: "Numeral systems with irrational radices are among the most important mathematical discoveries... Bergman's system and its generalization (the codes of the golden p-proportions) form a new constructive definition for real numbers... This new theory of real numbers can open the way to highly original computer and measurement projects."

Stakhov has proposed an original ternary number system called the *Ternary mirror-symmetrical number system*. It is a synthesis of the classical ternary number system and the number system with an irrational base called Bergman's number system. The main engineering result is a development of an original matrix and pipeline ternary mirror-symmetrical adder, which can be used for fast addition and multiplication in digital signal processors.

## A NUMBER SYSTEM WITH AN IRRATIONAL BASE

George Bergman

The reader is probably familiar with the binary system and the decimal system and probably understands the basis for any others of that type, such as the trinary or duodecimal. However, I have developed a system that is based, not on an integer, or even a rational number, but on the irrational number  $\tau$  (tau), otherwise known as the "golden section", approximately 1.618033989 in value, and equal to  $(1 + \sqrt{5})/2$ .

In order to understand this system, one must comprehend two peculiarities of the number  $\tau$ . They are based on tau's distinctive property 1 that

$$\tau^n = \tau^{n-1} + \tau^{n-2}$$

(a.) Take any approximation ( $A_1$ ) of  $\tau$ . Taking the reciprocal, we get a number ( $a_1$ ) that is proportionately the same distance from  $1/\tau$  as  $A_1$  was from  $\tau$ , but arithmetically nearer. Adding 1, we get a number ( $A_2$ ) that is proportionately nearer  $\tau$  than  $a_1$  was to  $1/\tau$  but arithmetically just as near. Since  $a_1$  is arithmetically nearer than  $A_1$ ,  $A_2$  is nearer in both respects to  $\tau$  than  $A_1$ . Repeating the process of taking the reciprocal and adding 1, we approach  $\tau$ . Now, taking 1 as  $A_1$ , and expressing our approximations of  $\tau$  (i.e.  $A_2, A_3, A_4$ , etc.) as fractions, we get

$$\frac{1}{1} \frac{2}{1} \frac{3}{2} \frac{5}{3} \frac{8}{5} \frac{13}{8} \dots\dots\dots$$

Taking either the numerators or the denominators, we get what is known as the Fibonacci Series, each term of which is formed by adding the two previous terms<sup>2</sup>; for

$$\frac{f_{n+2}}{f_{n+1}} = 1 + \frac{1}{\left(\frac{f_{n+1}}{f_n}\right)} = 1 + \frac{f_n}{f_{n+1}} = \frac{f_{n+1} + f_n}{f_{n+1}} \text{ so } f_{n+2} = f_{n+1} + f_n$$

George Bergman. *Mathematics Magazine*, Vol. 31, No. 2 (Nov. - Dec., 1957), pp. 98-110



# SG203.4.4.2 Pascal Triangle - Fibonacci Numbers (2)

By extending the Fibonacci series in the negative numbers direction as such:

... 13 -8 5 -3 2 -1 1 0 1 1 3 5 8 13 ...,

we can represent the Fibonacci numbers in terms of the members of the Pascal Triangle (left diagram).

If we take the case of  $n = 5$  and substitute in the left figure, we obtain by summation the Fibonacci series.

$$F_n = 1 \cdot F_n$$

$$F_{n+1} = 1 \cdot F_n + 1 \cdot F_{n-1}$$

$$F_{n+2} = 1 \cdot F_n + 2 \cdot F_{n-1} + 1 \cdot F_{n-2}$$

$$F_{n+3} = 1 \cdot F_n + 3 \cdot F_{n-1} + 3 \cdot F_{n-2} + 1 \cdot F_{n-3}$$

$$F_{n+4} = 1 \cdot F_n + 4 \cdot F_{n-1} + 6 \cdot F_{n-2} + 4 \cdot F_{n-3} + 1 \cdot F_{n-4}$$

$$F_{n+5} = 1 \cdot F_n + 5 \cdot F_{n-1} + 10 \cdot F_{n-2} + 10 \cdot F_{n-3} + 5 \cdot F_{n-4} + 1 \cdot F_{n-5}$$

$$F_{n+6} = 1 \cdot F_n + 6 \cdot F_{n-1} + 15 \cdot F_{n-2} + 20 \cdot F_{n-3} + 15 \cdot F_{n-4} + 6 \cdot F_{n-5} + 1 \cdot F_{n-6}$$

$$F_{n+7} = 1 \cdot F_n + 7 \cdot F_{n-1} + 21 \cdot F_{n-2} + 35 \cdot F_{n-3} + 35 \cdot F_{n-4} + 21 \cdot F_{n-5} + 7 \cdot F_{n-6} + 1 \cdot F_{n-7}$$

$$F_{n+8} = 1 \cdot F_n + 8 \cdot F_{n-1} + 28 \cdot F_{n-2} + 56 \cdot F_{n-3} + 70 \cdot F_{n-4} + 56 \cdot F_{n-5} + 28 \cdot F_{n-6} + 8 \cdot F_{n-7} + 1 \cdot F_{n-8}$$

↑ Representation of the Fibonacci numbers using the coefficients of Pascal's Triangle.

$$F_5 = 1 \cdot 5 = 5$$

$$F_6 = 1 \cdot 5 + 1 \cdot 3 = 8$$

$$F_7 = 1 \cdot 5 + 2 \cdot 3 + 1 \cdot 2 = 13$$

$$F_8 = 1 \cdot 5 + 3 \cdot 3 + 3 \cdot 2 + 1 \cdot 1 = 21$$

$$F_9 = 1 \cdot 5 + 4 \cdot 3 + 6 \cdot 2 + 4 \cdot 1 + 1 \cdot 1 = 34$$

$$F_{10} = 1 \cdot 5 + 5 \cdot 3 + 10 \cdot 2 + 10 \cdot 1 + 5 \cdot 1 + 1 \cdot 0 = 55$$

$$F_{11} = 1 \cdot 5 + 6 \cdot 3 + 15 \cdot 2 + 20 \cdot 1 + 15 \cdot 1 + 6 \cdot 0 + 1 \cdot 1 = 89$$

$$F_{12} = 1 \cdot 5 + 7 \cdot 3 + 21 \cdot 2 + 35 \cdot 1 + 35 \cdot 1 + 21 \cdot 0 + 7 \cdot 1 + 1 \cdot (-1) = 144$$

$$F_{13} = 1 \cdot 5 + 8 \cdot 3 + 28 \cdot 2 + 56 \cdot 1 + 70 \cdot 1 + 56 \cdot 0 + 28 \cdot 1 + 8 \cdot (-1) + 1 \cdot 2 = 233$$

↑ By filling in, with  $n = 5$ , and summing up, we obtain our familiar Fibonacci series.

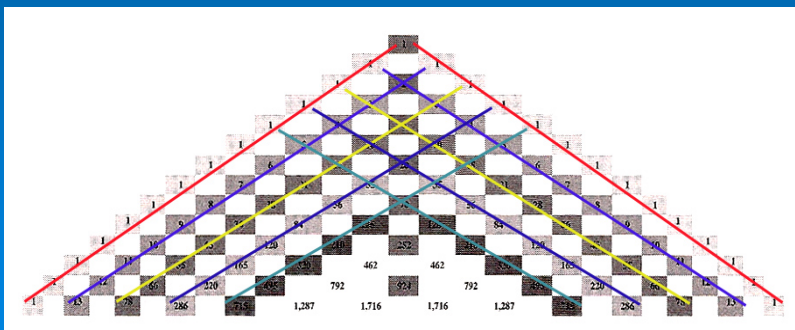

← An interesting pattern in Pascal's Triangle are the lists of shaped numbers showing up, just as it was taught in the ancient Pythagorean School.

The two red lines are the matrix boundary of "straight 1", while the blue lines are the sequence of natural numbers. Then we have:

• **Yellow lines:** the series of TRIANGULAR NUMBERS:

1 - 3 - 6 - 10 - 15 - 21 - 28 - 36 - 45 - 55 - 66 - 78 ...

• **Violet Lines:** the series of TETRAHEDRAL NUMBERS:

1 - 4 - 10 - 20 - 35 - 56 - 84 - 120 - 165 - 220 - 286 ...

• **Green lines:** the series of 4D PENTATOPE NUMBERS:

1 - 5 - 15 - 35 - 70 - 126 - 210 - 330 - 495 - 715 ...

# SG203.4.4.3 Pascal Triangle - Lucas Numbers (1)

In order to find the Lucas series in Pascal's Triangle, we need to modify the original Pascal's Triangle by replacing the "1s" on the right side by "2s". And then we carry the calculation of adding the two above numbers (like in the original Pascal's Triangle calculation). See the Pascal-Lucas Triangle →



	0	1	2	3	4	5	6	7	8	9	10	11	12	13	14	15	16	17	18	19	20	
0	2																					
1	1	2																				
2	1	3	2																			
3	1	4	5	2																		
4	1	5	9	7	2																	
5	1	6	14	16	9	2																
6	1	7	20	30	25	11	2															
7	1	8	27	50	55	36	13	2														
8	1	9	35	77	105	91	49	15	2													
9	1	10	44	112	182	196	140	64	17	2												
10	1	11	54	156	294	378	336	204	81	19	2											
11	1	12	65	210	450	672	714	540	285	100												
12	1	13	77	275	660	1122	1386	1254	825													
13	1	14	90	352	935	1782	2508	2640														
14	1	15	104	442	1287	2717	4290															
15	1	16	119	546	1729	4004																
16	1	17	135	665	2275																	
17	1	18	152	800																		
18	1	19	170																			
19	1	20																				
20	1																					
	2	1	3	4	7	11	18	29	47	76	123	200	322	521	843	1364	2207	3571	5778	9349	15127	

When left-justifying the Pascal-Lucas Triangle, the column sums give the the Lucas numbers series.

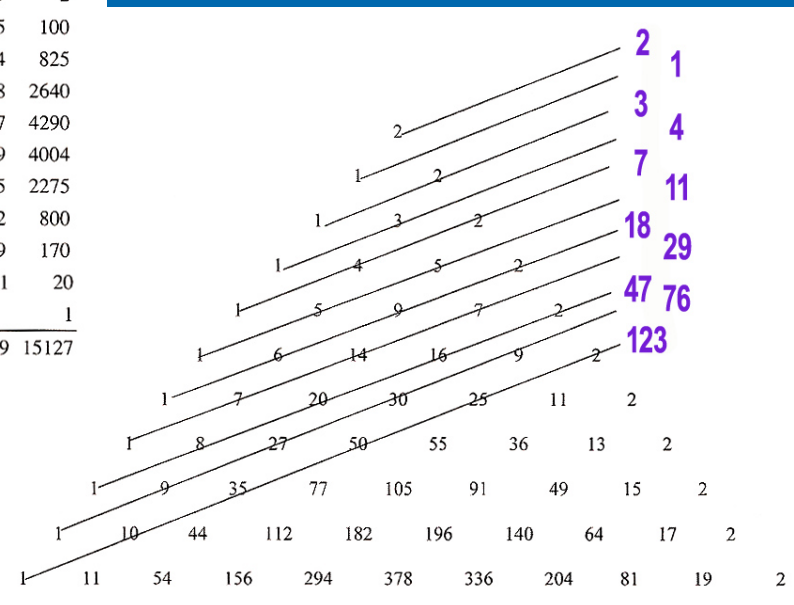

(Tables after Posamentier & Lehmann)

Summing up the numbers → in the shallow diagonals gives the Lucas numbers



## SG203.4.4.4 Pascal Triangle - Lucas Numbers (2)

Because the Fibonacci & Lucas series are so closely related, we can, just like we did for the Fibonacci numbers, represent the Lucas numbers in the arrangement of Pascal's Triangle. Here we have:  $L_0 = 2$ ,  $L_n = 1$  and the relation  $L_{n+1} = L_n + L_{n-1}$

↓ Representation of the Lucas numbers using the coefficients of Pascal's Triangle.

$$L_n = 1 \cdot L_n$$

$$L_{n+1} = 1 \cdot L_n + 1 \cdot L_{n-1}$$

$$L_{n+2} = 1 \cdot L_n + 2 \cdot L_{n-1} + 1 \cdot L_{n-2}$$

$$L_{n+3} = 1 \cdot L_n + 3 \cdot L_{n-1} + 3 \cdot L_{n-2} + 1 \cdot L_{n-3}$$

$$L_{n+4} = 1 \cdot L_n + 4 \cdot L_{n-1} + 6 \cdot L_{n-2} + 4 \cdot L_{n-3} + 1 \cdot L_{n-4}$$

$$L_{n+5} = 1 \cdot L_n + 5 \cdot L_{n-1} + 10 \cdot L_{n-2} + 10 \cdot L_{n-3} + 5 \cdot L_{n-4} + 1 \cdot L_{n-5}$$

$$L_{n+6} = 1 \cdot L_n + 6 \cdot L_{n-1} + 15 \cdot L_{n-2} + 20 \cdot L_{n-3} + 15 \cdot L_{n-4} + 6 \cdot L_{n-5} + 1 \cdot L_{n-6}$$

$$L_{n+7} = 1 \cdot L_n + 7 \cdot L_{n-1} + 21 \cdot L_{n-2} + 35 \cdot L_{n-3} + 35 \cdot L_{n-4} + 21 \cdot L_{n-5} + 7 \cdot L_{n-6} + 1 \cdot L_{n-7}$$

$$L_{n+8} = 1 \cdot L_n + 8 \cdot L_{n-1} + 28 \cdot L_{n-2} + 56 \cdot L_{n-3} + 70 \cdot L_{n-4} + 56 \cdot L_{n-5} + 28 \cdot L_{n-6} + 8 \cdot L_{n-7} + 1 \cdot L_{n-8}$$

$$L_1 = 1 \cdot 1 = 1$$

$$L_2 = 1 \cdot 1 + 1 \cdot 2 = 3$$

$$L_3 = 1 \cdot 1 + 2 \cdot 2 + 1 \cdot (-1) = 4$$

$$L_4 = 1 \cdot 1 + 3 \cdot 2 + 3 \cdot (-1) + 1 \cdot 3 = 7$$

$$L_5 = 1 \cdot 1 + 4 \cdot 2 + 6 \cdot (-1) + 4 \cdot 3 + 1 \cdot (-4) = 11$$

$$L_6 = 1 \cdot 1 + 5 \cdot 2 + 10 \cdot (-1) + 10 \cdot 3 + 5 \cdot (-4) + 1 \cdot 7 = 18$$

$$L_7 = 1 \cdot 1 + 6 \cdot 2 + 15 \cdot (-1) + 20 \cdot 3 + 15 \cdot (-4) + 6 \cdot 7 + 1 \cdot (-11) = 29$$

$$L_8 = 1 \cdot 1 + 7 \cdot 2 + 21 \cdot (-1) + 35 \cdot 3 + 35 \cdot (-4) + 21 \cdot 7 + 7 \cdot (-11) + 1 \cdot 18 = 47$$

$$L_9 = 1 \cdot 1 + 8 \cdot 2 + 28 \cdot (-1) + 56 \cdot 3 + 70 \cdot (-4) + 56 \cdot 7 + 28 \cdot (-11) + 8 \cdot 18 + 1 \cdot (-29) = 76$$

↑ By filling in, with  $n = 1$ , and summing up, we obtain our familiar Lucas series.

# SG203.4.5.1 Fibo in Technology (1) Scaling in Electronics

In engineering practice, resistor networks (for current & voltage division) are widely used. We give here 3 similar descriptions of their use, as related to the Fibonacci series.

- Petr Beckmann, in his book *"A History of Pi"* (1971) gives an example of an ancient Egyptian method of calculation that is still used today for figuring out currents in electronic circuits. The *Ahmes papyrus* (about 1650 BCE and copied from earlier works) uses a method called *"regula falsi"* (rule of the mistake) i.e. assuming a probably wrong solution and then correcting it proportionally. A 20th century version of the *regula falsi*, called scaling, is illustrated below.

*"The calculation of the currents due to a known voltage V in the network above becomes very cumbersome when the circuit is worked from left to right. So one assumes a (probably wrong) current of 1 ampere in the last branch and works the circuit from right to left, which is much easier. This ends up with the wrong voltage, which is then corrected and all the currents are scaled in proportion."*

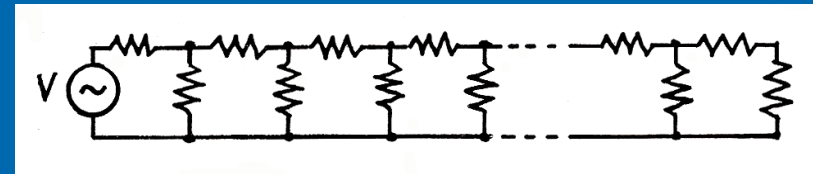

Beckmann also notes that if all the elements of the circuit are 1 ohm resistors, and the current in the last branch is 1 ampere, then the voltage across the resistors (from right to left) are Fibonacci numbers: 1, 1, 2, 3, 5, 8, 13, 21, 34, 55...

- The following "Fibonacci" resistance ladder was found in Midhat J. Gazalé's book *Gnomon, From Pharaohs to Fractals* (1999).

Gazalé explains: *"In this iterative network, all resistances are 1 ohm, and they are numbered 1, 2, 3... The input impedance is  $Z_0$  ohms (see figure with Fibonacci fraction). When the number of resistances is sufficiently large, the ladder's input impedance is seen to approach 1.618 ohms."*

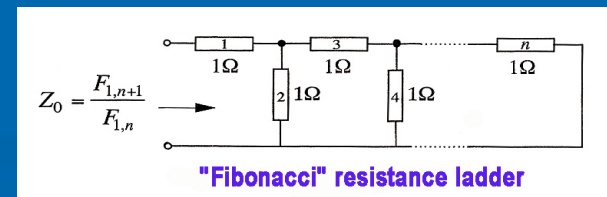

- In his *Mathematics of Harmony* (2009), A. Stakhov describes the "Golden Resistor Divider". *"By taking the values of the resistors to be the golden p-proportion (p = 1, 2, 3, 4...), we can calculate the coefficient of voltage transmission between the adjacent "connecting points" of the Golden Divider as equal to the reciprocal of the golden p-proportion."* Stakhov adds that this could lead to the development of digital-to-analog converters.

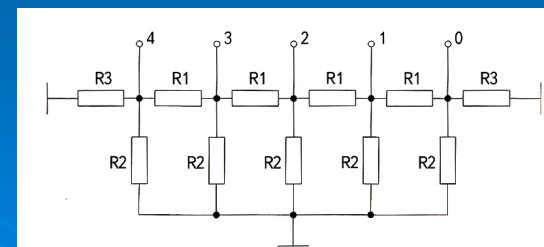

↑ Golden Resistor Divider

# SG203.4.5.2 Fibos in Technology (1) Fibonacci Computers

In 1939, Dutch doctor Edouard Zeckendorf proved that each positive integer can be represented as the unique sum of non-adjacent Fibonacci numbers. Zeckendorf's theorem states that every positive integer can be represented in a unique way as the sum of one or more distinct Fibonacci numbers in such a way that the sum does not include any two consecutive Fibonacci numbers. Such a sum is called the *Zeckendorf representation* of N.

Examples:

$$38 = 34 + 3 + 1 \quad 39 = 34 + 5 \quad 40 = 34 + 5 + 1 \quad 41 = 34 + 5 + 2$$

$$100 = 89 + 8 + 3$$

Note that there are other ways of representing 100 as the sum of Fibonacci numbers:

$$100 = 89 + 8 + 2 + 1 \quad \text{and} \quad 100 = 55 + 34 + 8 + 3$$

but these are not *Zeckendorf representations* because 1 and 2 are consecutive Fibonacci numbers, as are 34 and 55.

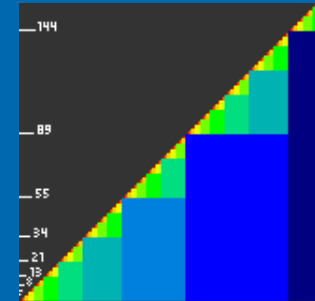

## Fibonacci Coding

*"The Fibonacci code is closely related to the Zeckendorf representation. Fibonacci coding is a universal code which encodes positive integers into binary code words. All tokens end with "11" and have no "11" before the end.*

*Fibonacci coding has a useful property that sometimes makes it attractive in comparison to other universal codes: it is an example of a self-synchronizing code, making it easier to recover data from a damaged stream. With most other universal codes, if a single bit is altered, none of the data that comes after it will be correctly read. With Fibonacci coding, on the other hand, a changed bit may cause one token to be read as two, or cause two tokens to be read incorrectly as one, but reading a "0" from the stream will stop the errors from propagating further. Since the only stream that has no "0" in it is a stream of "11" tokens, the total edit distance between a stream damaged by a single bit error and the original stream is at most three."*

(Wikipedia)

Symbol	Fibonacci representation	Fibonacci code	
1	$F(2)$	1	11
2	$F(3)$	2	011
3	$F(4)$	4	0011
4	$F(2) + F(4)$	5	1011
5	$F(5)$	8	00011
6	$F(2) + F(5)$	9	10011
7	$F(3) + F(5)$	10	01011
8	$F(6)$	16	000011

## Stakhov and the Fibonacci Computers

In the 1970s, Ukrainian mathematician of Harmony A. Stakhov developed the Zeckendorf concept into a new positional method of number representation (*Fibonacci p-codes*), a new *Fibonacci Arithmetic* (allowing error detection) and new *Fibonacci Computers*.

From 1977 to 1995, A. Stakhov organized the engineering projects on Fibonacci Computers (Vinnitsa Polytechnic Institute, Ukraine). 65 foreign patents for inventions in the field of Fibonacci computers were issued by patent offices in the US, Japan, England, France, Germany etc...

Fibonacci codes have found recent applications in digital signal processing: the realization of super-fast algorithms requires a processing of numerical data represented in the Fibonacci p-codes, as well as specialized Fibonacci signal processors.

## SG203.4.6.1 Fibo in Nature (1) Optics

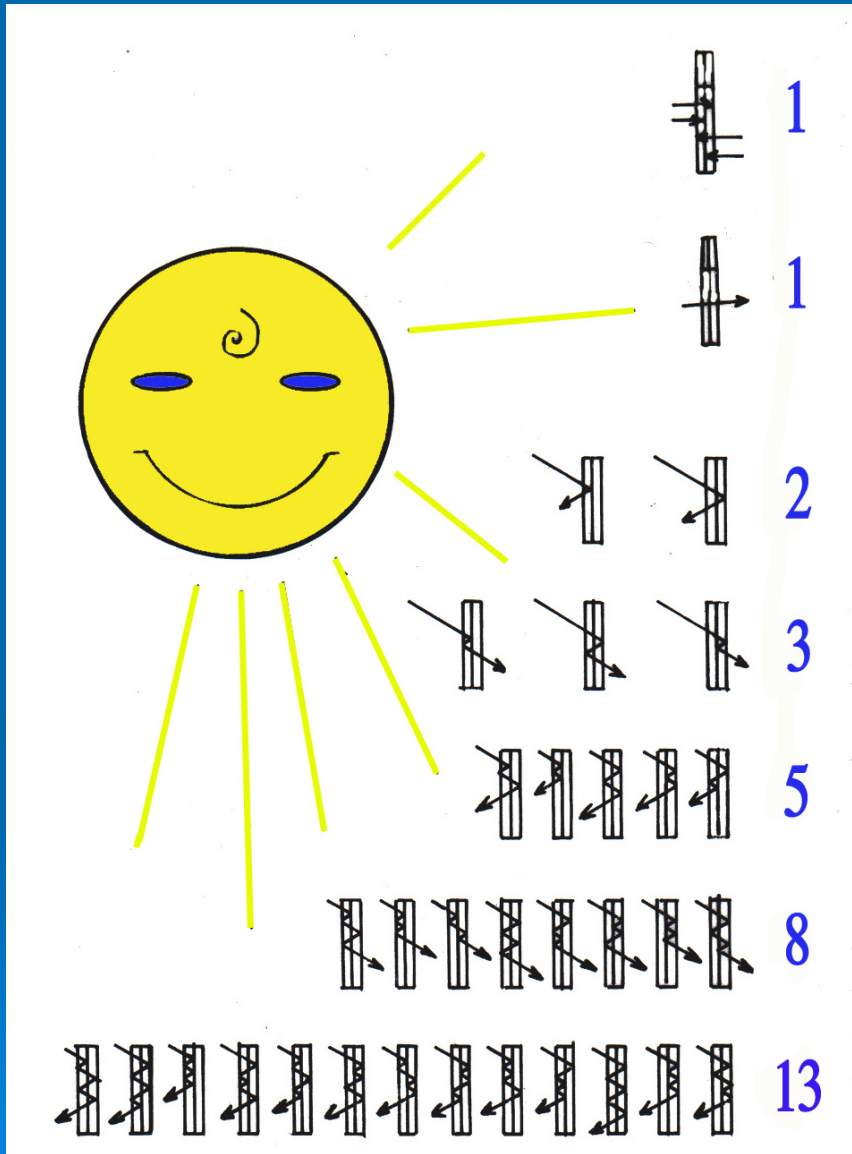

Take two glass plates with different light refraction properties ("indices of refraction"), i.e. made out of different types of glass. Mount them face to face.

Now, if a beam of light is incident upon the two plates, part of the light will be transmitted, part absorbed and the rest reflected. There will be multiple reflections allowed and accounted for by the physics of light rays (optics). The number of different paths followed within the glass plates before the rays emerge depends on the number of reflections which the ray undergoes.

It so happens that  
the number of paths  
followed by light rays  
through two glass plates  
is a  
**Fibonacci Number:**  
**1 - 1 - 2 - 3 - 5 - 8 - 13**

(Sources: Mario Livio. *The Golden Ratio*. 2002  
Huntley. *The Divine Proportion*. 1970)



## SG203.4.6.2 Fibon in Nature (2) Atoms

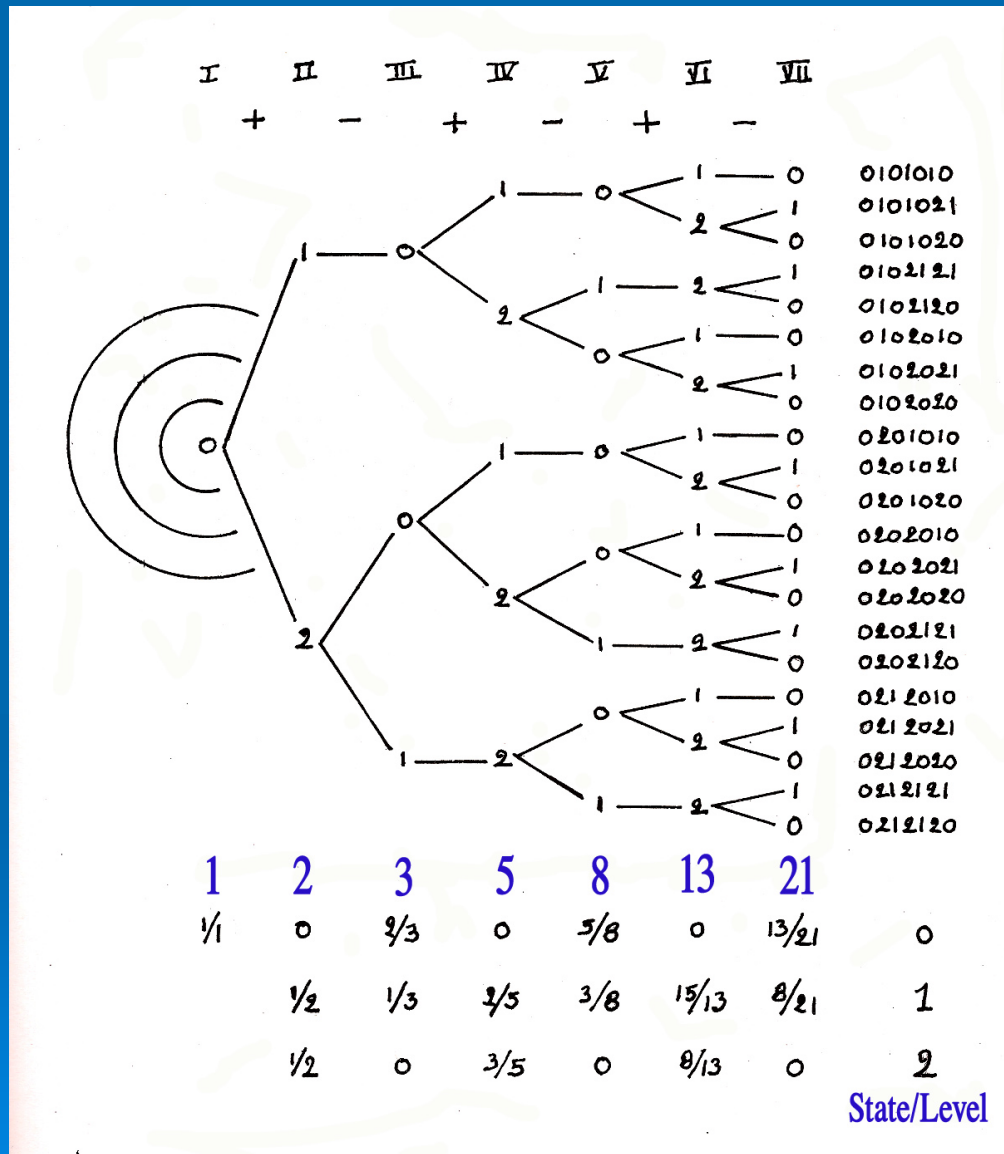

### Possible Histories of an electron of Hydrogen Gas

Fibonacci Numbers show up in connection with the possible histories of an electron in an atom of hydrogen gas.

Electrons pass through 3 different states depending on their energy levels (state 0, state 1 and state 2) and certain rules apply as they gain or lose energy (+ or -).

← The diagram shows the successive fractions, formed of Fibonacci numbers, of the total number of atoms found in each state as time passes.

The numbers of possible different histories of an electron are Fibonacci numbers.

(Source: H. E. Huntley.  
*The Divine Proportion*, 1970)

## SG203.4.6.3 Fibo in Nature (3) Plants

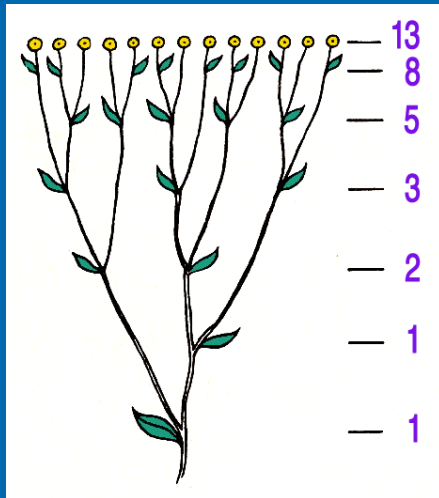

↑ Sneezewort  
*Achillea ptarmica*

For more on Phyllotaxis  
◆ SG205

Phyllotaxis (the study of leaves, petals, seeds arrangement in plants) has come a long way since the word was coined in 1754 by Swiss naturalist Charles Bonnet and the phenomenon was first described by Leonardo da Vinci and Johannes Kepler.

Now a well established discipline in mathematical biology and system morphogenesis, phyllotaxis provides a wealth of data on the Phi-based Growth Angle and the prevalence of the Fibonacci series in plant patterns.

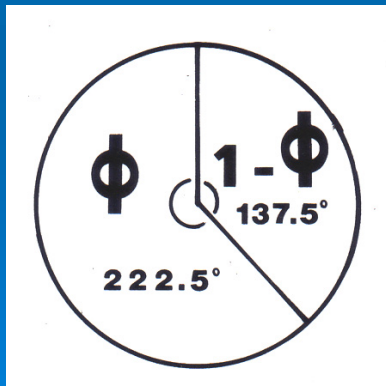

↑ The Growth Angle in plants is a function of Phi

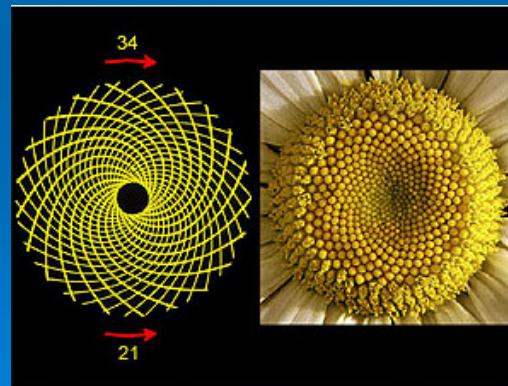

↑ Daisy with a 21 / 34 ratio

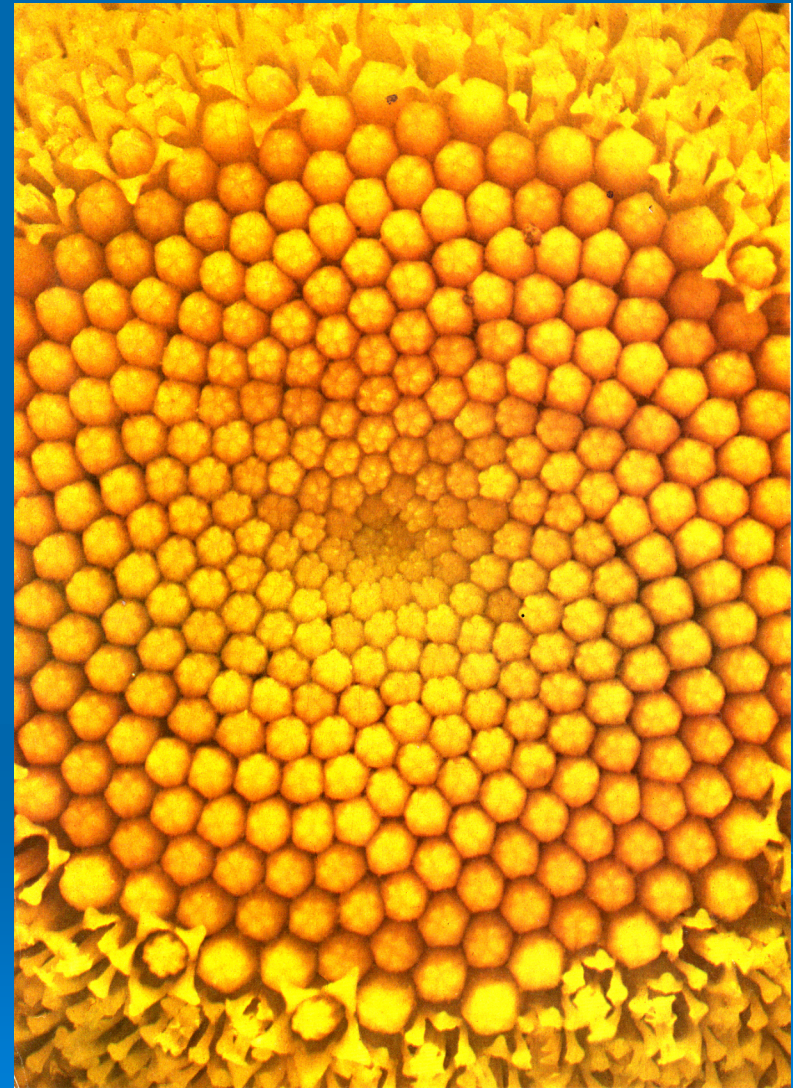

↑ Sunflower displaying 21 turns clockwise and 34 turns counterclockwise.

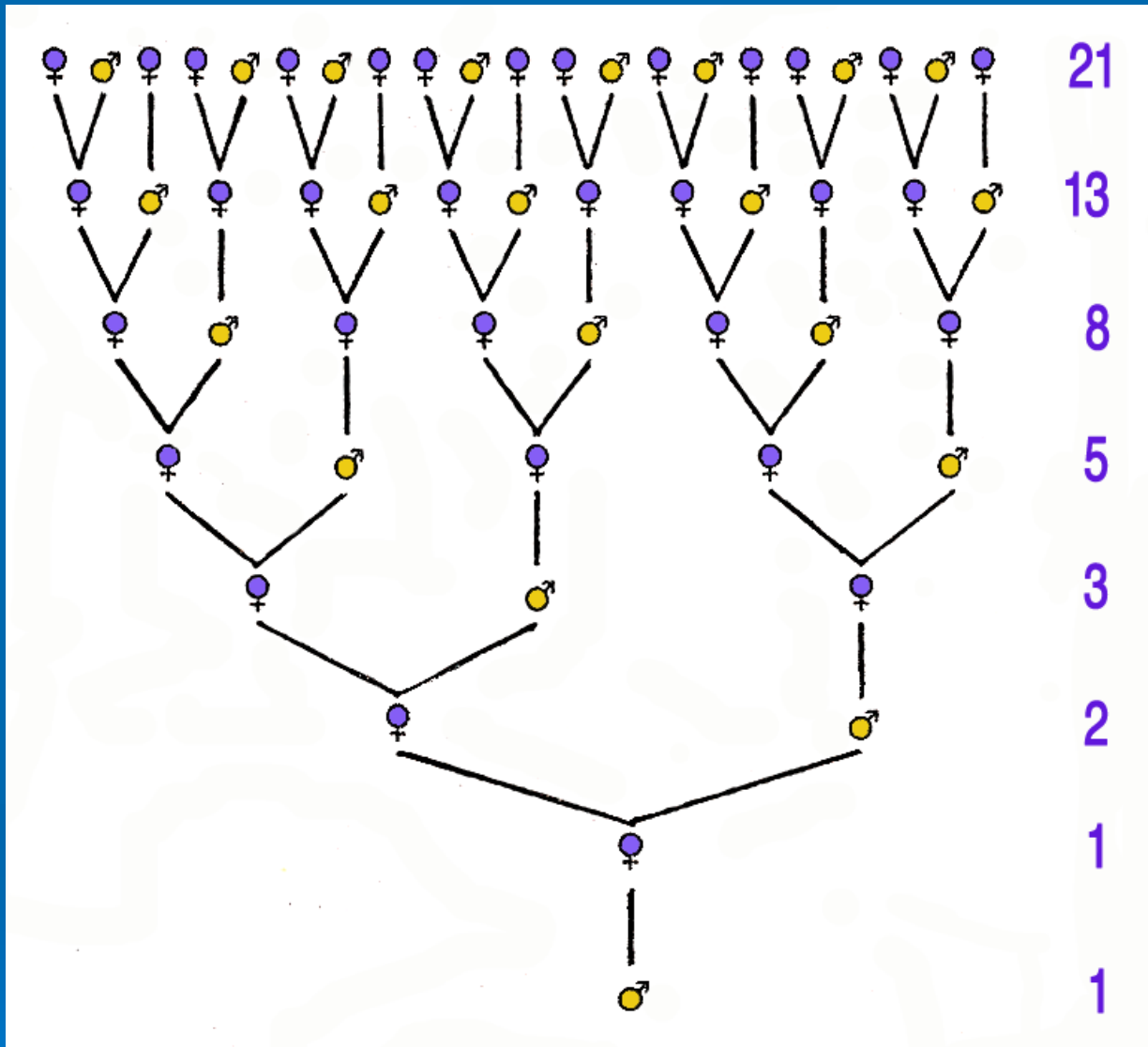

## SG203.4.6.4 Fibo in Nature (4) Drone Bees

The Queen's eggs are fertilized by drones and develop into females (queens or workers). So, female bees have two parents: a mother and a father. On the other hand, a male bee ("drone") comes from the unfertilized egg of worker bees. So a drone has no "father" and only a "mother".

The family tree of a drone will then exhibit: 1 parent in the first line (its mother), 2 grandparents (its mother's parents) in the second line, 3 great-grandparents (2 parents of its grandmother + 1 of its grandfather) in the third line, 5 great-great-grandparents etc...

**The family tree of a drone bee.**

Note that each line of Fibonacci numbers is made out of the two lower Fibonacci numbers:

Example: top line of total = 21 of which 8 males and 13 females.

You see the  
number pattern:  
Fibonacci



## SG203.4.6.5 Fibo/Lucas in Nature (5) DNA

In his seminal 1997 book *L'ADN Decrypté* (DNA Decoded), mathematician and computer scientist Jean-Claude Perez methodically explains how he uncovered a revolutionary fact: the DNA is woven with a Supra-Code of multi-layered resonances that constitute a hidden yet precise language.

The sequences of the four DNA bases ACTG are harmonically interconnected through properties based upon the Fibonacci & Lucas Series, and therefore the Golden Ratio. J. C. Perez calls these properties “Resonances” and their global patterns of music-like pulses the “DNA Supra-Code”.

This is BIG NEWS! And yet this discovery has not yet penetrated the walls of official genetics, even though it was made in 1990 and regularly published since 1991.

When finally accepted, it will herald the entry of Sacred Geometry in genetics and will open a new, deeper level of perception of their field for geneticists and biologists.

And, like always when the “time comes” for updating obsolete scientific models, it will suddenly seem natural and obvious: YES, of course, the DNA is a harmonic and musical score, a grand orchestration of life with exquisite chords in tune with PHI Major and Phi Minor. The two Leonardos would have been thrilled.

*In later modules [◆SG204], we will go into a lot more details about the protocols of research and the implications of this revolutionary discovery.*





## SG203.4.7 Reflections on Fibonacci/Lucas in Science

From this brief survey, we can get a glimpse of how the Fibonacci Series is an ordering pattern of fractal harmony and efficient distribution in space-time. We are barely peeling off the first layers of appearances in the 3D realm and we are already uncovering the extensive presence of the Fibonacci lattice structure. Soon new comprehensive explanations will provide a larger understanding, possibly related to the Zero Point Vacuum Field.

The Fibonacci Series and its limiting convergence to PHI is only the visible expression of a much more complex and universal dynamics of cascading harmonic organization of the cosmos. These are exciting times, on the cusp of two paradigms. Could it be that they be related by a Fibonacci number in terms of their expansion factor? There is evidence that consciousness itself might follow quantum, fractal steps of evolutionary expansion and move along a spiral pattern that could well be the PHI Proportion...

To be sure, the Fibonacci patterns in nature were established way before Leonardo da Pisa aka Fibonacci was born or the Fibonacci Association was created in 1963. Yet it is interesting to note that human perception seems to only be progressively attuned to the natural harmonic order represented by the Fibonacci Series. It is as if human consciousness, as it evolves & expands, is becoming more able to consciously look through the superficial randomness and suddenly SEE underlying patterns of order never perceived before. As an example: older herbal books present drawings of the *Sunflower* along with some of its medicinal properties, but if you look closely at the drawings, the center of the sunflower is a collection of circular rings with random points, completely missing the Fibonacci-based exact number of spirals of the florets (seeds) that are now so obvious to us.

My conclusion is that we are just WAKING UP to perceive the entire universe as a gigantic HARMONIC ORCHESTRATION of wave forms, all inter-connected in multi-simultaneous ways: a grand play indeed to be born into. The journey of cosmic consciousness has begun: welcome!



← Copperplate engraving of a sunflower (*Helianthus Annuus*) from *Hortus Floridus* by Crispian van de Passe. Published in Arnheim in 1614-1617.

(From Richard G. Hatton. Handbook of Plant and Floral Ornament from Early Herbals. Dover. 1960)

The way → most people see sunflowers.

But oftentimes, the spirals had to be pointed out before the person suddenly SAW them.

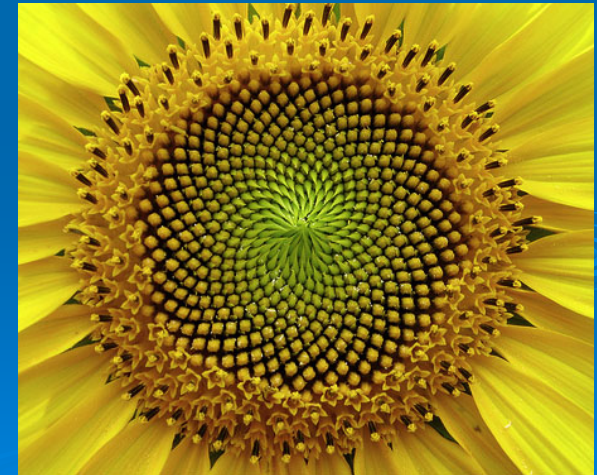

## SG203.5 Chapter 5. Vortex Science



Chapter 5 is a promenade through the science, the beauty and the sacred geometry of the Vortex as the key dynamics of nature.

We are introducing here some unorthodox naturalists & scientists, starting with the masterful insights of Viktor Schauberger into the workings of nature and the concept of *Implosion*. Walter Russell and Lawrence Edwards also had a lot to say about the universal vortex. More recently, Dan Winter has focused on the Golden Spiral as the waveguide to the Golden Vortex. And current research has uncovered polygonal vortices.

Along the vortex way, we will present various bio-mimicry applications and technologies heralding our growing awareness of eco-green sustainability.



## SG203.5.1.1 The Insights of Viktor Schauberger (1)

Viktor Schauberger (1885 - 1958) was an Austrian forester/forest warden, naturalist, "Gaia" philosopher, inventor and bio-mimicry pioneer. Coming from a 1000 years lineage of foresters and having chosen to continue the family's tradition, Viktor Schauberger was well placed to observe nature with a keen eye. As a witness, in remote Austrian forests, to extraordinary occurrences (see next page), Viktor Schauberger was able to understand firsthand certain powers of nature that were beyond the accepted laws of science & technology.

Schauberger's longstanding observations of nature led him to formulate new concepts about the workings of nature based on the dynamics of the vortex and the principle of IMPLOSION. Pioneering what is nowadays called "Eco-Technology", Schauberger developed a new science of fluidic vortices, dynamic motion in nature and levitational effects. He built implosion propulsion systems for spacecrafts, devised vortex turbines, self-cleaning pipes and water regeneration vortical systems capable of re-creating live water.

Schauberger's credo was that *"we must learn from Nature rather than try to correct Her"*. His goal was to liberate humanity from increasing dependence on inefficient, polluting and centralized systems of energy generation. Fifty years later, his insights are starting to be understood and applied.

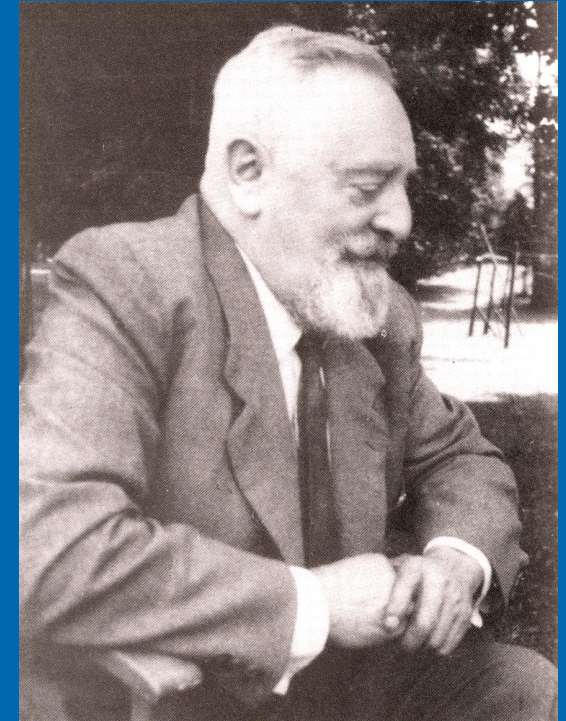

*"The Upholder of the cycles which support the whole of life is WATER."* V. Schauberger.

*"Of particular concern to Viktor Schauberger was the way in which rivers were being regulated and water handled in total ignorance of Nature's laws. Forcing water to move in concrete trapezoid canals, in cylindrical steel pipes etc... had the same effect as enshrouding a human being in a straightjacket, which makes it aggressive (effect of over-warming on the oxygen content), takes away its character, its freedom and robs it of all its energy. Under such conditions, water can no longer remain benign and disease-free, but becomes violent and disease-promoting".*  
(Callum Coats. *Living Energies*.)

← The stark contrast between the meandering pattern of flow in a natural river, a continually varying system (far left), and a mechanically-engineered watercourse (left). [◆SG205 for the fractal geometry of rivers]. The artificial "irrigation" canal, with no variation in width or radius bend, and no trees or shade, is a sterile contrivance that delivers no healthy, vital water to the point of use. It shows that the designers were totally oblivious to the fact that water is an essential living substance and concerned themselves solely with the cheapest, "efficient" way of transporting a supposedly "inert" liquid.



## SG203.5.1.2 The Insights of Viktor Schauberg (2)

Schauberger's dream and service to humanity is to keep possible  
the most simple and most fulfilling human gesture:  
*drinking pure, LIVE water* activated by the vortical streaming of a natural flow  
drawing from the Earth, the Sun and the Cosmos the most nutritive life force qualities.



← Giovanni  
Segantini

*Bünderin Am  
Brunnen*  
1887.



## SG203.5.1.3 The Insights of Viktor Schaubberger (3)

Viktor Schaubberger has described some of the revelations he experienced about vortex motion in nature, and specially the liquid vortex. The following stories are quoted from *Nature as Teacher* (1998), volume #2 of the Eco-Technology series of the Schaubberger papers, as collected by Callum Coats.

**The Vortex Dance of the Eagle and the Fish.** *"Punctual almost to the minute, the mighty fish-eagle made its appearance and flew over the salmon holes just above the water, emitting a shrill cry and flapping its wings particularly vigorously... The eagle then rose almost vertically in smaller and smaller spiraling circles, altering its course with an occasional flap of the wings... All the salmon were copying the upward spiraling, swirling movements of the eagle above them. As though joined together with a string, they followed each other towards the surface, describing narrower and narrower spiral turns in their circular ascent... Then, like a block of stone, with wings furled and talons tight against its body, the eagle plummeted down onto one of the salmon holes. Just above the water surface, it braked its fall with a flap of the wings and a large salmon was already wriggling in its claws."*



[www.whiteriver.net](http://www.whiteriver.net)

**The Levitating Trout.** *"It was during the spawning season on a bright moonlit winter night (as) I was sitting near a waterfall... Every movement of the numerous fish could be discerned in the crystal-clear water. Suddenly, the fish scattered in all directions. The reason for their flight was the appearance of a particularly large trout which came up from below, made for the base of the waterfall and immediately began to swim around it. These movements described the shape of an egg and seemed as though the trout was rocking itself to and fro in strongly pronounced looping movements. It was dancing a sort of reel in the swirling water. All at once it disappeared under the fall of water, which fell like liquid metal into the pond. The trout suddenly stood up on its tail and in the conically converging stream of water I perceived a wild movement like a spinning top. Having temporarily disappeared, the trout then re-emerged from this spinning movement and floated motionlessly upwards. Upon reaching the underside of the topmost curve of the waterfall it did a quick somersault in a high curve upstream and with a loud smack was thrown beyond the upper curvature. With a powerful flick of its tail-fins it disappeared."*

**Dancing Logs & Stones.** *"The water (in the mountain stream) was several meters deep, crystal-clear and totally still... I noticed that lumber logs were performing a remarkable dance. It was as though the logs lying in the absolutely clear water had become magnetic. Now and then the butt of one log lifted, floated upwards slightly, laying itself a few feet over another log, only to recoil in the opposite direction the very next moment almost as if in fright... Gradually evening fell and with it a even keener chill. Suddenly a heavy log stood straight up, paused for a moment, and with a lurch shot out of the water, to be encircled immediately with a ruff of ice. Soon other logs began to perform the same witches' dance. For a few minutes several logs swayed to and fro in the water as if alive..."*

*There! There was a strange activity among the variously-sized stones lying on the bed. A few were as large as a human head and began to come to life. Flouting all the laws of gravity, they drifted about, attracting and repelling each other... All of a sudden, a large, head-sized stone began to gyrate slowly in circles like the trout at the waterfall before it began to float upwards. It was egg-shaped... The very next moment the stone was at the surface, gently rocking just like the logs had done. Soon a second, then a third, and still more stones, all making the same maneuvers, rose to the surface of the water.*

*Eventually all the smooth and rounded stones rose to the surface. The remaining rough, angular stones were left motionless on the bed of the stream."*

# SG203.5.2.1 Implosion (1) Definition

In the course of his intensive studies of water flows, Schauberger used the term *implosion* to describe the suctional process that causes matter to move inwards (by centripetence), not outwards (by centrifuge) as is the case with explosion. This inward (centripetal) motion, however, does not follow a straight (radial) path to the centre: it follows a spiraling, whirling path. This is called a *vortex*, an increasingly centripetal dynamics of fractality.

While **IMPLOSION** is new to current scientific thinking, it is actually as primordial and ancient as the universe.



↑ Explosion (top) is centrifugal  
Implosion (bottom) is centripetal

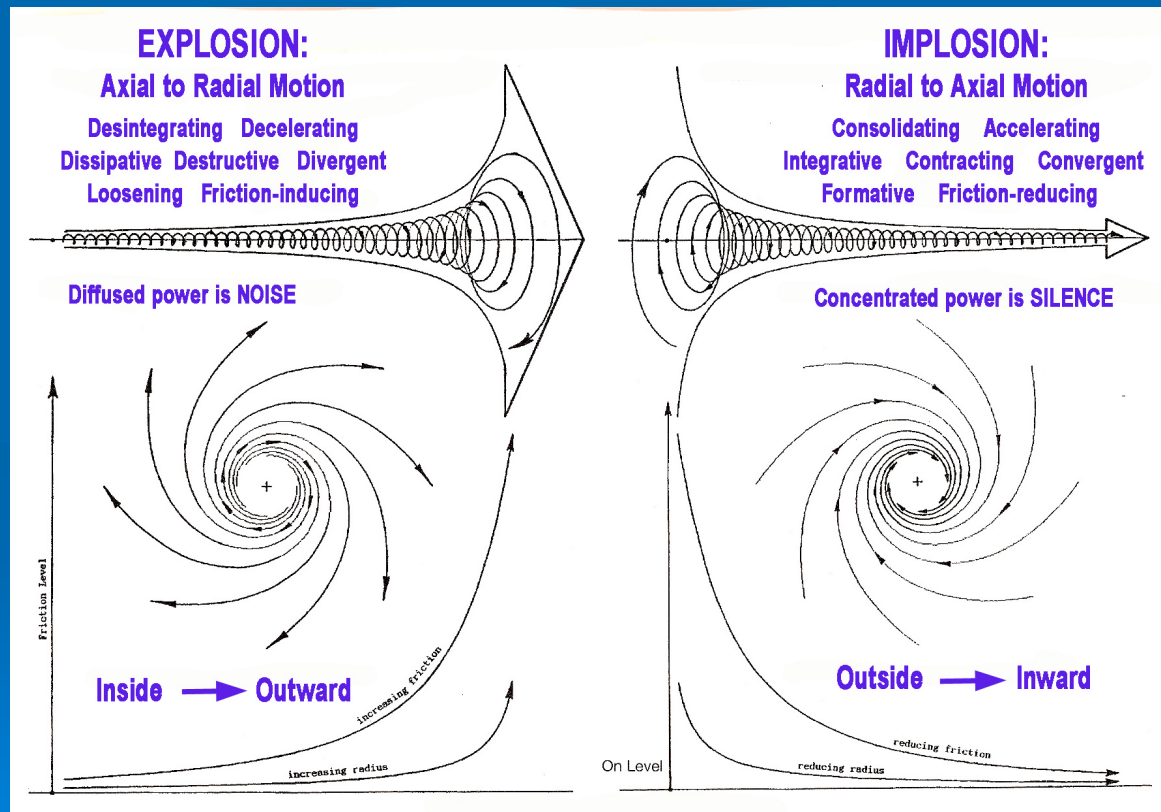

↑ Centrifugal (left) and centripetal (right) motion.  
Callum Coats. *Living Energies*.

Implosion can be described as the creative process on the other side of *entropy*. Classical physics insists that entropy, per the "Second Law of Thermodynamics", is the only dynamics in nature. Entropy is "a measure of the disorganization or degeneration of a system". As a result, current technology uses explosive, entropic-degenerative processes to create power.

Seeing entropy only is being half-blind: "the apple has to be up the tree before it falls", plants grow against gravity, galaxies are born... Prior to entropy, there is a "negentropic", generative, creative dynamics in the universe. The term "negative entropy" was introduced by Erwin Schrödinger in 1943 and is now replaced by *syntropy* (*implosion*), a more positive term.

**Implosion is the process of the generative dynamics at play in the universe.**

EXPLOSION	IMPLOSION
Expansion / Dilation	Impansion / Concentration
Repulsion / Resistance	Suction / Harmonic Attraction
Centrifugence /-fugal	Centripetence /-petal
Excentric / Extroversion	Concentric / Introversion
Entropic Decay / Energy Loss	Syntropic Generation / Energy Gain
Gravitation / Gravity	Levitation / Levity
Fire Technologies / YANG principle	Water - Air - Earth Technologies / YIN principle
Heat by Friction	Cold by Fusion
Nuclear Hot Power	Vortical Cool Power
Physical Energy / Atomic Fission	Etheric Energy / Zero-Point
Square / Circle Shapes	Spiral / Fractal Shapes
Euclidian Geometry	Phi Vortex Geometry
Materium	Vacuum
Bio-electricity	Bio-magnetism

## SG203.5.2.2 Implosion (2) Spiral Fractality

*"Through the interaction between centrifugal & centripetal forces functioning on a common axis, Viktor Schauberger was able to implosively produce a powerful biological vacuum and to return the physical matter (water or air) into its primary energetic matrix - a higher dimensional state."  
(Callum Coats. Living Energies)*

← Two approaches and two choices for the science & technology of "energy". Implosion is an aspect of a deeper and more harmonious understanding of the universe based on its life generating principle. This is still unaccepted by established science but is ineluctable.

### Science and the Shaming of Cold Fusion

Cold Fusion is the nuclear fusion of atoms at conditions close to room temperature.

Ever since the 1989 announcement by Pons & Fleishmann of producing anomalous or "excess heat", cold fusion has been ridiculed by the establishment science and an insidious campaign of shaming its proponents and researchers was successfully implemented. No funding is possible in the US. This is partly because cold fusion research raises very interesting but "taboo" questions relating to the *higher-dimensional aspects of the universe* in general and the production of *zero-point energy* in particular.

It goes as far as the US Patent Office refusing patents on cold fusion devices on the grounds that they are akin to "perpetual motion machines".

Also, a new paradigm of "quantum observation" and "creative physics" has to be applied to this kind of exploration on a new frontier - and this is challenging to mainstream scientists: it is easier & safer to join the howling crowd.

However, renamed *Low Energy Nuclear Research (LENR)* and more recently *Condensed Matter Nuclear Science (CMNS)*, "cold fusion" is quietly investigated around the world. An international conference on the subject has regularly been held since 1990.

*"We must think an octave higher."*

Viktor Schauberger

## SG203.5.2.3 Implosion (3) Rethinking Technology

The observation of nature's processes based on vortical motion and the new concept of implosion oblige us to access a larger understanding of how the universe functions. As pointed to by an increasing number of thinkers, scientists and visionaries, a New Paradigm science is dawning. It is larger because it is bridging over to wisdom as it is involving us, as agents of conscious awareness. In the next & final chapter of SG203-B, we will review this upcoming "grade" of science revealing itself at the cutting edge of human evolution.

Meanwhile, on the practical level of global survival, we have to entirely re-think the technologies we have been developing since over a century. Patching up the disasters and implementing a few environmental measures is plainly pitiful & criminal re: humanity. We need to see very big and to start from an entirely different foundation: we need to work WITH rather than AGAINST nature in order to invent and apply real solutions to today's challenges of power & energy generation.

Because of the vested interests of elitist power groups, current technology is based on EXPLOSION, that is the process of extracting the coal, gas and oil resources stored, during evolutionary eons, in the womb of Mother Earth and exploding them in order to produce the power to heat/cool our homes, drive our cars, trucks & planes and run our appliances and industrial parks. In addition, exploding the atom has been developed and presented as a viable alternative, regardless of the extraordinary dangers of radiation and misuses for warfare. Let us face it: explosion has been the foundation of our modern "civilization" and "happy modern living".

However, this is not working any more! As we have painfully become aware of, the EXPLOSIVE PROCESS IS PRIMITIVE: not only it is extremely wasteful and inefficient but is it totally un-sustainable, even in the most short-sighted term. The process of explosion, however useful it may seem to our arrogant ways, is an insult to any responsible management of the planet. Most of the chemical energy stored in fuel is lost in the conversion process into mechanical or electrical energy. *"To travel a distance of 1000 km (~600 miles) in an average car requires an energy expenditure of 1000 kW. This equals the energy requirement of one human being to live and do all his physical and intellectual activities for one year."* (Callum Coats, *Living Energies*.)

Most of the energy produced by the explosive use of fossil or nuclear fuels is lost through frictional resistance, which creates useless or harmful waste heat. In nature, unlike explosion technologies, minute temperature differences will cause very large changes. Cold fusion and biological transmutations happen with slight changes of the temperature gradients. The earth's elements (the waters, the lands, the atmospheric currents...) respond to equally small fluctuations in temperature. Same for the human body: when our temperature increases by half a degree above normal, we stop feeling good... Moreover, combustion by explosion of fuels generates polluting by-products and depletes the overall oxygen, thus making the entire web of life unwell. Explosive technologies are clearly a dilapidation of our human family inheritance and a blatant insult to future generations.

On an historical level, the phase of explosive technology is equivalent to the teen-age period of a human being and its blind urge to dilapidate the family's inheritance for mere self-gratification. As a life-style and level of awareness, explosion is an externally oriented focus favoring sudden outbursts (rather than inner processing) and a predator-type behavior looking externally for desirable sources of energy and grabbing them, by force if necessary: it leads to a corrosion of ethical and spiritual values as the well of inner energy has been covered & disavowed.

By harmonious contrast and evolutionary balance, technologies of IMPLOSION, as glimpsed in this chapter, are the next phase of human civilization. These nascent technologies of creative bio-mimicry are increasingly revealed by the growing global awareness of cooperation with nature, sustainability within larger systems in space & time, all-inclusivity of life and consciousness, perception of higher-dimensional formative forces, rediscovery of the wisdom built into traditional ways, new scientific breakthroughs in the fractal order of the universe... and just plain human common sense. Implosion technologies are premised on HARMONY & right proportion.

Water is the new teacher. Water is showing us how to follow the path of least resistance, how to seek and enter vortices, how to reduce conflict by implosively curving more and more inwards (the CURVE of hyperbolic geometries) and refraining from the gut-based controlling power of aggressive, straight shooting motion (the LINE of Euclidian coordinates). We are moving from an instinctual technology & science of rowdy boys to the co-creative wisdom of more mature citizens of the cosmos.



## SG203.5.2.3 Implosion (4) Vortex Perception

In *The Energy Evolution* (volume #4 of the Eco-Technology series of Schauberger writings), editor Callum Coats calls for "an inversion of all that has hitherto been held to be true scientifically and technologically". In other words, we are facing the urgency of completely redirect our creative perception. The western cultures are invited to evolve out of the STRAIGHT LINES & VOLUMES of an exclusive "Euclidian Perception" and rediscover the benefits of the CURVATURES, SPIRALITIES & SINUOSITIES ubiquitous in nature. For as much as that "chaos" was frightening to the well-organized western science, it is finally understood as a higher order of harmony and embedded energy.

Remember the two archetypal cosmic polarities in the universe: the line and the curve, expressed as the radial path and the spiral path or as the straight-edge and the compass? [◆SG101] And how the new symbol for the Golden Ratio PHI ( $\Phi$ ) perfectly embodies the harmonic balance between these two principles? [◆SG104]. The Golden Ratio is a spiraling, vortexing, fractal recursive and most efficient way to turn "chaos" into harmony.

Our science & technology are invited to come "around" in order to understand & apply the organic principles of the spiral power inherent in the "liquid vortex". As a precondition, our thinking and psychology are learning to graduate out of our obsessive habit with linear thinking which is imprisoning us in box-like architectures, life-styles, concepts and the technological generation of energies in discordance with nature's laws. As put by Callum Coats: "*The rational mind began to cut out important factors that were deemed extraneous, so as to achieve the most economically effective outcomes. Thus, for instance, the bends in rivers were truncated and the gradient steepened in order to 'improve' Nature's patterns of flow, without any account being taken of their contribution to the health and stability of the river. The result - violent discharges and inundations.*"

Let us welcome again the vortex perception of CURVILINEAR geometries in our environments, the fractal, implosive, centripetal energy processes, and their corresponding levels of consciousness expressing the intuitive wisdom from within. Then we will be able to attune ourselves to nature's processes and easily use the power of subtle energy sources.

Callum Coats explains further: "*(Vortex) energies and forms have the capacity not only to rehabilitate, enhance and stabilize nature's processes, but also our own (human process). As cooling, revitalizing energies, their widespread use would contribute much to the re-establishment of climatic equilibrium... Whereas in earlier days the technology to manufacture and mass-produce such vortex-based devices was not available, today this is no longer the case: computer controlled machines can produce forms of virtually any curvilinear complexity.*"

Vortex perception is based upon a harmonic systems vision, a more inclusive vision of the parts fractally embedded into the whole, and a deep experiential certitude of the self-similar inter-connectedness of the universe, from matter to consciousness. The traditional teachings of Sacred Geometry are preparing people to shift to this evolutionary level of integral survival: they teach how to integrate larger & larger dimensions of consciousness and how to add more & more harmonic octaves to our keyboard of conscious perception, thus enabling us to develop our potential as spirit flowers.

### Vortices in Brain Activity

*"The ECoG (electro-corticogram) reveals a conic phase gradient that accompanies an AM (amplitude modulation) pattern. The phase cone manifests a vortex, which is initiated by the null spike, and which is inferred to help stabilize and prolong its accompanying AM pattern that might otherwise be rapidly degraded by the turbulent neural noise from which it emerges."* (From an abstract by Walter J Freeman, UCLA (IEEE Neural Networks) [//citeseerx.ist.psu.edu](https://citeseerx.ist.psu.edu))

# SG203.5.3.1 Theodor Schwenk & George Adams (1)

Another actor in the re-emergence of the Vortex science & knowledge is Theodor Schwenk (1910-1986), a pioneer "chaos scientist". In the middle of the last century, Theodor Schwenk, a hydro-engineer, started researching the nature of water in a qualitative yet scientific manner. This approach was inspired by J. W. von Goethe and the anthroposophy of Rudolf Steiner.

Schwenk's seminal work is entitled *Sensitive Chaos*, first published in 1962. This book has inspired many artists and scientists since then. Founder of the *Institute for Flow Research* in the Black Forest (Germany), Schwenk worked with the mathematician George Adams, the developer of *Projective Geometry* (capable of describing aspects of reality such as life processes). Adams' work was taken up by Lawrence Edwards (see further).

Together, Schwenk & Adams discovered that the curved vortex shape prevalent in the movements and forms of cosmic activity was also present in the morphology of plants, the movements of water, the form of buds, & eggs, the ventricles of the heart etc... Schwenk was thus moved to question whether water itself is "*subject to living, formative forces and creative ideas of which it is but the visible expression*".

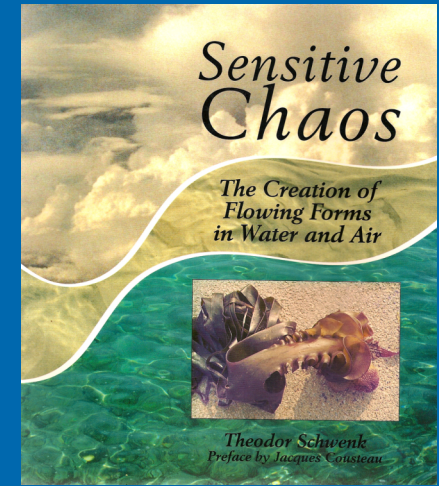

## The Drop Picture Method

A scientific process called the Drop Picture Method shows that the surface patterns of water can have a profound significance. What is actually photographed are delicate movements, affected by surface tension, between specific layers of water.

The results give indications of the health of water: healthy water exhibits rosette patterns, streaming from the central drop point; polluted or devitalized water exhibits truncated radiation and none of the blossom-like vortices.

This method shows the influence on water of what Rudolf Steiner called the "*etheric formative forces*" of nature.

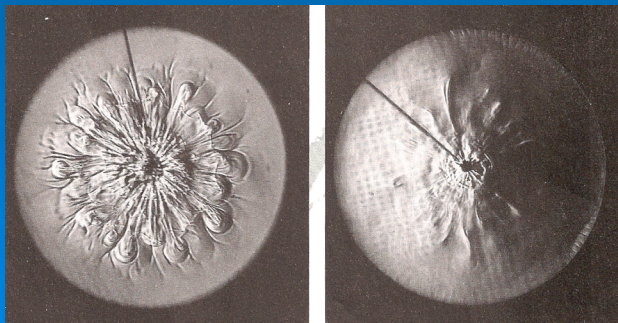

← Drop pictures:  
Left: healthy water.  
Right: polluted water.



↑ → Trains of vortices formed behind a wide rod pushed through water. (T. Schwenk)



↑ Schwenk observed that the spiraling movement of water appeared everywhere. Above: the auditory nerve fibers and a unicellular water form.



# SG203.5.3.2 Theodor Schwenk & George Adams (2)

## Projective Geometry

We present here some "path curves" drawings by George Adams.  
 (From his book: *The plant Between Sun and Earth*. 1982.)

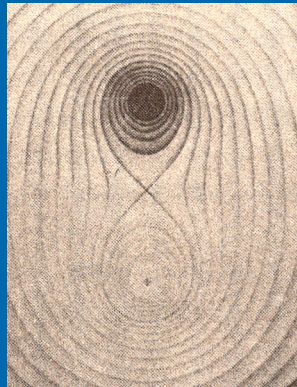

→ Path-curve model after Adams. From: Wilkens, Jacobi, Schwenk. *Understanding Water*. 2005

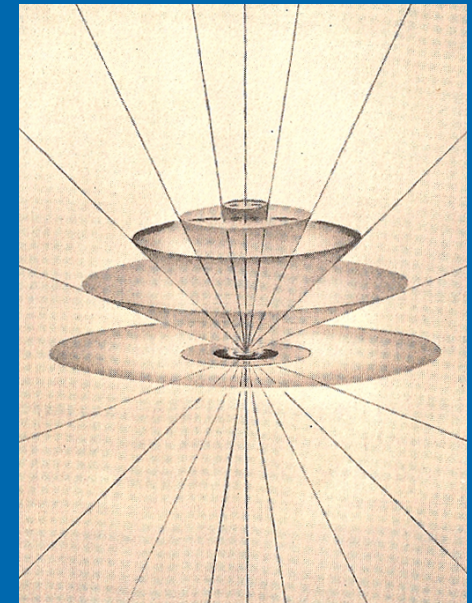
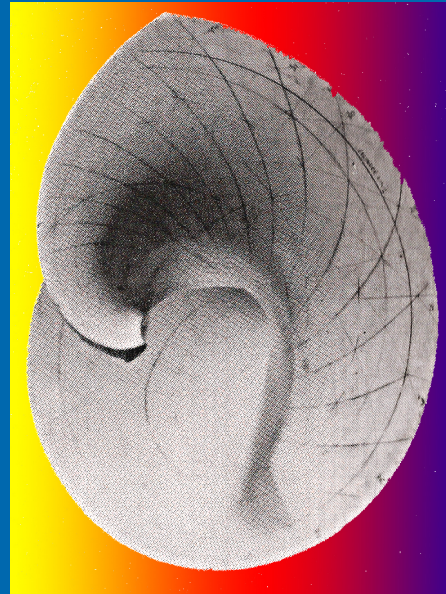

### What is "Counter Space"?

*"Counter space is the space in which subtle forces work, such as those of life, which are not amenable to ordinary measurement. It is the polar opposite of Euclidean space. It was discovered by the observations of Rudolf Steiner and described geometrically by George Adams and others. Instead of having its ideal elements in a plane at infinity it has them in a "POINT at infinity". This point is called the "counter space infinity", so that a plane incident with it is said to be an ideal plane or plane at infinity in counter space. It only appears thus for a different kind of perception, namely a peripheral one which experiences such a point as an infinite inwardness in contrast to our normal perception which experiences an infinite outwardness."*

From [www.nct.anth.org.uk](http://www.nct.anth.org.uk)

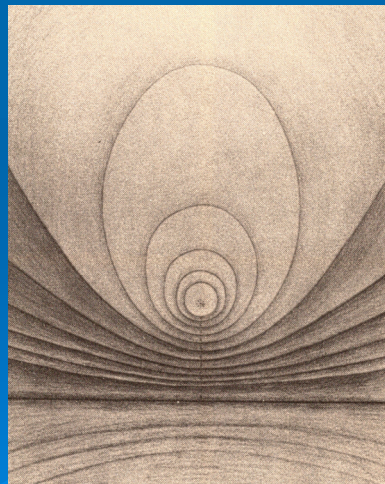

(G. Adams)

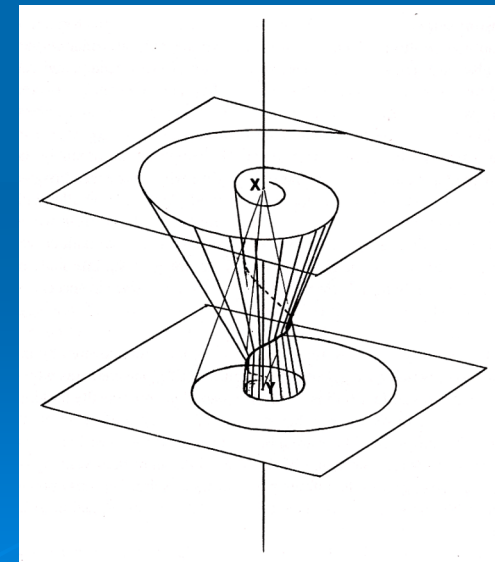

↑ The path curve followed by any general point of space lies on the intersection of two spiral cones. (L. Edwards)



## SG203.5.4.1 What is a Vortex? (1) Single

Any spiral motion of energy swirling rapidly around a center is a *vortex* (plural: *vortices*). Science first saw vortices through the laws of fluid dynamics, but the dynamics of vortices is now observed in many domains: the vortex may actually be the primordial, archetypal dynamics of the universe, from atoms to galaxies.

- A single vortex is the observed half or polarity of a full, "universal" vortex.
- A Double vortex is variously understood as a harmonic balance of two complementary polarized forces or a complete dynamics of energy-information transmission, in the context of a inter-dimensional cosmology.
- A Golden vortex incorporates the Phi-based self-similarity of the Golden spiral.

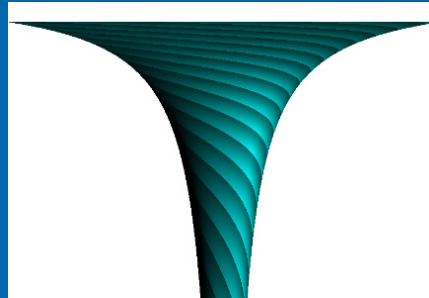
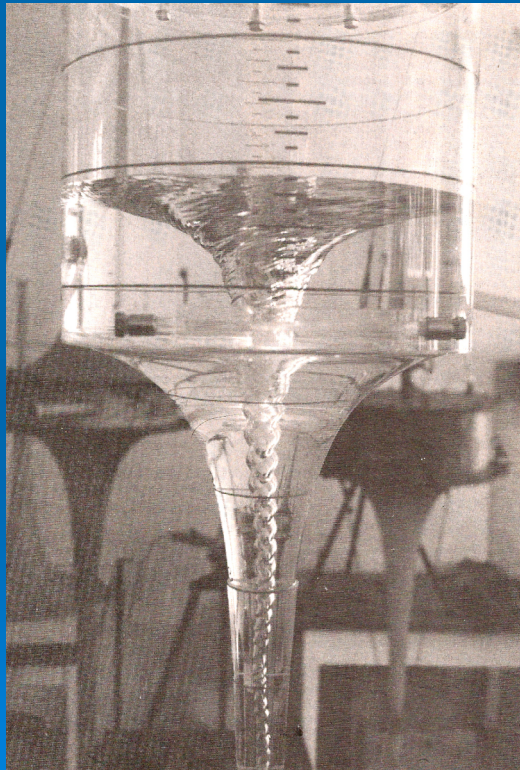

↑ A water vortex. (L. Edwards)

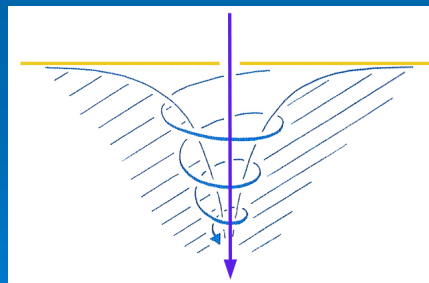

↑ Centripetence of a vortex: the spiral dynamics always seeks a center.

### Energy is primary - the cause Form is secondary - the effect

Energy creates the form in which it wishes to move.  
The form is therefore the mirror of the energy flow.

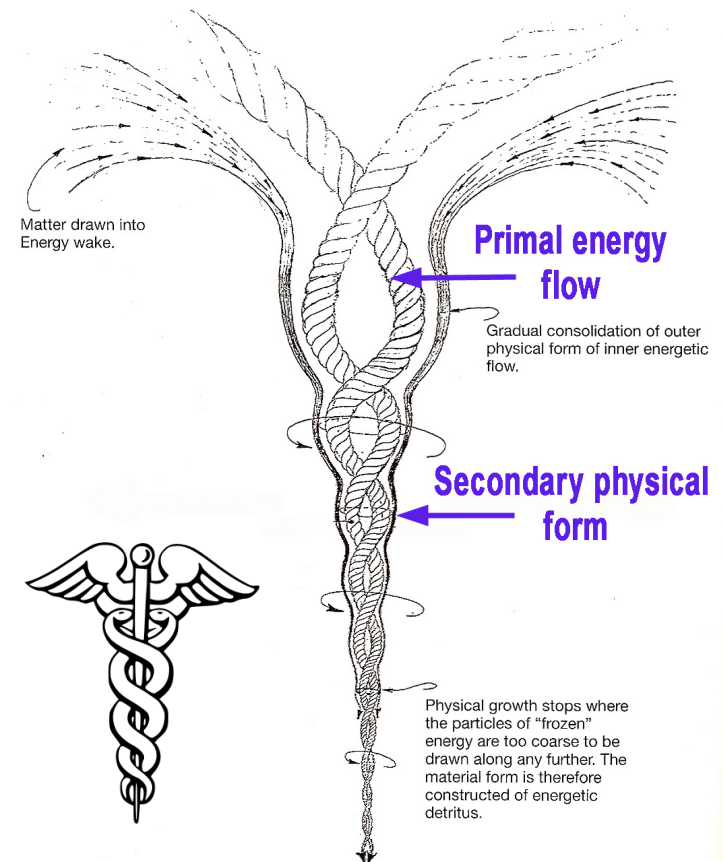

↑ "A vortex, with increasing charge (life-energy) and rotational velocity, into which more & more and higher qualities of energy are drawn for the generation and development of the form itself."

(Callum Coats. *Living Energies*.)

# SG203.5.4.2 What is a Vortex? (2) Double

Various depictions of a vortex system.



↑ 3D vortex. Dan Winter

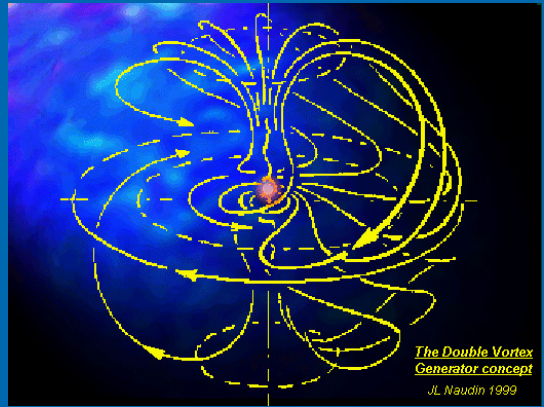

↑ Concept for the Bipolar -Vortex generator.  
J. I. Naudin // [jinaudin.free.fr](http://jinaudin.free.fr)

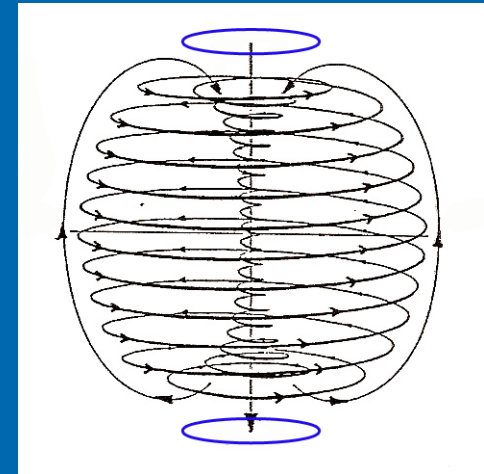
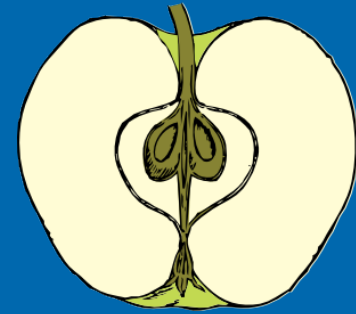

← Theosophist concept of the *Anu*, the universal atom as a vortex.

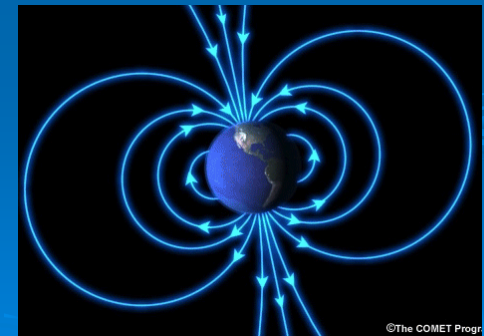
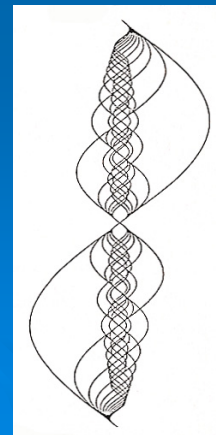
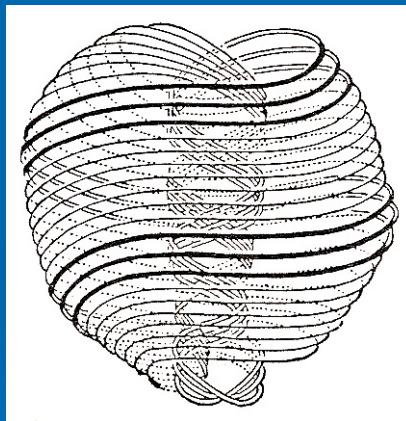
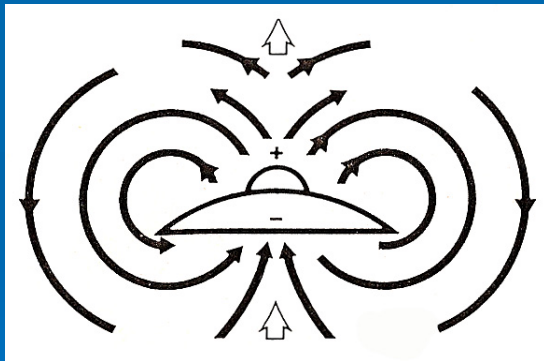

← Musical vortex as scales of overtones.

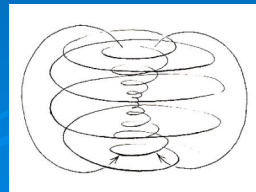
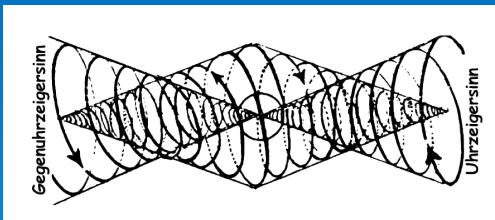



## SG203.5.4.3 What is a Vortex? (3) DIY Experiment

In the "Vortex Lab" page of his innovative research website (dedicated to the search of free-energy solutions and new generations of space-propulsion systems), Jean-Louis Naudin offers the simplest *Do It Yourself Vortex* experiment to watch an open vortex.

Here is the link: [//jnaudin.free.fr/html/vtxbottle.htm](http://jnaudin.free.fr/html/vtxbottle.htm)

### INSTRUCTIONS:

- Step #1: Recycle two round plastic bottles (like 2 liters soda).
- Step #2: Glue the two caps together, top to top.
- Step #3: drill a 9 mm hole in the center of the caps.
- Step #4: Fill one bottle up to 3/4 volume.
- Step #5: Screw the two bottles together, give a few swirls to the top bottle (to engage the vortex)... and watch!

Alternatively, get an Italian wine glass bottle (Chianti or such) that is well rounded. Get a funnel (glass looks better or plastic) with an 8-10 mm opening and place it on top of another round bottle. Fill the bottle and turn it over into the funnel.

Now, give a few vigorous swirls... and watch!



↑ Vortex in a bottle... in Sedona.

### The Vortex Sphere

For the study of a closed vortex in motion, go here: [//jnaudin.free.fr/html/vtxsph.htm](http://jnaudin.free.fr/html/vtxsph.htm)

With this device you will be able to see and study by yourself the path of the fluid flow while the vortex is active.



↑ Vortex Sphere

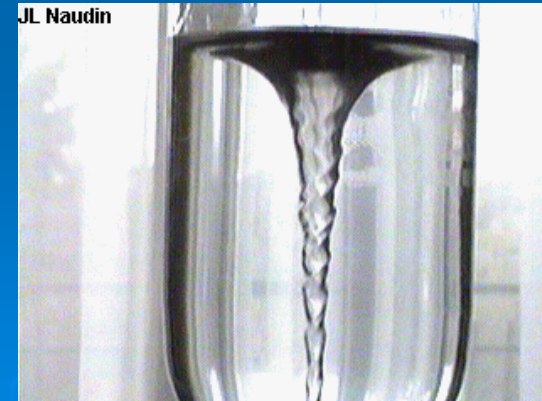



## SG203.5.5.1 Walter Russell (1) The Universal Vortex

Walter Russell (1871–1963) was an American multi-talented artist-scientist known for his achievements in painting, sculpture, architecture, and for his unified theory in physics and cosmogony. He was referred to as "the man who tapped the secrets of the universe". After his death, Russell was hailed as the "Leonardo da Vinci of the 20th century".

In 1921, Russell went into a mystical illumination experience for 39 days and nights; during that time he "saw and understood how the universe was created". In 1926, Russell published *The Universal One*, an exposition of his grand unified theory, where he posited that the universe was founded on a unifying principle of rhythmic balance and interchange represented by the dynamics of the vortex. His cosmogony was further qualified in *The Secret of Light* (1947) and *A New Concept of the Universe* (1953).

The Swannanoa estate, Virginia, was the setting for Russell's *University of Science and Philosophy* from 1946 to 1998. He lived there with his second wife Lao Russell till May 20, 1963. Lao continued his work at the University until May 5, 1988.

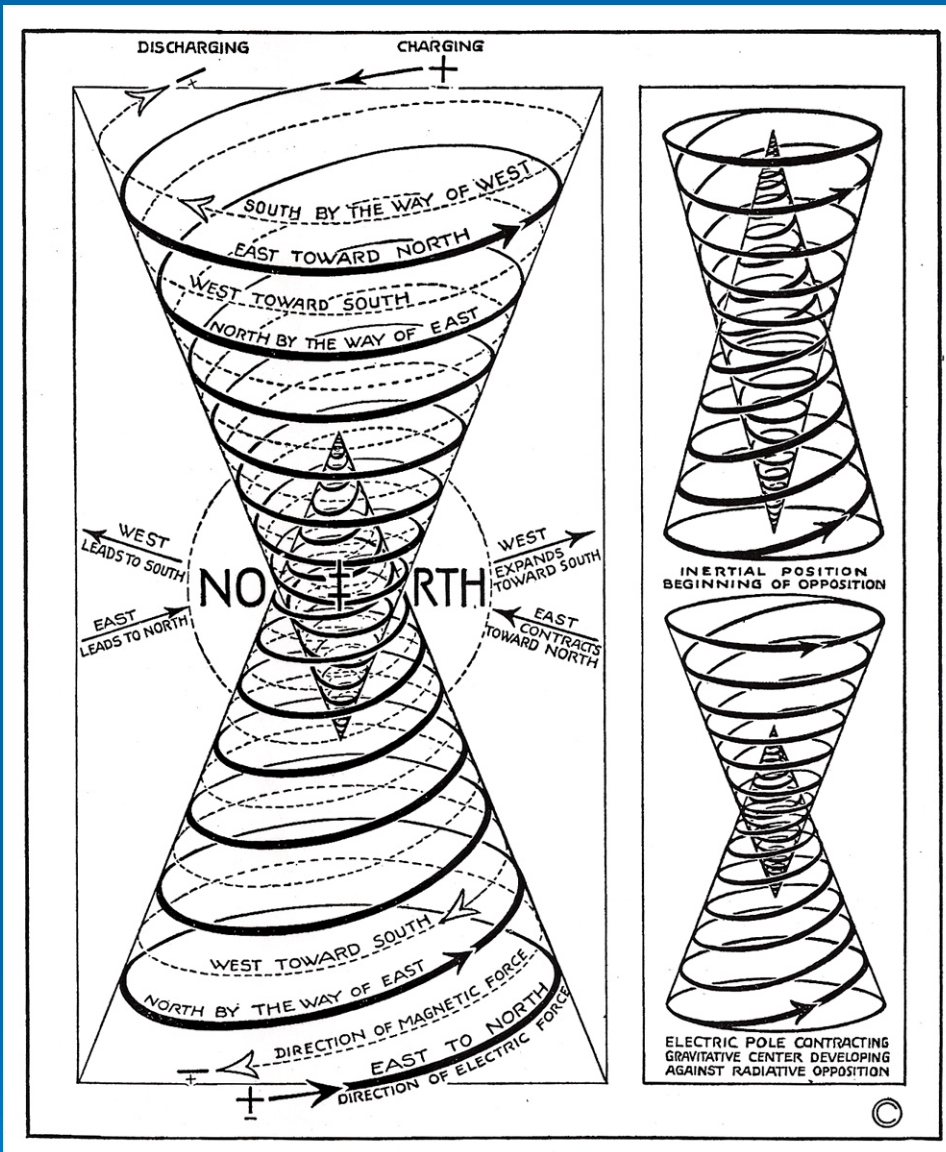

"A vortex is formed by the contraction of the axes of two opposite cones of energy. The greater the contraction, the greater the acceleration of motion within the vortex."

(W. Russell. *The Universal One*.)

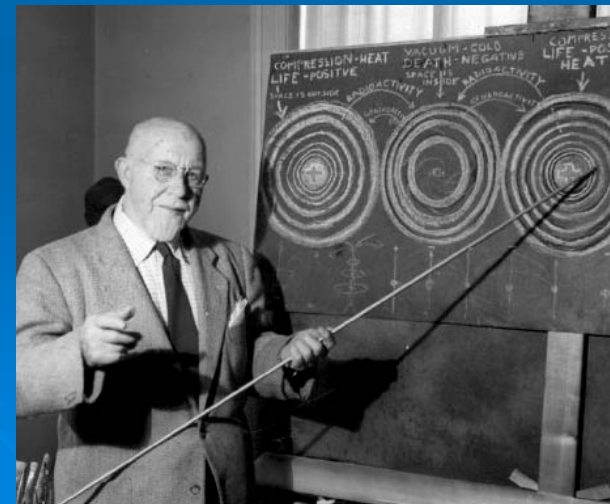

← Walter Russell

# SG203.5.5.2 Walter Russell (2) The Tornado Principle

## THE TORNADO PRINCIPLE

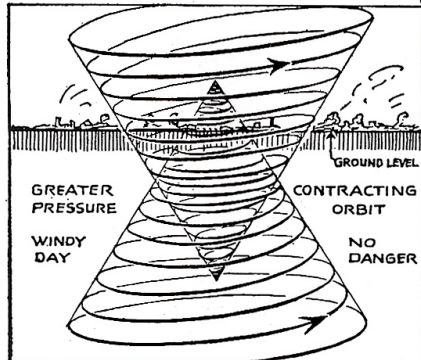
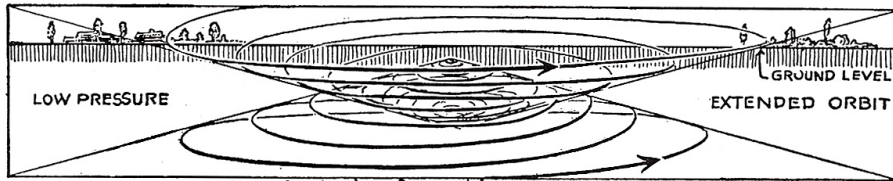

The vertices of contracting cones are the danger points.

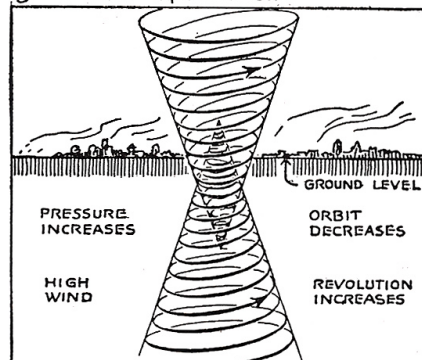

Energy is generated in contracting cones.

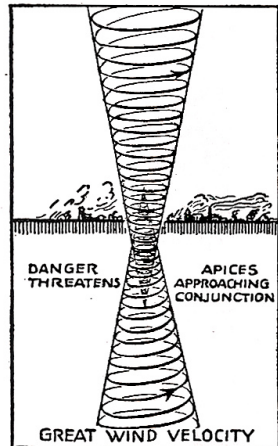

The apices of contracting cones draw toward each other. The gravitative center contracts to a point of north.

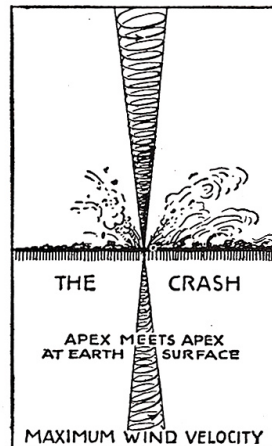

Energy formerly extended over wide area is concentrated in a point of north.



FROM ACTUAL PHOTOGRAPH—  
THE CYCLONE  
Wind velocity and force (speed time and power-time) decreases in universal ratio within the cone from the apex to base. Because of small magnetic base the wind velocity decrease is very small.

(W. Russell. *The Universal One.*)

## EXPLAINING ACCELERATION & DECELERATION OF ROTATION

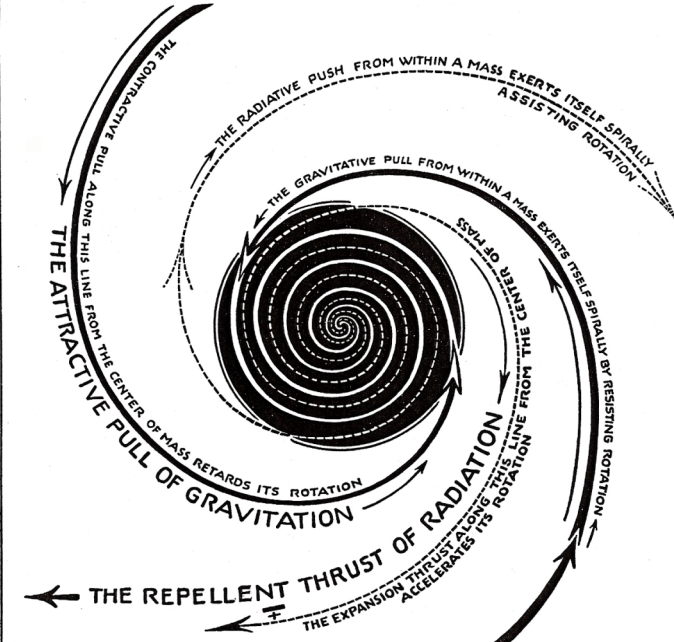

The electro-positive force of attraction pulls INWARD from WITHIN. The electro-negative force of repulsion pushes OUTWARD from WITHIN. Contraction and expansion from within are two opposing forces, one battling for the slow rotation of centripetal force and the other for the fast rotation of centrifugal force. All masses begin their accumulation with generative preponderance. It is the attractive, contractive pull from within a vortex which causes mass to form because of the increasing attractive pull of charging bodies. It is the expansive thrust spirally away from a vortex which causes mass to decompose because of the increasing repulsion of discharging bodies.

The opposing forces of gravitation & radiation.  
(W. Russell. *The Universal One.*)

*"Nothing can be of itself alone.  
All things are universal  
ONE."*

Walter Russell



# SG203.5.6.1 Lawrence Edwards - The Vortex of Life

Lawrence Edwards, a mathematician and scientist from Scotland, has been studying, for more than 60 years, the shape of natural forms. His dedication has brought amazing data to science. First in *The Field of Form* (1982) and then in *The Vortex of Life* (1993), Edwards was concerned with the relationship of the "outer world of living forms and the inner world of geometrical imagination". Like Schauburger, his teacher and model was nature.

In the *Vortex of Life* (1993, 2006), Edwards gave a full account of his research, widening it to include the forms of plants, embryos, eggs, and organs such as the heart. His work suggests that there are universal laws, not yet fully understood, that guide an organism growth into predetermined patterns. His work has profound implications for scientists working in genetics and stem cell research and anyone realizing that the universe is based on a cosmic matrix of geometric, fractal harmonics, i.e. Sacred Geometry.

## Path Curves

It was one of [Lawrence Edwards'](#) many discoveries that invariant curves from Projective Geometry known as PATH CURVES very accurately describe natural forms and subtle aspects of reality such as life-processes. By using a single parameter (*lambda*) for the shape, he was able to study very subtle daily changes in bud-like forms.

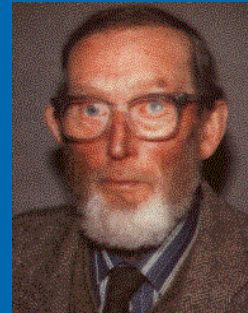

Lawrence Edwards  
(1912 - 2003)

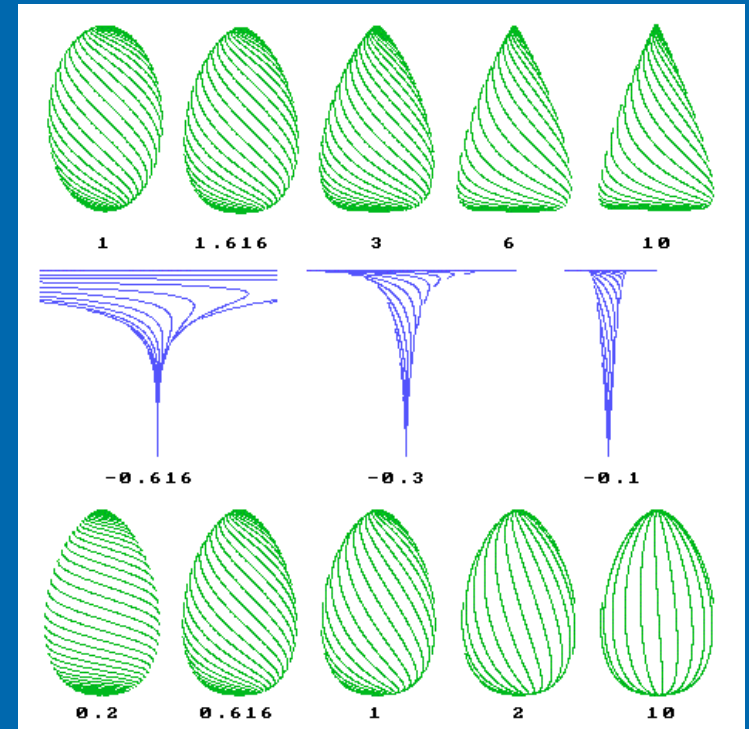
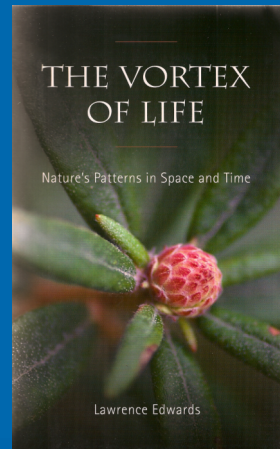

↑ The variation of two parameters: *lambda* and *epsilon*. *Lambda* controls the shape of the profile and *epsilon* determines the degree of spiraling. *Lambda* is positive for eggs and negative for vortices, while the sign of *epsilon* controls the sense of rotation. The profile is thus controlled by a single parameter (*lambda*), and it is scientifically interesting that with such a restriction these curves fit very closely a wide variety of natural forms: eggs, flower & leaf buds, pine cones, the left ventricle of the heart, the pineal gland, and the uterus during pregnancy.

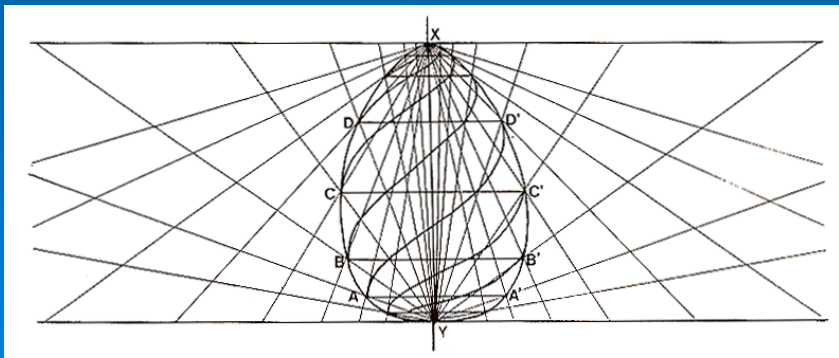

↑ Construction for the spiral path curves on an egg surface. (L. Edwards)

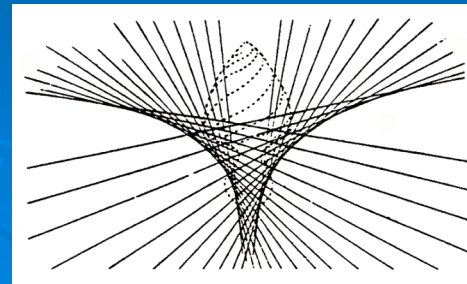

← The form of the rose led to the concept that the rose would mediate between a planetary vortex and the form of the rose hip. (Edwards).



# SG203.5.6.2 Lawrence Edwards - The Web of Life

Using an invariant parameter (*lambda*) that is a measure of a bud's shape, Edwards has observed that, every 14 days, the bud evolves by changing its shape from a flattened to a more sharpened form.

After more than 50,000 nearly daily observations, he has been able to show that, for a particular species of bud, the time of maximum change correlates with the alignment of the earth, moon and a planet particular to that species. For example, the oak correlates with Mars, the beech with Saturn and the knapweed with Jupiter.

Moreover, each year the time at which the bud achieves its maximum change of shape occurs one day per year earlier than the exact alignment of earth, moon and planet. Then, seven years later, the alignment is exact again.

Says Jay Kappraff: "These observations have no explanation within the scientific paradigm. However, the results have been duplicated". (J. Kappraff: *Anatomy of a Bud*. [www.mi.sanu.ac.rs](http://www.mi.sanu.ac.rs))

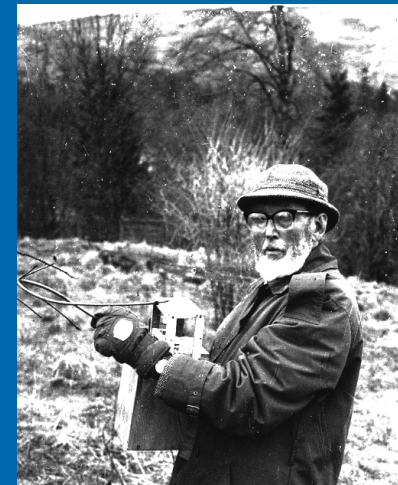

↑ Lawrence Edwards measuring a bud with his special apparatus.

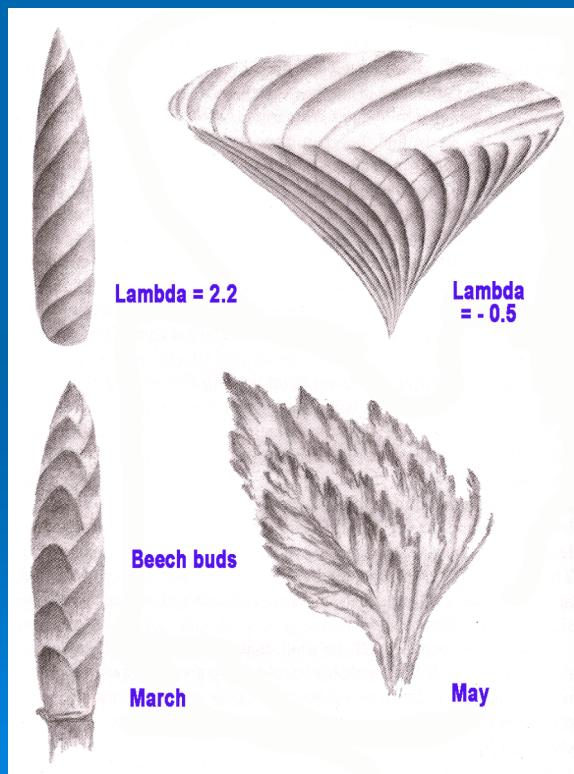

Edwards' observations of rhythms (in-breathing / out-breathing) in buds led him to study the heart. He found a seven-fold pulse in the heart's beat, which he correlated with the 14-day rhythm in buds and the 7-year rhythm in the phase-shift.

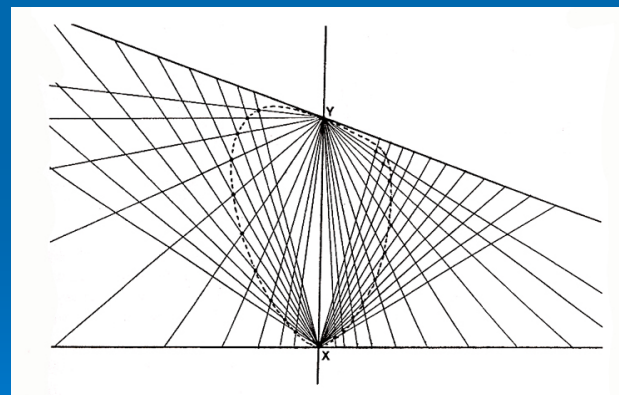

← Above. Geometric model: a decrease in Lambda changes the bud into the open chalice of the vortex. Below. Nature: springtime (between March & May) transforms the tightly-closed bud into the open whorl of new leaves.

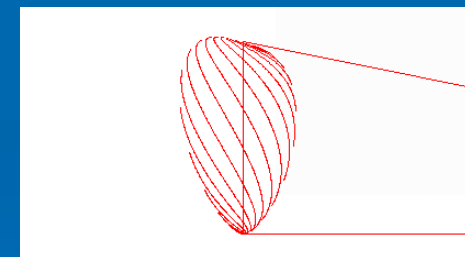

← The heart's left ventricle follows closely the ideal path curve form.

↑ The way the left ventricle of the heart behaves as a path curve, from diastole to systole. (Animation)

# SG203.5.7.1 Golden Vortex

## (1) Torus

Any spiral motion of energy around a center is a *vortex*. As such, the vortex may well be the primordial dynamics of the universe, from atoms to galaxies.

A vortex flow is usually associated with a *torus*, specially the “*spindle torus*” which allows for a double polarity flow.

When the Golden Spiral maps onto it, a vortex becomes a Golden Vortex, embodying the Phi ratio. The Golden Vortex is the ideal vortex optimizing the most efficient transfer of energy/information.

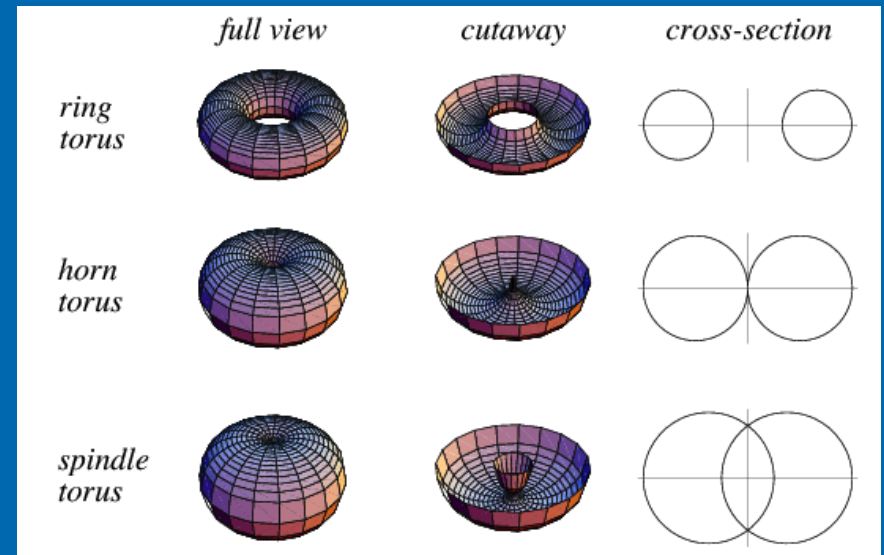

↑ Standard *tori* // [mathworld.wolfram.com](http://mathworld.wolfram.com)

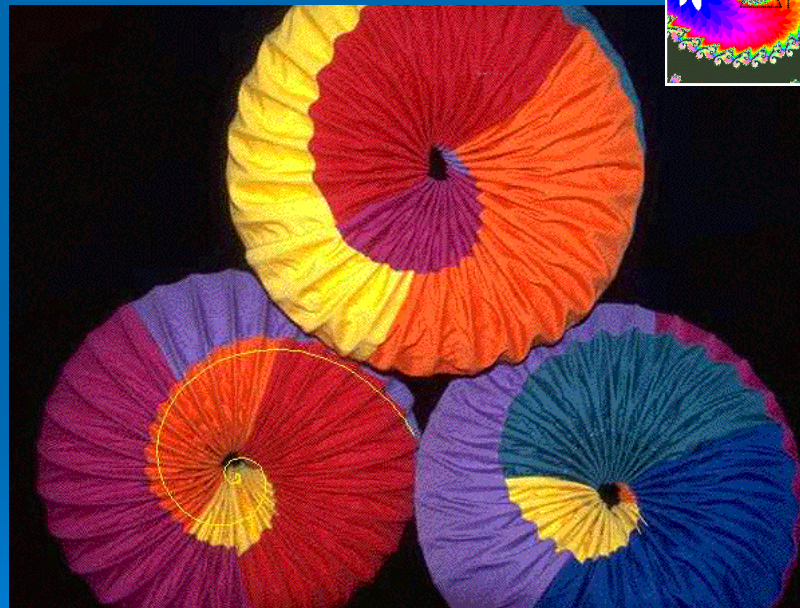
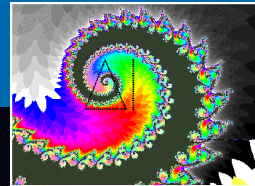

↑ The Golden Mean Spiral maps out a 7-colors “rainbow donut” torus.

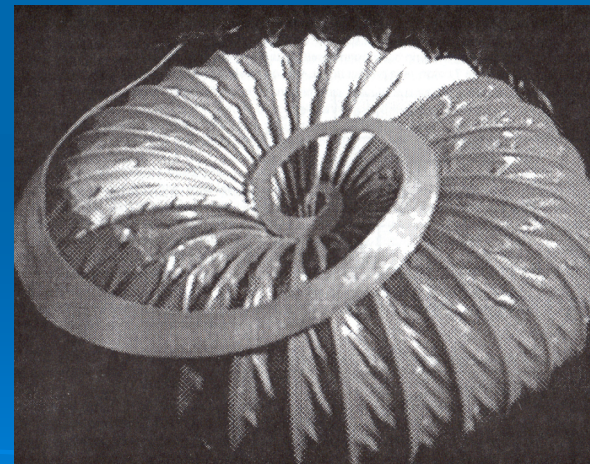

↑ The Golden Spiral turns a torus into a Golden vortex

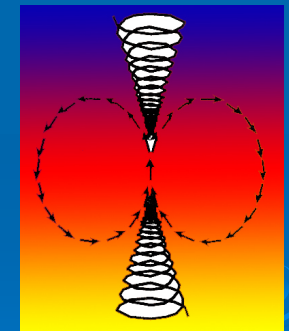

↑ The vortex in the torus



# SG203.5.7.2 Golden Vortex (2) Phi Implosion



*"The harmonic of the double cycloid spiral curve (the 'vortex') is based on Phi, the specific formative principle expressed mathematically by the ratio 1 :: 1.618 or Fibonacci Cycle."*

(Frank Germano, engineer)

*"Phi is the only permissive path from matter to energy and back. The mathematical image of the condition of pure self reference."*

(Dan Winter, engineer)

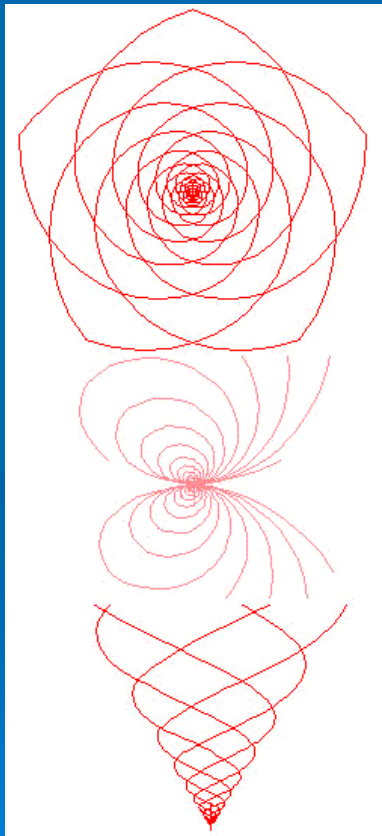

↑ 3 views of the spiral spin path of the Golden Vortex

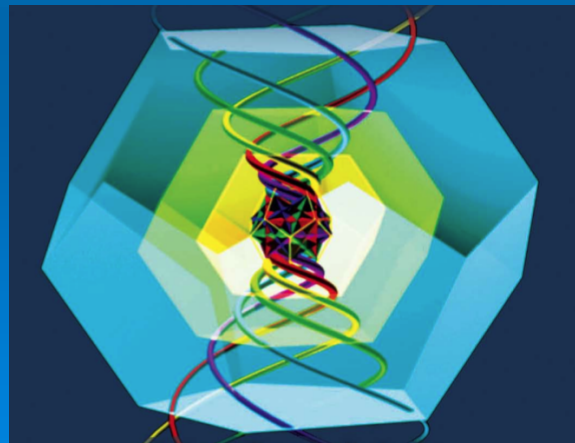

↑ The Golden Vortex mapped unto the dodecahedron.

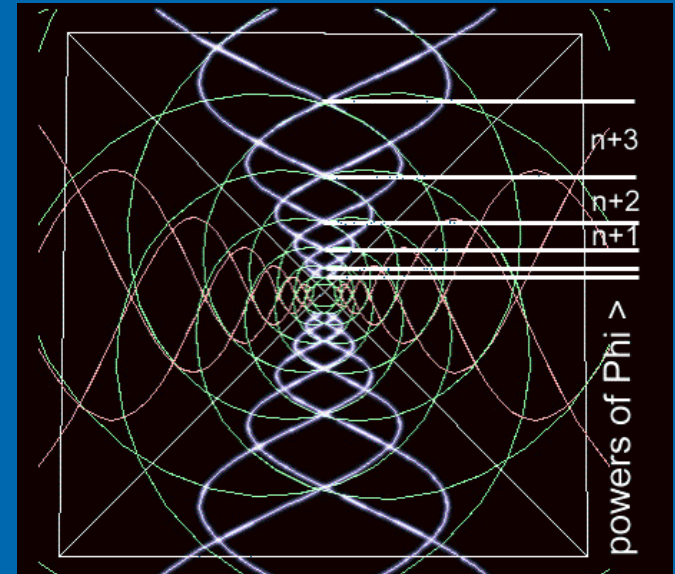

(All images & animations by Dan Winter [www.goldenmean.info](http://www.goldenmean.info))

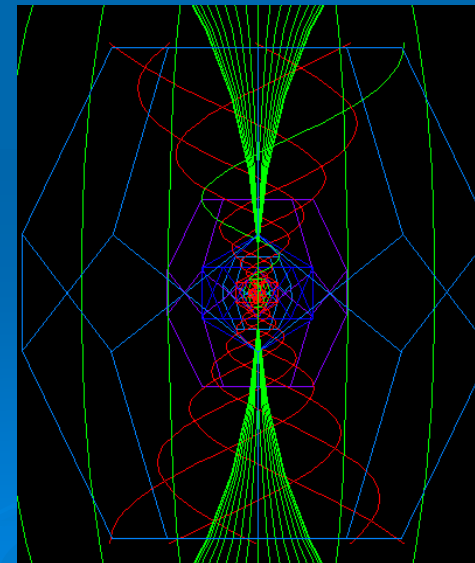

↑ Animation



# SG203.5.7.3 Golden Vortex (3) Phi Cascade

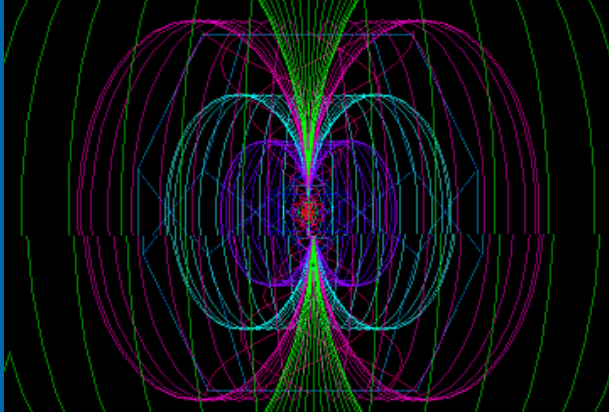

↑ The Golden Vortex. Side view. Animation.

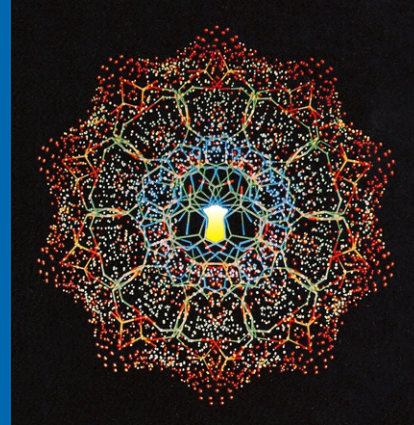

↑ Top view of DNA

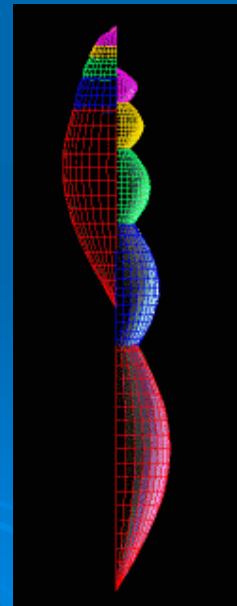
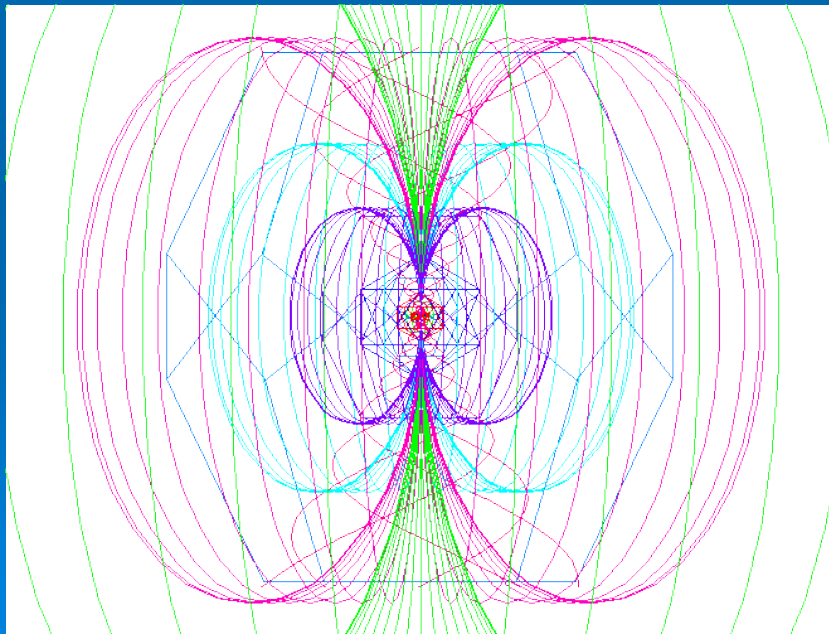
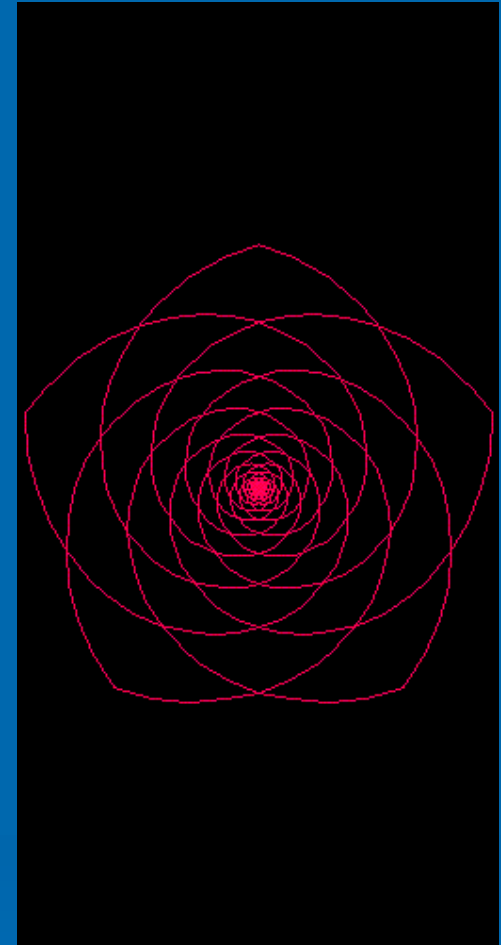

All images and animations by Dan Winter.  
<http://www.goldenmean.info>

# SG203.5.7.4 Golden Vortex (4) Grail Cup

Dan Winter has shown that the spin path geometry of the Golden Spiral/Vortex forms a "Grail Cup" that is the key to:

- the perfect compression of fractality
- the "Zero Point" & Implosion energy
- the heart's compassion/love harmonic pulses

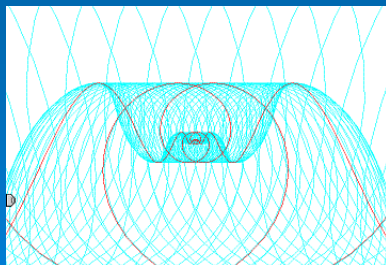
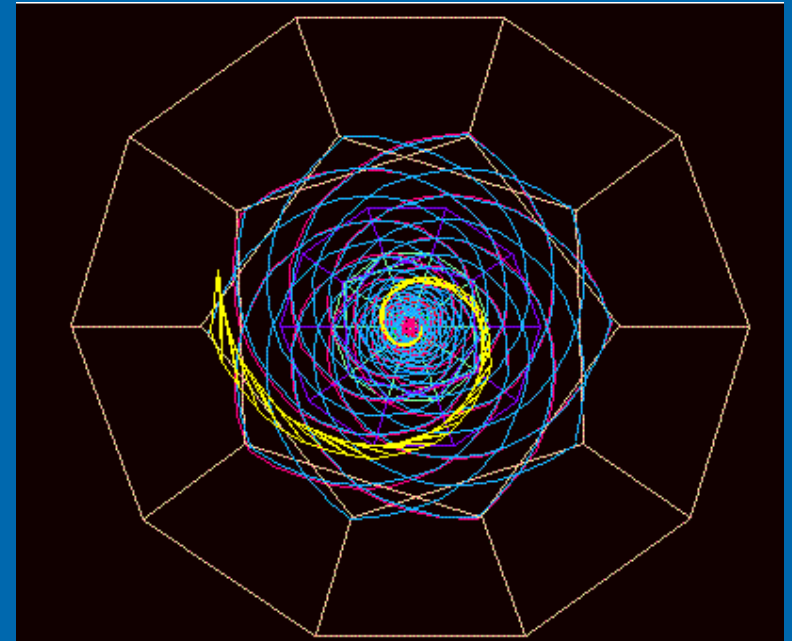
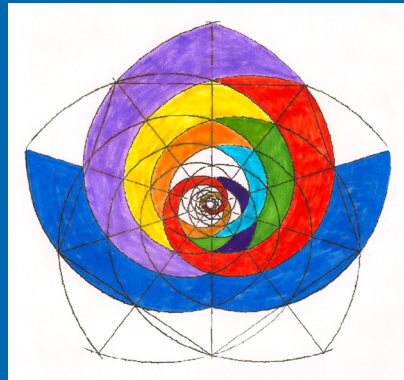
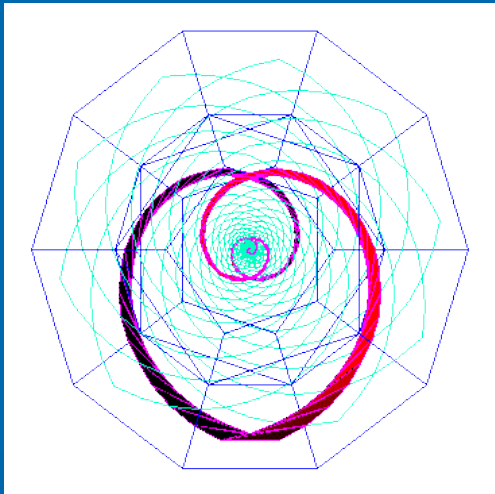

↑ Animation

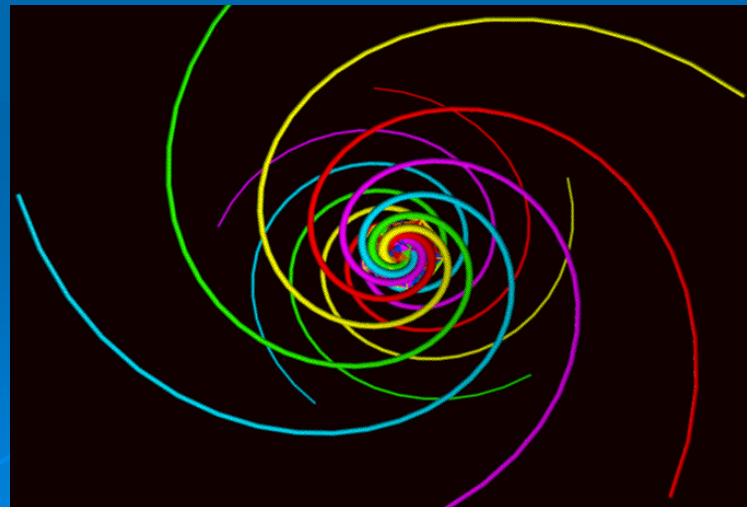

When the Golden Spiral self-embeds perfectly, it provides a harmonic spin path for atomic vortices, DNA, flowers, people and galaxies... to enter the Dance of Life.

<http://goldenmean.info>

# SG203.5.8.1 Latest Science (1)

## Polygonal Vortices

If you were flying over the Earth's South Pole, you would see a "polar vortex": a huge swirling mass of clouds and winds in the upper atmosphere right above the pole, driven by the Earth rotation. The centre of the vortex is usually circular, but occasionally it assumes a triangular or even a square shape. This curious behavior has also been photographed on other planets of the solar system.

The fact that vortex walls could develop wavy instabilities had been first proposed in the 19th century by Lord Kelvin. Also, in his *Treatise on Vortex Rings* (1883), British physicist J. J. Thomson calculated that, as the angular velocity of the vortex increased, the system would form polygonal geometries or "vortex rings".

Recently, this feature of vortical flows has been replicated & proven in the laboratory:

- In 1979, Richard Packard and colleagues (UC Berkeley) saw as many as 11 vortices in a rotating cylinder of superfluid helium.
- In 1990, Georgios Vattistas (Concordia U, Montreal) observed the same appearance of polygonal geometries.

As reported by [physicsworld.com](http://physicsworld.com), "Vattistas's team studied water vortices in a stationary cylindrical bucket with a rotating disk at its bottom. As the disk spins, it causes a whirlpool to form in the bucket. The centrifugal effect causes the water to climb the wall of the bucket, leaving a depression in the centre. If the disk is spun fast enough, the depression reaches right to the bottom of the bucket and the centre of the disk has no water on it. The researchers used a digital camera to take one photo of the dry region per revolution using a synchronized stroboscope. Initially, the dry region of the disk was circular but as the angular velocity of the disk increased, the dry region split into two lobes, followed by a triangle, square, pentagon and hexagon. Despite further increases in angular velocity, the team saw no evidence of polygons with seven or more sides."

- For centuries, liquid droplets have fascinated scientists (such as Gauss, Poincaré, Chandrasekhar, Bohr and Wheeler). Belgian physicist Plateau (famous for his experiments with soap bubbles) discovered in the 1860s that a spinning droplet becomes deformed into a two-lobbed peanut-shape when rotating fast enough. In 2008, Richard Hill & Laurence Eaves (U Nottingham, England), used strong magnetic fields to levitate droplets of water as big as 14 mm in diameter. The drops were spun by passing an electric current through them. Hill and Eaves observed the development of 3, 4 and 5 lobes corresponding to triangular, square and pentagonal geometries. (Refer to experiments in water cymatics [◆SG201.5](#))

**In a fluid or plasma, ROTATION can break the circular symmetry and create polygonal geometries.**

In the context of Sacred Geometry and the special role in nature of penta-symmetry and its Golden ratio, the study of the conditions of velocity and other parameters that are necessary to produce each type of polygonal vortical structure will certainly reveal fascinating facts.

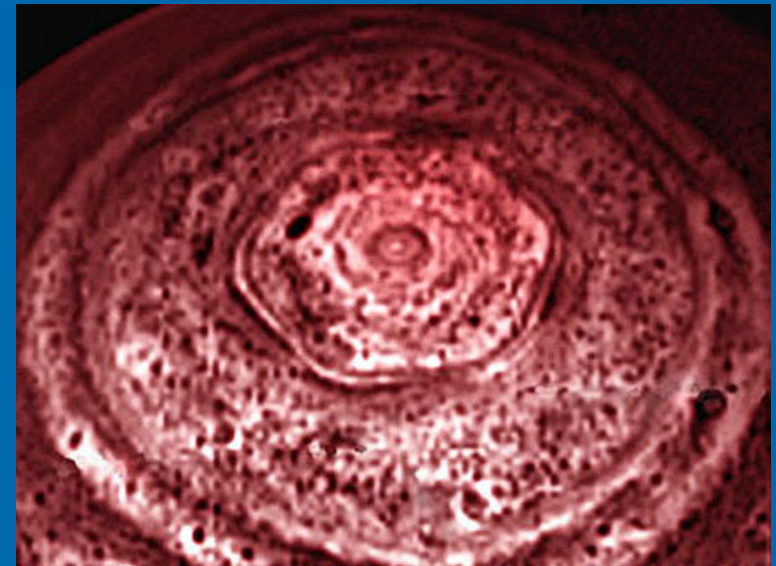

↑ Hexagonal geometry of Saturn's North pole. NASA.

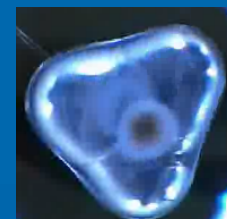

↑ Tri-polar geometry of a water drop under rotation. (Hill and Eaves). [//physics.aps.org](http://physics.aps.org)



↓ ↑ Polygonal vortices. G. Vattistas

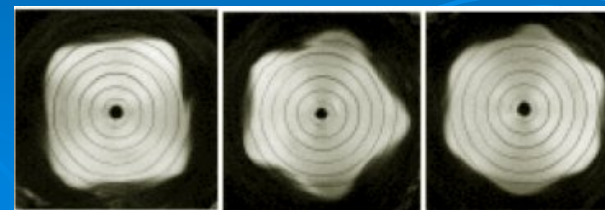



## SG203.5.8.2 Latest Science (2) Solitonic Vortices

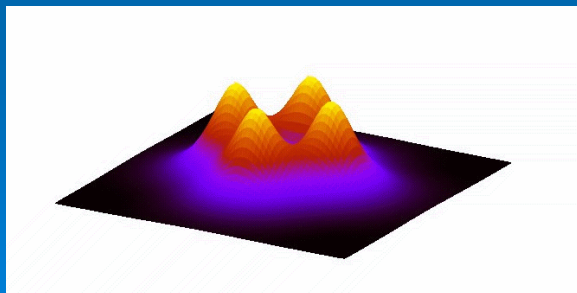
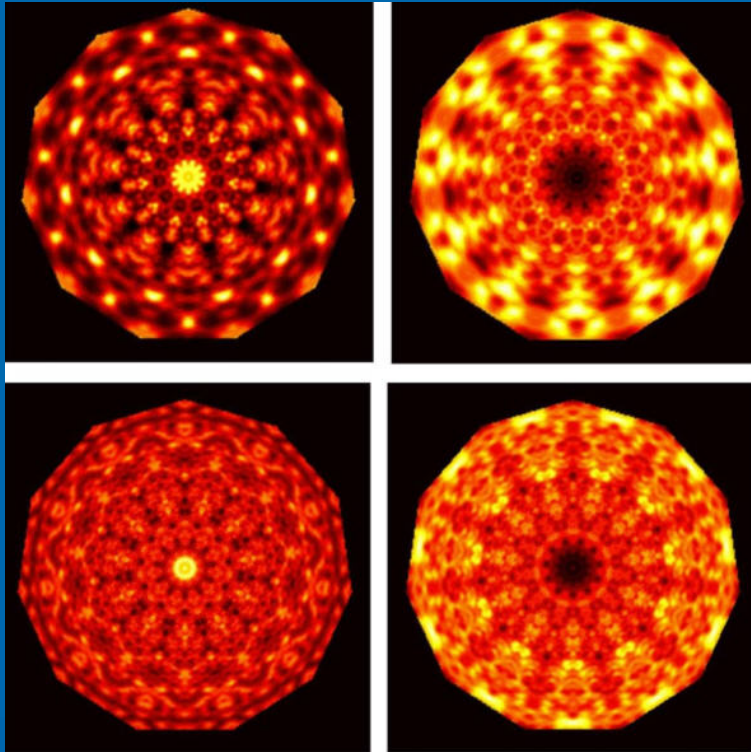

↑ Four non-linear beams  
in a nematic (long axes parallel) liquid crystal.  
[www.maths.ed.ac.uk](http://www.maths.ed.ac.uk)

Solitons and vortex rings →  
are examples of nonlinear wave  
phenomena, which maintain  
their shape during  
propagation.

The experiment at Harvard  
University showed evidence of  
unexpected shell-like  
structures. Simulations give  
evidence that these structures  
are hybrid objects composed of  
soliton fronts and vortex rings.

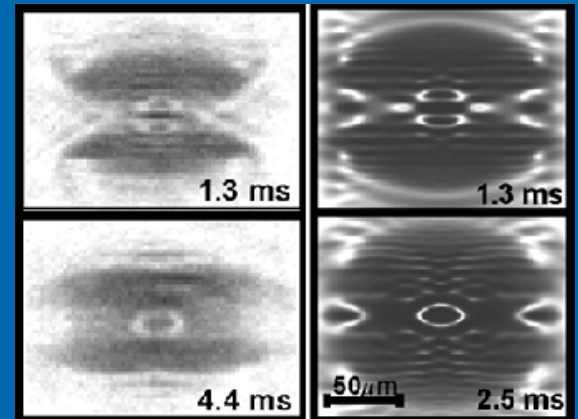

← Solitons. From: [www.cse.salford.ac.uk](http://www.cse.salford.ac.uk)

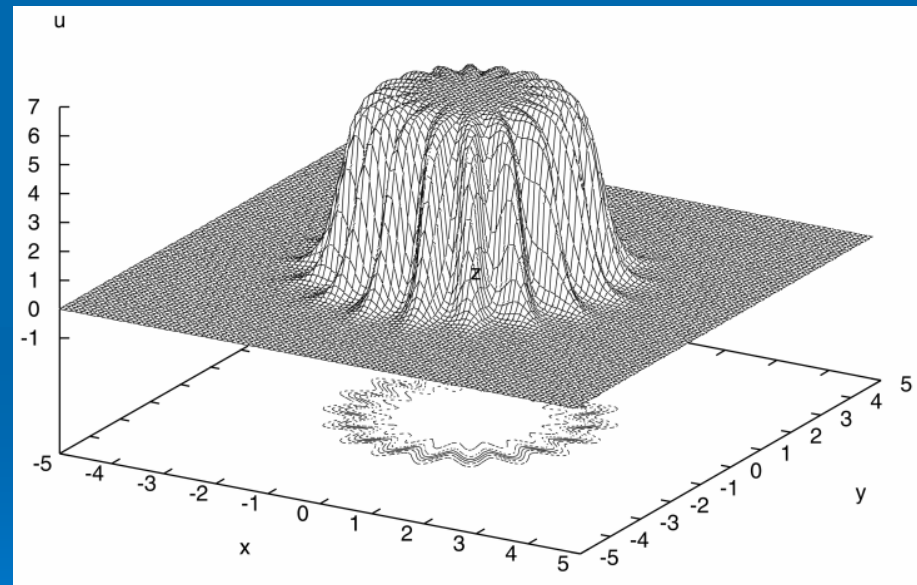

↑ Evolution of 2D lump for the Sine-Gordon equation.  
This equation has soliton solutions and arises in laser optics  
and particle physics. [www.maths.ed.ac.uk](http://www.maths.ed.ac.uk)

# SG203.5.9.1 Vortex Water (1)

## The Water Wizard

The Swedish research group headed by Olof Alexandersson has developed a current model of a machine invented by Schauberger in 1943: an egg-shaped spring water producing machine.

*"The purpose of this apparatus is to regenerate old, stale water or create new mature water from distilled water by in-rolling and out-rolling it through the creation of alternating right and left hand vortices, emulating the sequential alternation of negatively and positively charging longitudinal vortices at the bends of natural flowing rivers."* (Callum Coats. Living Energies.)

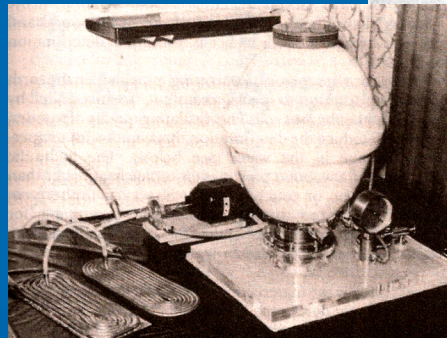
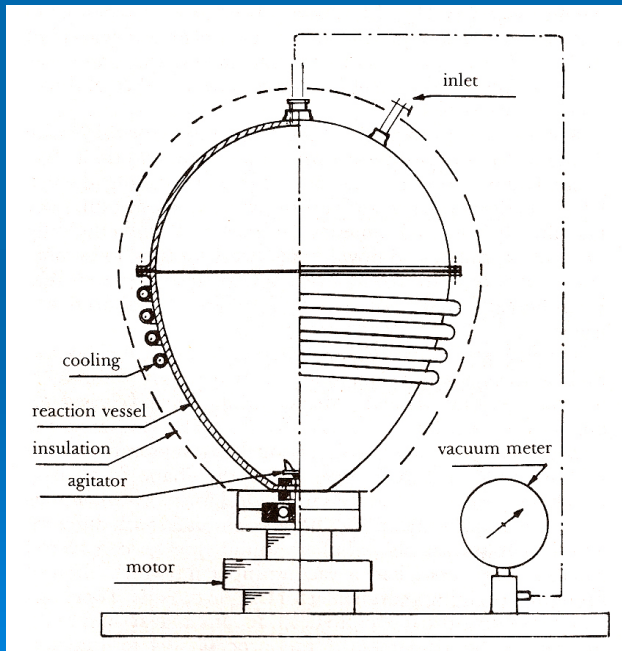

← ↑ Egg-shaped container for biological synthesis of spring water.

Institute for Ecological Technology. Sweden. (Olof Alexandersson. *Living Water.*)

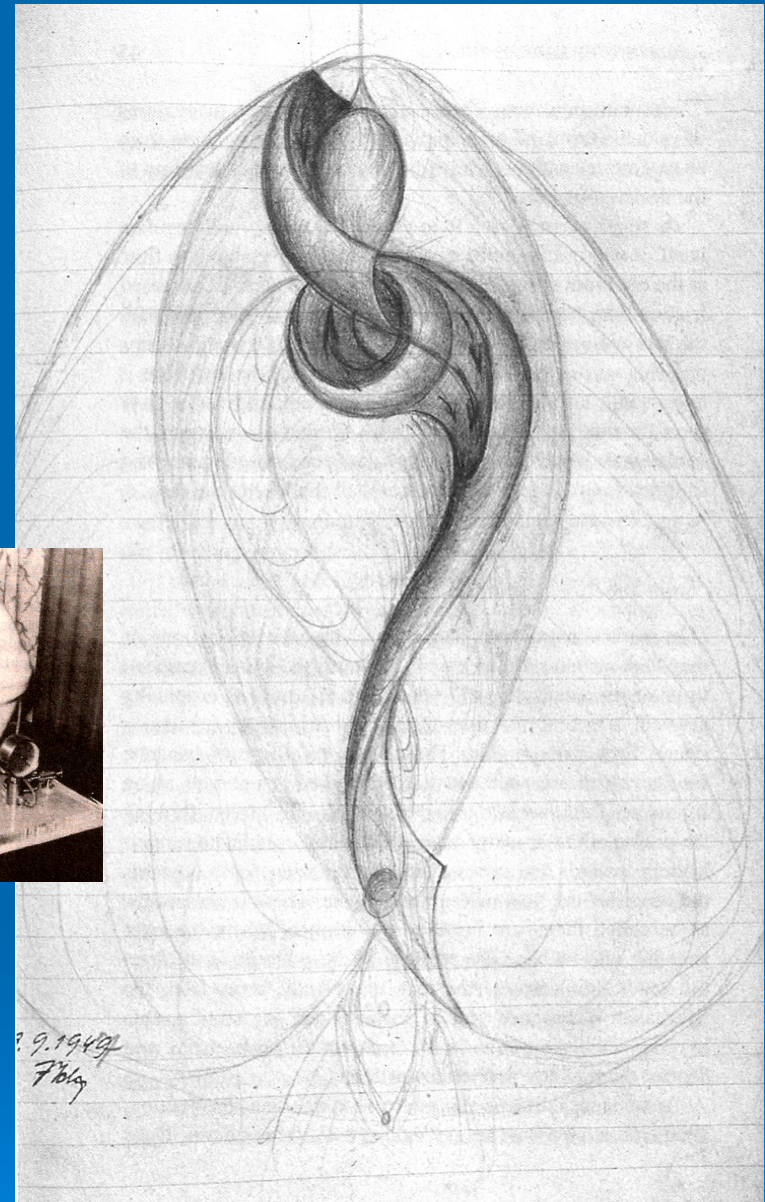

↑ Untitled drawing by Viktor Schauberger, 1949. Note the egg-shaped envelope of the water vortex stream.



## SG203.5.9.2 Vortex Water (2) Schauberger's Pipes

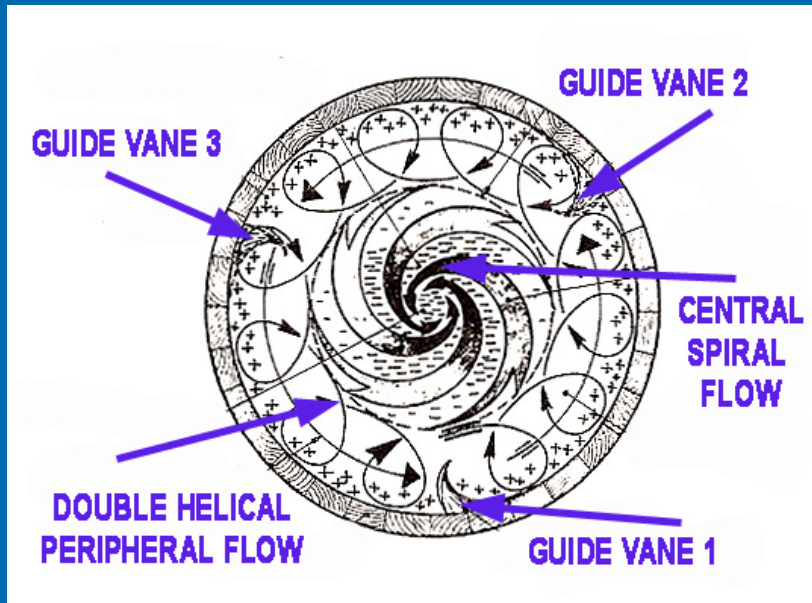

↑ Schauburger's wooden pipe with silver-plated copper guide vanes fluted so as to direct movement towards the center.

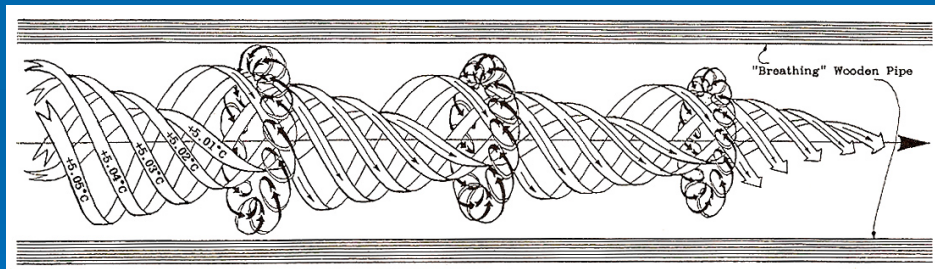

↑ The Schauburger's pipe configuration sets up a double-spiral longitudinal vortex. This creates a healthy "living water" and a flow that is faster than in a conventional pipe.

*"Water is at its most healthy and potent when it is allowed to flow as it wants to."*

(V. Schauburger)

Schauberger observed that water can maintain its vitality & energy only if it is allowed to tumble about in a spiraling vortical manner. So, in 1930, he built a pipe that would encourage the vortex motion.

Viktor Schauburger explained that a body of water attempts to mirror the 3 types of planetary motion:

- Rotation about its own axis (Cycloid motion)
- Spiral motion as the water flows on its bed, just like the Earth spirals around the sun in the course of the year.
- Space-Curve motion as the entire watercourse twists and turns, mirroring the entire solar system spinning through the galaxy.

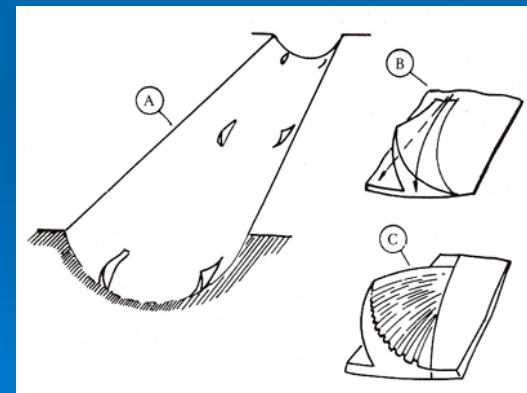

↑ By way of these obliquely placed flutes, the water is propelled into a spiral motion in the middle of the flow channel. (Schauberger patent).



# SG203.5.9.3 Vortex Water (3) Energized Water 1

## E-WATER

Energized water (E-Water) is water that has been treated in the "vortex machine" developed by Wilfred Hacheney, in Germany, in 1976. The device consists of a hyperbolic cylinder made of high grade steel and having, in the center, a funnel shaped device placed over a blade rotating at 6,000 rpm and creating a vortical path. The water is thus spun in a powerful and accelerated spiral motion.

In addition, as explained in the book *Living Water* by Olof Alexandersson (1990 edition), *"the enclosure shape and internal design of the cylinder causes a change in the direction of flow at regular intervals. At the moment of direction reversal, the water particles are subjected to extremely high acceleration, while any turbulence is avoided. This creates suction energy which is stored into the water in the form of micro-vortices."*

Here are some laboratory-proven effects of the E-Water:

- Higher quality physical and psycho-mental health.
- Plants growing in soil watered with E-Water show a faster rate of growth with a many times higher seedling survival rate.

This results in higher values for crop yield, quality and resistance to diseases and pests. Also, packaged produce and foods prepared from these plants have a longer shelf life.

- In building materials, E-Water changes the mineral structure of hydraulic binders: the presence of E-Water in cement mixtures, or clay and sand mixtures, creates unusually high colloidal states. The beneficial practical effects are numerous: higher bonding capacity of cement; higher resistance in compression and bending of concrete; chemical resistance...

## BIO-DYNAMIC WHIRLING

Biodynamic agriculture is a method of organic farming that treats farms as unified and individual organisms, with emphasis on balancing the holistic development and interrelationship of the soil, plants, animals as a self-nourishing system. Bio-dynamics was devised by Rudolf Steiner (1861 - 1925), the founder of anthroposophy. It is known that Steiner and Schauberger had lengthy discussions.

Among the methods unique to the bio-dynamic approach are herbal compost preparations based on a *"whirling technique"*. For instance, the '500' fertilizer is produced with a pulsating movement similar to the homeopathic process of succussion, whereby the state of energy or order is progressively increased through the successive creation and recreation of order and chaos... The composting liquid is stirred in until a vortex has been formed; the direction of stirring then reverses until another vortex forms. This process of repeated reversals imbues the liquid with opposite charges and draws in inseminating oxygen.

If stirred or whorled by hand, the quality of the composting liquid can be further enhanced by singing into the preparation, as witnessed by Schauberger:

*"As Viktor watched, the peasant stirred the contents to the left with large wooden paddle and sang in rising tones, only to change to descending tones when stirring to the right, all the while crumbling pieces of clay into the water. After about an hour, the peasant declared that he was now ready for spreading that the mixture was now ready for spreading over the meadow the next morning."*

(Callum Coats. *Living Energies*.)

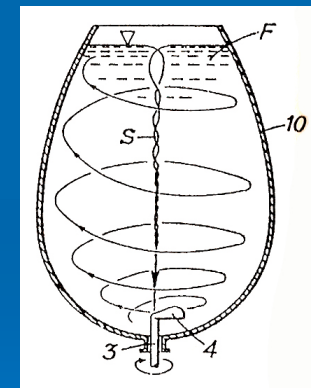

↑ Mechanical egg-shaped vessel for stirring liquid fertilizer.

The vessel should be made of fired clay, wood or copper.

## SG203.5.9.4 Vortex Water (4) Energized Water 2

It is obviously essential to drink the highest frequency water possible, as the human body is about 75% water. Bottom line is to drink directly from a high-altitude mountain stream running in an unpolluted, forested area. Short of that, level one strategy is to procure spring water that has been tested and run it through a good filtration system that takes out contaminants all the way to a micron size. Level two strategy is to re-energize your water through a number of techniques, adjuvants and products that will somehow "re-structure" or "re-harmonize" it.

However, since water is known to retain the memory of energy patterns, the top strategy is to put your water through a thorough vortexing process and thus give it the highest life-force qualities due to the complex geometry of vortical implosion. As observed by Viktor Schauberger in the European Alps, the alternation of right and left twirling is the technique used by traditional farmers to potentize their liquids. This is also the technique used by bio-dynamic farmers to prepare their liquid fertilizers. It is the best strategy to avail oneself of the basic dynamics of the universe and imprint it on the water you drink.

There are now a number of water vortex systems on the market. Some are electric, some are hand-powered... The winner, in my opinion, is the Double-Egg Vortex which puts the water through a complete vortex transmutation, by using both the clock-wise and counter-clockwise spiraling motion. The idea is simple and why not attempt to build your own home-made Water Double Egg Vortex? So, look at your soft-boiled egg timer, expand the concept and apply it to vortexing your water (♦SG203.5.4 What is a Vortex (3) DIY).



← ↑ Double-Egg Vortexer.

You simply invert it to create another vortex.



↑ The Vortex Jug is using a paddle spun by an electric motor in the lid.



← The Vortex Energizer is attached to the incoming water main in your house.

The Water Egg → is a water dispenser made out of terracotta and allowing the natural circulation of water. There is a copper spiral in the lid.



These devices can be obtained from [www.sulis-health.co.uk](http://www.sulis-health.co.uk)



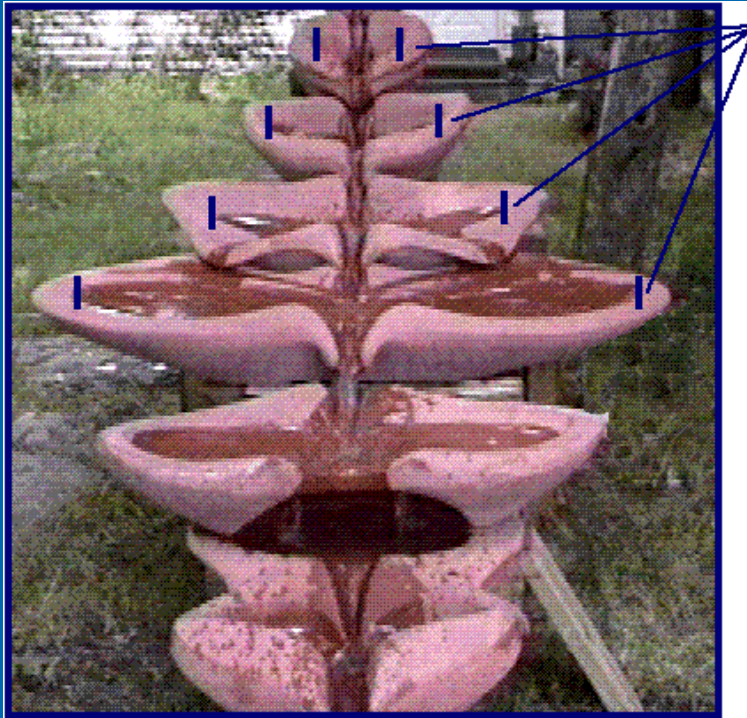

Golden Mean Ratio

## SG203.5.9.5 Vortex Water (5) Flowform Fountains

The Flow-forms are a contemporary development pursuing the goal of Viktor Schauberger: giving back to the water its nobility.

◆SG105.5.5.3 & 4

*"As a forester I was often able to observe how sick and severely wounded animals sought out certain herbs and immersed their wounds in very particular kinds of water. Ultimately it dawned on me that very mysterious powers dwell in water..."*

*The true foundation of all culture is the knowledge and understanding of water...  
Water is the original accumulator which readily absorbs both earthly and cosmic substances and conveys them to the body..."*  
(V. Schauberger)

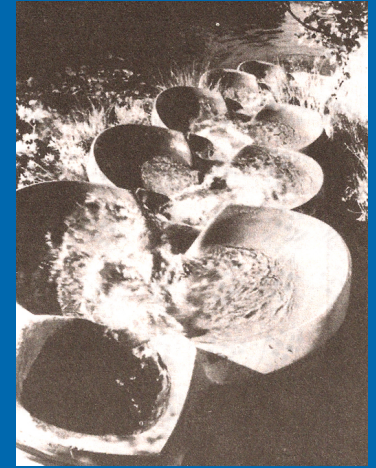

↑ In the Flowform Fountains, the water vortices follow the Golden Spiral/Rectangle geometry.





# SG203.5.9.6. Vortex Water (6) Phi Imploder

Implosion tech breakthrough: the Water Imploder nozzle.

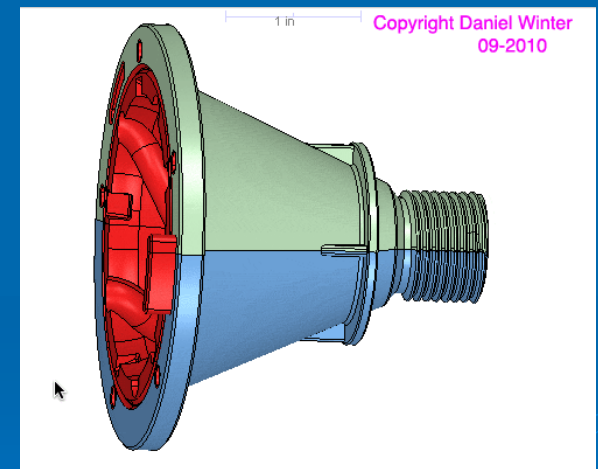
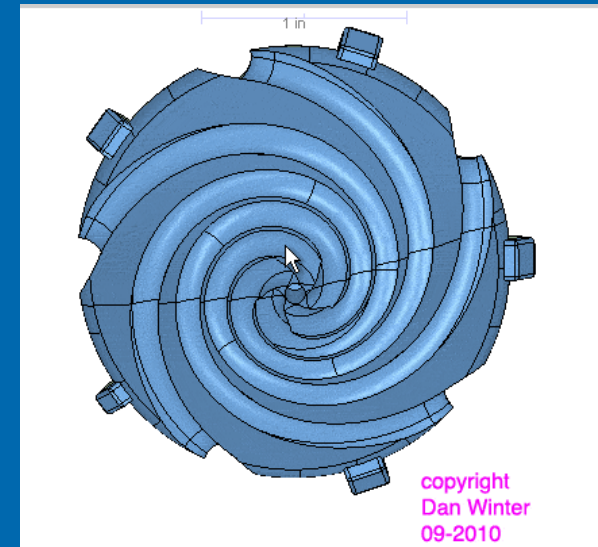
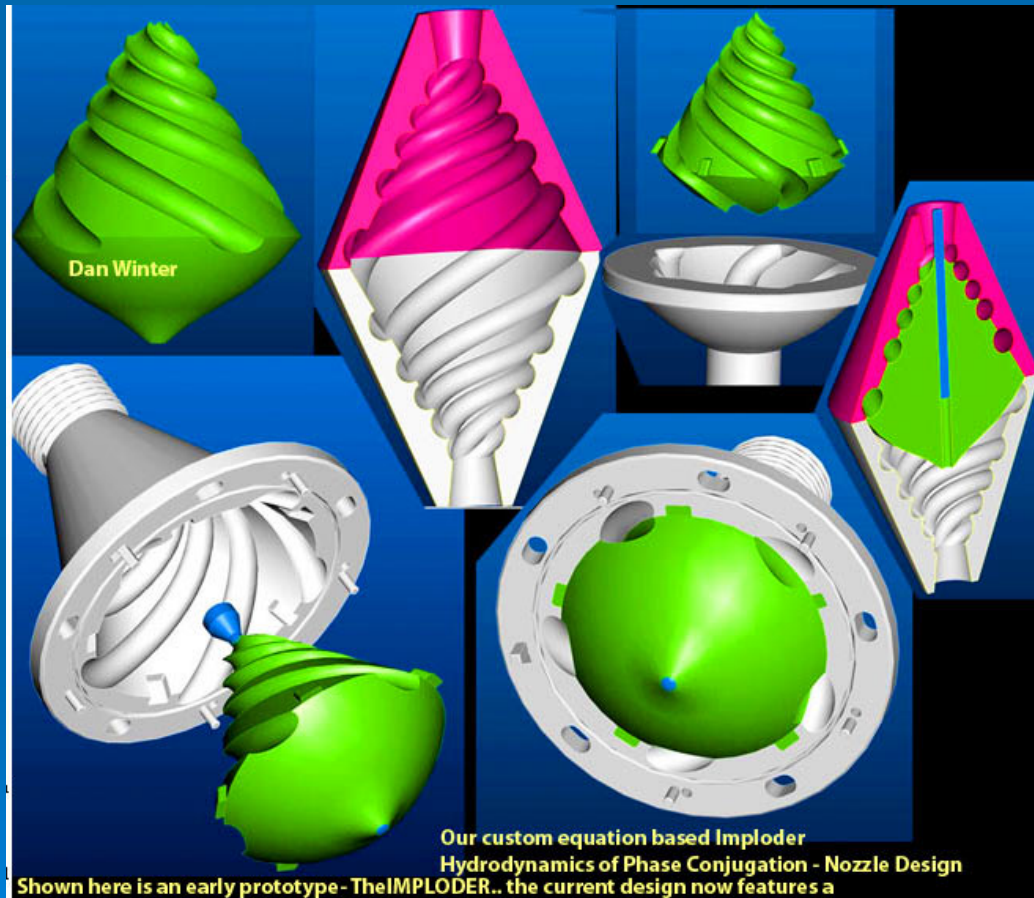

Imploder water treatment device based on the Phi fractal vortex.

[www.fractalfield.com](http://www.fractalfield.com)

# SG203.5.9.7 Vortex Water (7) Energy Plant

The Austrian website <http://www.zotloeterer.com> offers new ideas, prototypes and commercial units for water vortex engineering. It is fitting that these applications appear in the homeland of Viktor Schauberg.

In his website, Austrian engineer Franz Zotlöterer explains about his experiments to regenerate water by natural sustainable methods. Following the model of a free river flow creating vortices behind a stone, Zotlöterer's company produced a rotation tank with a giant single vortex inside. The benefits are numerous:

- increases the water surface area.
- maximizes the velocity of flow on the water surface area.
- disseminates homogeneously the contaminants in the water.
- increases the contact surface of contaminants for microorganisms and water plants.
- aerates the water naturally, because of the high velocity of flow on the water surface area and the increased water surface area, to support the self-purification of water with microorganisms and water plants.
- builds up a peripheral zone of ice in the winter to isolate the center of the vortex.
- concentrates dense water (water at 4°C) in the ring-shaped centre to ensure the survival of microorganisms as long as possible.
- decelerates the flow of water, so it can be used as a active retention pond.
- concentrates rotation energy in the ring-shaped centre and so it can be used for a water power plan.



↑ Rotation vortex tank

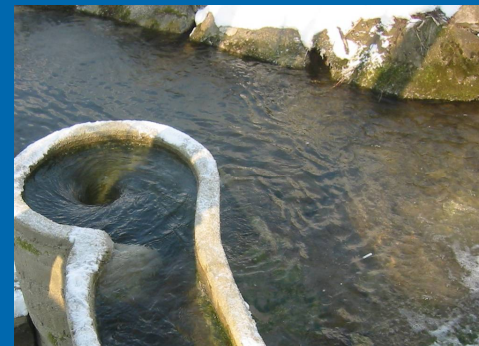

← Vortex tank installed on a regulated river in order to activate its self-regeneration.



↑ The vortex energy plant supplying electricity for the Green School, Bali. [www.greenschool.org](http://www.greenschool.org)

→ In the first year of its operation, this water power plant produced 50.000 kWh of electrical "green" energy for 14 average European households. The prototype plant supplies the public utility network with "green" electricity. The gravitation water vortex power plant is on the millstream in Obergrafendorf (10 kms Southwest from St. Pölten, Austria). It is open to the public.



↑ The water vortex turbine extracts the rotation energy from the gigantic water vortex and powers a generator.



# SG203.5.9.8 Vortex Water (8) Deep Ocean Power

*"Our energy technologists would abandon contemporary methods of generating electricity did they but know that this can be obtained directly from the deep sea by means of the simplest apparatus."*  
 (V. Schauberger)

Schauberger has observed that true springs are created by the center-stratum of the groundwater table (4°C oxygen-starved water) that is squeezed and partially lifted to the highest mountain peak, in its quest for oxygen. The same principle is used in Schauberger's brilliant invention of deep ocean energy generation. This is not wave or tidal energy as currently developed: it is an application of implosion and the natural power of levity. A very timely and low-cost technology to develop. Details in the book *Living Energies* by Callum Coats or here: [www.frank.germano.com/oceanpower.htm](http://www.frank.germano.com/oceanpower.htm)

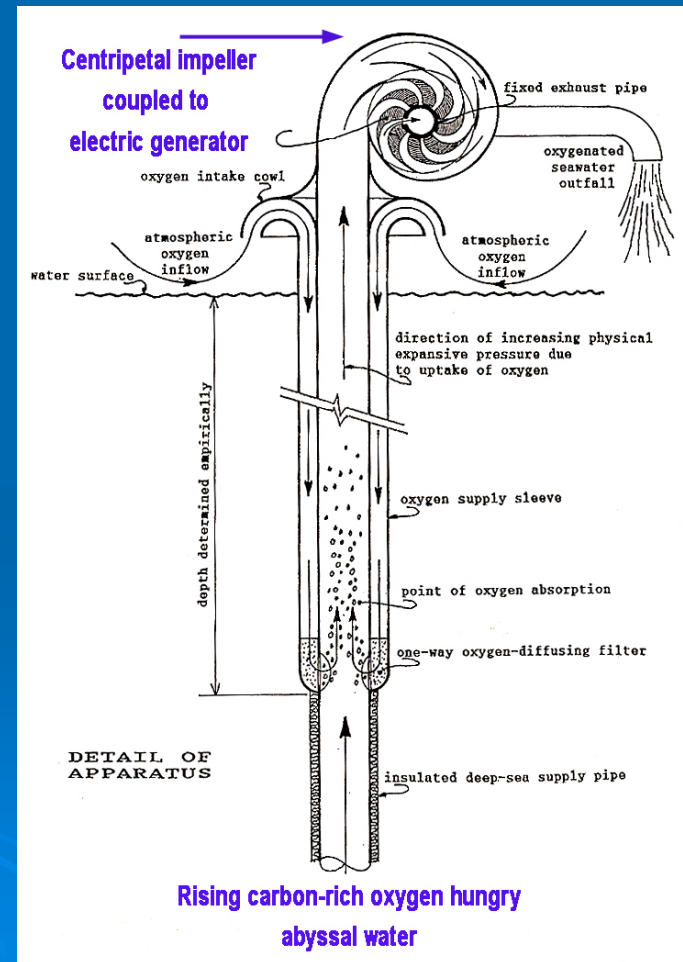
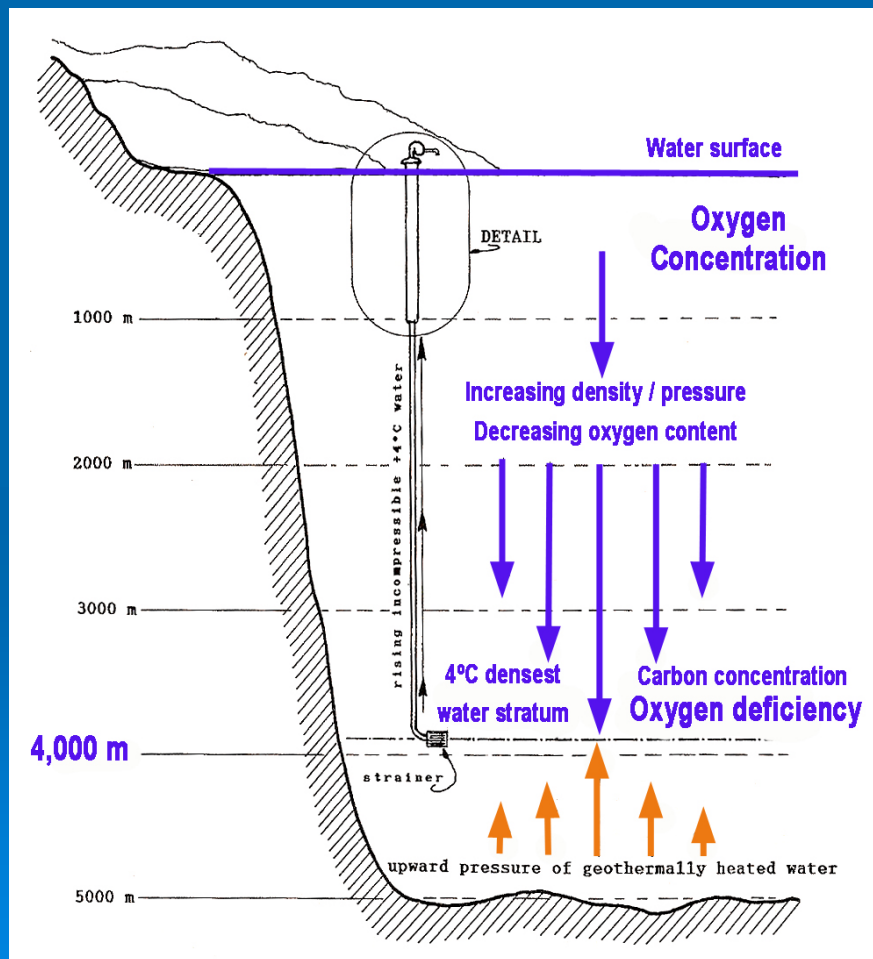



**In Vortex Implosion Design: Power Out derives from Charge Acceleration thru C (light speed)**

– The water is piezoelectrically ‘doped’.

Port-U-Grail

Optimising the Whole by measuring the Blue aura with HeartTuner

Fast spinning Vortex for picking up an Energy charge

Egg-shape already creates a charge difference

Optimising Shape container  
Side view: 2 golden mean spirals

Most magical water with Colloidal content, a Trace mineral that makes the water piezo-electric.

Ceramic or Glass

super smooth polished

Impeller: several plates 2" or 3" across, Tesla Turbine, Turning clockwise.

50.000 rpm DC motor

Golden band for picking up electrostatic charge

Water motion at edge of container

Vortex Implosion contactPoint for picking up electric charge

Transformer

? Volts OUT

V IN

↑ New generation of Implosion vortex technology.  
([www.goldenmean.info](http://www.goldenmean.info))

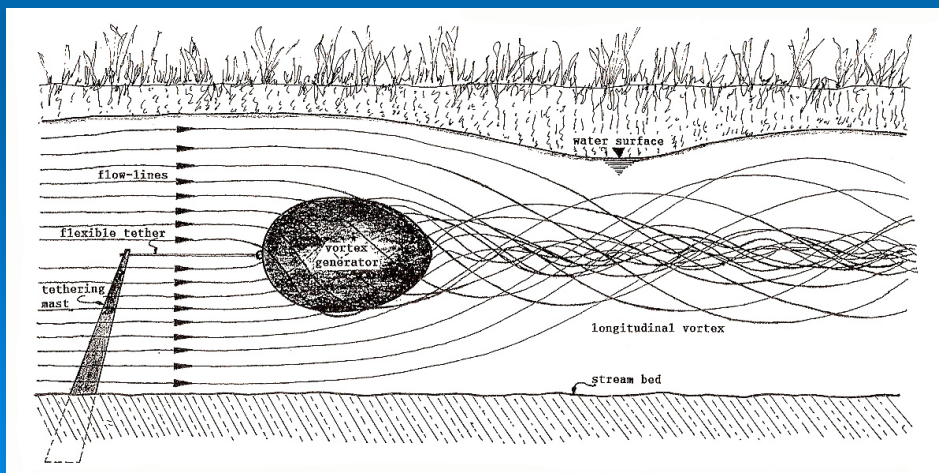

## SG203.5.10.1 Egg-Shape Power (1)

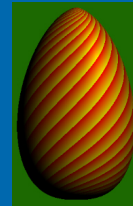

Viktor Schauberger abandoned the Euclidian model of straight line and circle. All the functional geometries of his prototype machines are complex curvilinear surfaces using the spirals, sinuosities and curves of the open forms found in nature. The egg-shapes and spirals that he used produced life-affirming energies capable of stabilizing, enhancing and rehabilitating natural processes & harmony.

Note: recall how, in Projective Geometry, one of the archetypal forms of space is the EGG with its generative spirals.

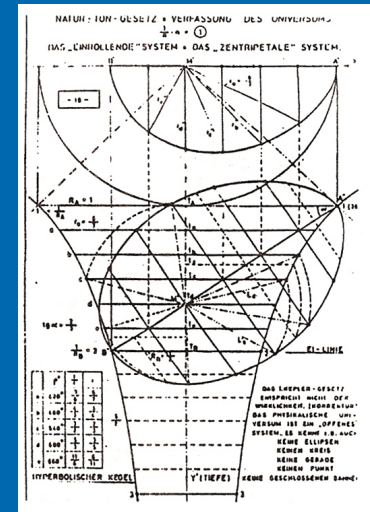

↑ Egg geometry design from Schauberger's papers.

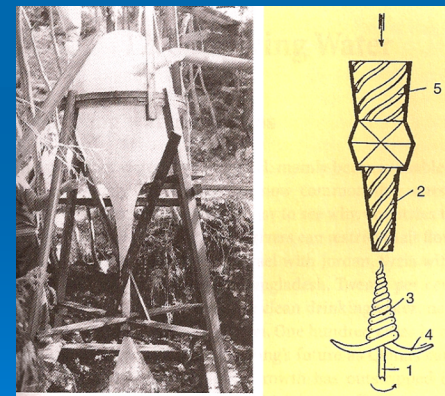

← Experimental egg-shaped vessel (left) and hyperbolic cone with spiraled nozzles (right) for hydro-electric power. Birnberg, Austria. (Alick Bartholomew. *Hidden Nature*. 2003)

← An egg-shape "Vortex Generator" for the creation of longitudinal vortices in streams. (Callum Coats. *Living Energies*. 1996)

## SG203.5.10.2 Egg-Shape Power (2)

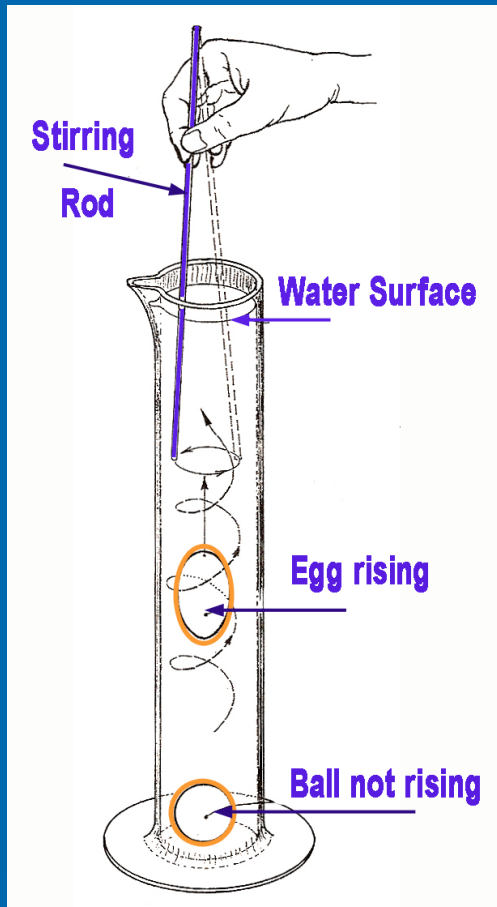

The Egg-shape experiment

**Step #1.** Put an egg in a tall jar filled with water. Using rod, stir the water. Soon the egg will rise and stay up, even with reduced stirring.

**Step #2.** Fill a ping-pong ball with saline solution to match the weight of the egg. Put the ball in the jar. Stir as before. The ball does not have a tendency to rise.

(From: Callum Coats. *Living Energies*.)

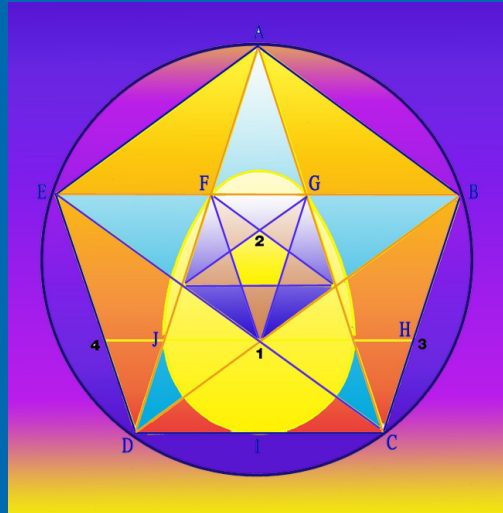

↑ The Cosmic Egg in the pentagon/Pentagram

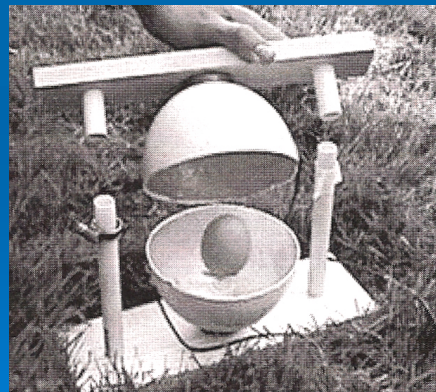

↑ Experimental set up by Dan Winter to measure life force potential. The egg is an ostrich egg cut in half and coated with gold.

[www.goldenmean.info](http://www.goldenmean.info)

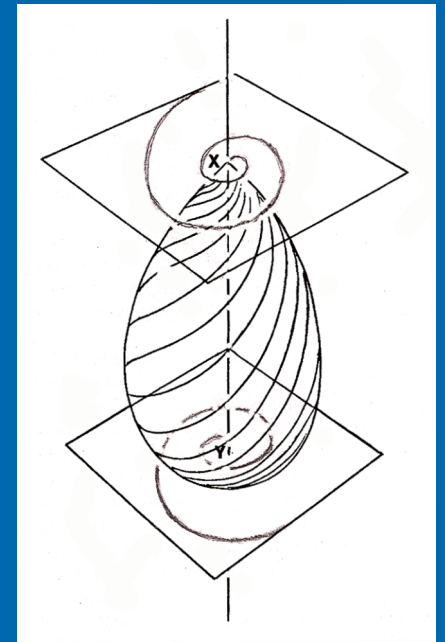

↑ Projective geometry of the primary egg shape of space. (Edwards)

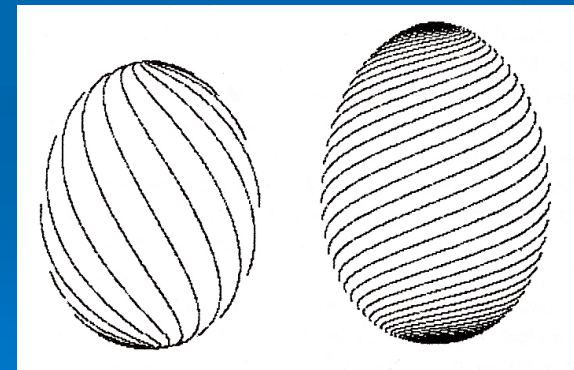

↑ Path curves models of duck eggs.



## SG203.5.11 Spiral Agriculture - Bio-Plough

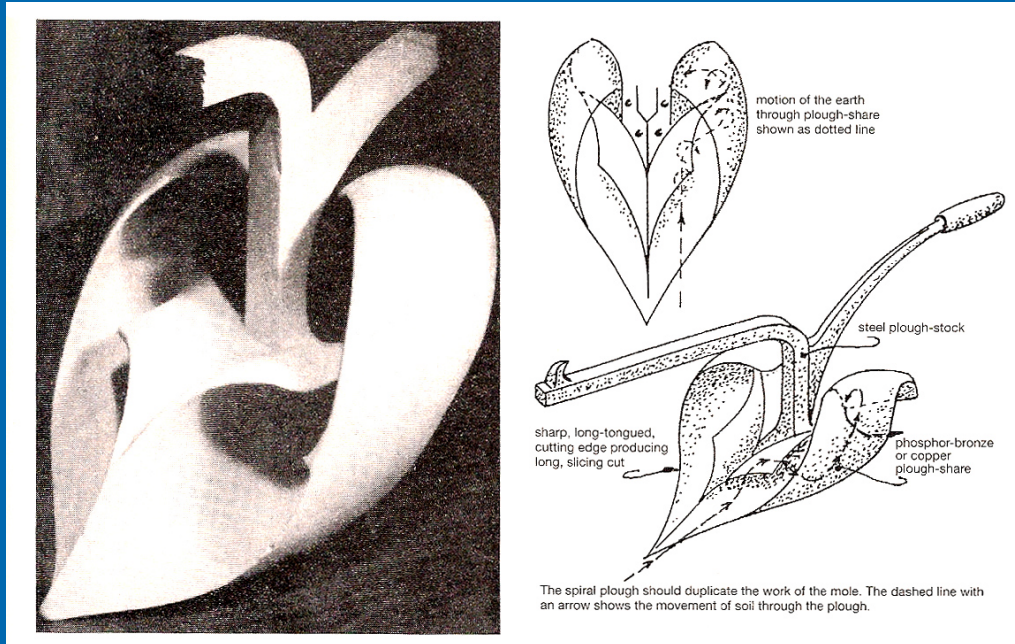

### ↑ The Bio-Plough developed by Schauberger in 1948.

*"To reduce the damage to the soil capillaries to a minimum, instead of the pressure-wave forming and shearing crush-cut of the conventional ploughshare, the Bio-Plough's blade is designed so as to create a long slicing cut before the soil is involuted through the CENTRIPETAL action of the curving swan-like wings... The soil glides through between the curved foils and gently rotates left and right, in a infinity-sign motion. The Bio-Plough is emulating the burrowing action of the mole... These experiments also clearly established that the soil should never be worked with naked iron or steel, but only with implements made of wood, copper or copper alloys."*

(Callum Coats. Living Energies.)

Note #1: Due to the pressure of the fertilizing industry, the Bio-Plough was never implemented in Austria. Who is going to globalize the timely Bio-Plough, more than 60 years later?

Note #2: copper garden tools are manufactured in Austria and England and have proven to be much superior in handling the soil and preventing pests.

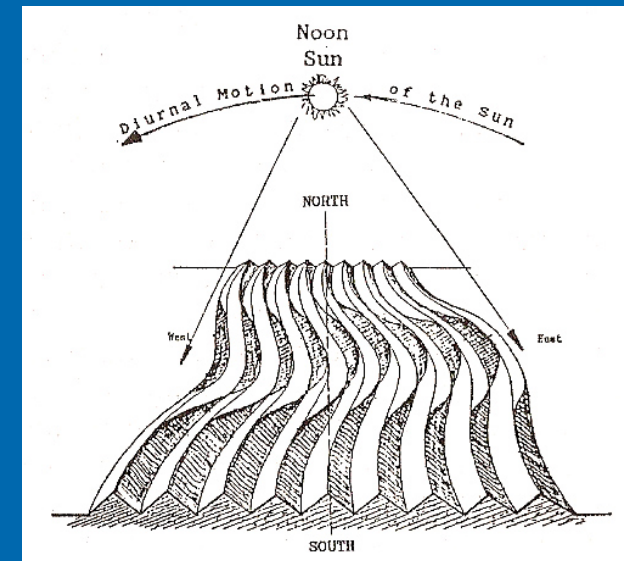

### ↑ Sinusoidal Plowing

From his observations, Schauberger showed that, instead of plowing in straight lines in any direction, the furrows should be sinuous, curving first one way and then the other, and oriented as far as possible in a North-South direction.

This way, no portion of the soil receives uninterrupted solar radiation and the plants enjoy an even distribution of both light and shade as the day progresses.



# SG203.5.12.1 Implosion Technology (1) Past & Future

Schauberger's pioneering work has shown that current technology, based on explosion and degenerative breakdown, is ignoring and missing the better half of nature's way of creating energy and motion: implosion. Bio-mimicking nature by using the principle of implosion as the basis of our technology holds a immense promise for full energy efficiency, sustainability of natural resources and a cooperative partnership with water, air, earth and the formative forces of the higher-dimensional zero-field or vacuum of space, traditionally known as the *ether* (or *aether*).

In the words of Frank Germano, President of Global Energies Technologies: *"We use the wrong type of motion to accomplish our work! There exist two forms of motion within Nature - one that breaks down and the other that builds up and refines. Both work in a rhythmical balanced, interchanging cooperation with one another. The form of movement which creates, develops, purifies and grows is the HYPERBOLIC SPIRAL which externally is centripetal and internally moves along the longitudinal axis.*

*The destructive and dissolving form of movement is centrifugal and moves towards the periphery. With centrifugal movement mediums are first weakened, then dissolved and broken down. This is the way Nature disintegrates her complexes.*

*The centripetal movement is synchronous with falling temperature, contraction and concentration. The centrifugal is synchronous with rising temperature, heat, extension, expansion and explosion. It should be apparent that our present technology's poor results are because of Nature's resistance to man's single-minded pursuit of explosion, destruction and decomposition. The over heating problems of our machines, air resistance, temperature and sound barriers are evidence that man is on the wrong destructive path in technological pursuits."* ([www.frank.germano.com](http://www.frank.germano.com))

Schauberger's insights show that there is more energy available from water flowing into a spiral vortex than from free-fall of comparable distance, as in the hydro-electric power obtained from gravity (and ecologically disastrous dams).

Schauberger engaged his full creativity into designing appliances and technologies using nature's methods of attunement & resonance and therefore able of producing vastly more power than old paradigm technologies forcing man's will on nature. Schauburger was on a mission: *"I must furnish those who would protect or save life with an energy source which produces energy so cheaply that nuclear fission would not only be uneconomical, but ridiculous. This is the task I have set myself in the little time I have left."*

## Some of Schauburger's implosion technologies:

- River Flumes & Hydro-dams
- Suction Turbine
- Suction Propeller
- Bio-Tech Submarine
- Propellerless Drive Fish Motor
- Levity Disks
- Air Turbine
- Ocean Power System
- Home Power Generator
- Implosion power plant
- Water treatment through vortex funnels
- Centripetal Pumps
- Klimator Air Conditioning
- Egg-shape storage
- Vortexing Water pipes

*"Implosion is no invention in the conventional sense, but rather the renaissance of ancient knowledge, lost over the course of time."*

(V. Schauburger.)

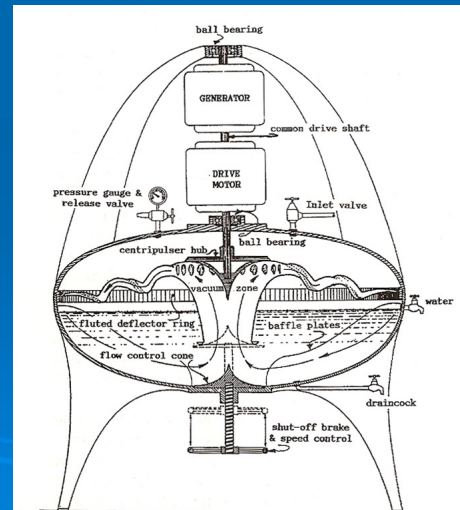

**Tornado Home-Power Generator**

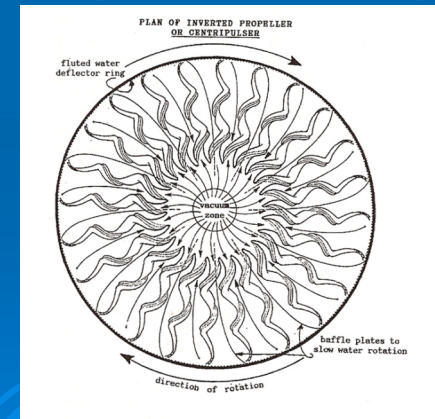

↑ Home-Power Generator.  
Detail: Inverted Propeller  
("Centri-pulser")

# SG203.5.12.2 Implosion Technology (2) World-wide Research

In June of 2001, Callum Coats sent a global call to do a timely Report on Viktor Schauberger and "Implosion technology". A number of planned steps are being made for the development of Implosion technology: educating the public and the scientists, networking worldwide with inventors & researchers and launching practical R & D projects. This initiative contains will hopefully lead to the development and implementation of some of Schauberger's devices.

Frank Germano, former aerospace engineer, musician, inventor of Tesla-type technologies and founding member of International Turbine And Power, LLC, is leading the team at "Global Energy Technologies, Inc." to investigate and implement implosion-based technologies, as well as to explore the potential of large-scale commercial utilization of the devices. Several units have been designed and the necessary funding for this project is currently being located. Individuals and groups of people are actively pursuing this area of interest world wide. Franks website is a wealth of inspiring information to start research and development and to re-build some of the devices designed and made by Viktor Schauberger, which applied Implosion technology aided by diamagnetism and anti-gravity.



Implosion tech & Schauberger Report [//www.frank.germano](http://www.frank.germano)

Study and experimentation has continued after Schauberger's death, especially during the last 20 years. A substantial amount of information exists in his own writing, in books, articles, reports and historical accounts, including what took place during and after the Second World War. The motivation for this Implosion Team work is to get implosion technology and some of Viktor Schauberger's other inventions established and applied in our world. The many life threatening environmental deadlocks of our present time, are a dire legacy of the type of technology we currently employ, using fossil and nuclear fuels.

## Quotes from the Implosion Report (Frank Germano):

- *Finding scientific, practical, and sustainable solutions has now become a matter of survival, for us and for many plant and animal species, in the short term. Another motivation is my determination to help break the 'stalemate' situation which has held this Implosion technology from being developed for over half a century, in spite of today's environmental crises. The development of scientific knowledge cannot be halted indefinitely, but for a relative short period of time.*
- *This technology utilizes the levitational properties of water and uses diamagnetism, as raw energy, present within a biological vacuum. This technology copies creative processes, therefore it yields positive and sustainable results in excess. (Some of Schauberger's inventions were 'free-excess energy' devices.)*
- *In Implosion technology, two types of motion are combined or simultaneously taking place - Centrifugence: which gives pressure, friction, temperature rise and biological deterioration. - Centripetence: giving suction, temperature drop and biological improvement.*
- *The working mechanism: the double cycloid spiral curve (as in a vortex) concentrates, contracts and compacts the water. This contraction cools and this cooling creates a vacuum. This vacuum augments suction, the whole process generates a diamagnetic force.*
- *Compacting physical matter to point beyond which it "dissolves" into its energetic form and thus allowing it to return into the physical, can be achieved artificially or mechanically.*

## A world-wide Team Effort:

The following inventors/researchers have duplicated some of Schauberger's work:

- USA - Frank Germano. Has begun CAD work and renderings of the Schauberger implosion devices.
- Austria - Educational work at the KPS ("Kepler Pythagoras School") Schauberger estate.
- Sweden - R & D on water flow phenomena.
- France - J. L. Naudin ([JNL Labs](#))
- Australia - R & D on prototype devices.
- Robert (James) Bailey
- Russia - Dr. Evgeni Sorokodum, PhD ([Vortex Oscillation Technologies, LTD](#)).
- Germany - Alfred Evert, PhD (of [Evert Fluid-Tech, Inc.](#))
- Germany - Educational & research work.
- USA, Texas - Kim Zorzi ([Ultra-Light America](#)).
- USA - Germano-Korzi "Spiral-Vortex Generator-Turbine".
- USA - Prof. Robert Patterson ([Ancient Gravities](#)). Inventor of the "Ram Wing" - a truly revolutionary wing designed with Schauberger-based principles.

## SG203.5.13.1 Implosion Applications (1) The Trout Motor

Viktor Schaubberger derived his idea for a submarine "Trout" motor from the observation of fish, especially the trout which can stand motionless in a flowing stream, just by taking water in and out.

This process, to Schaubberger's understanding, has two functions: first it creates a vacuum in front of the mouth into which the fish gets sucked, and at the same time provides food, as the water contains all that the fish needs. While the food goes into the digestive system, the water is forced through the fan-like structure of the gills, which not only absorb the oxygen needed, but also push the water backwards. This specially compressed water does not mingle right away with the rest, it glides along the conical body like a wedge and shoves it forward. In addition, on the scales it forms little whirls which enhance the push further.

This invention of the spiral-vortex propulsion system, if properly applied, will not only increase speed, but also reduce fuel consumption to a minimum!

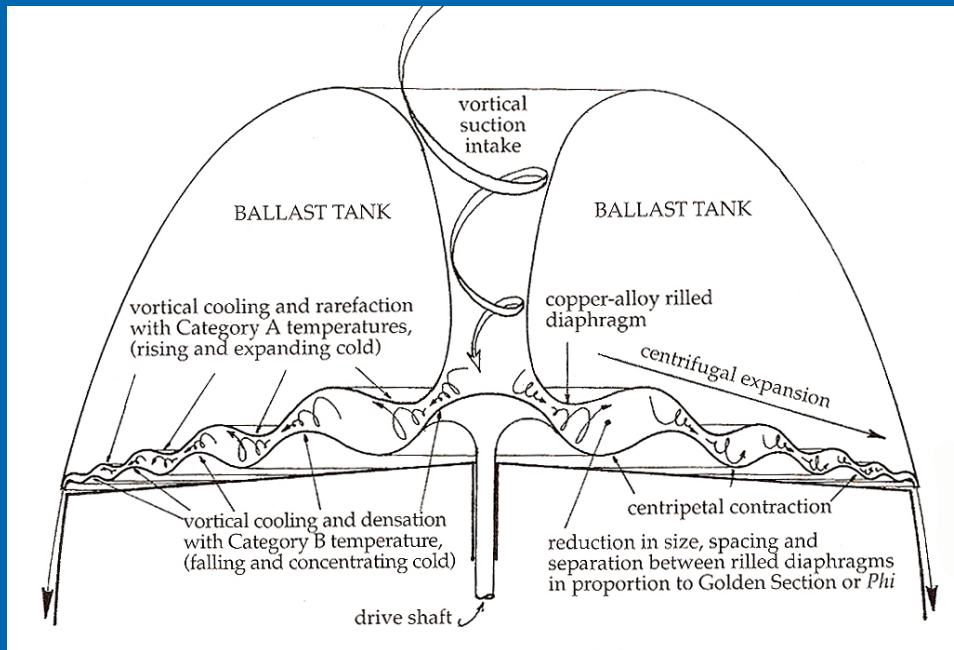

↑ Detail of the vortex propulsion system.

Note the use of Phi ratio in the proportions of the rilled diaphragms.

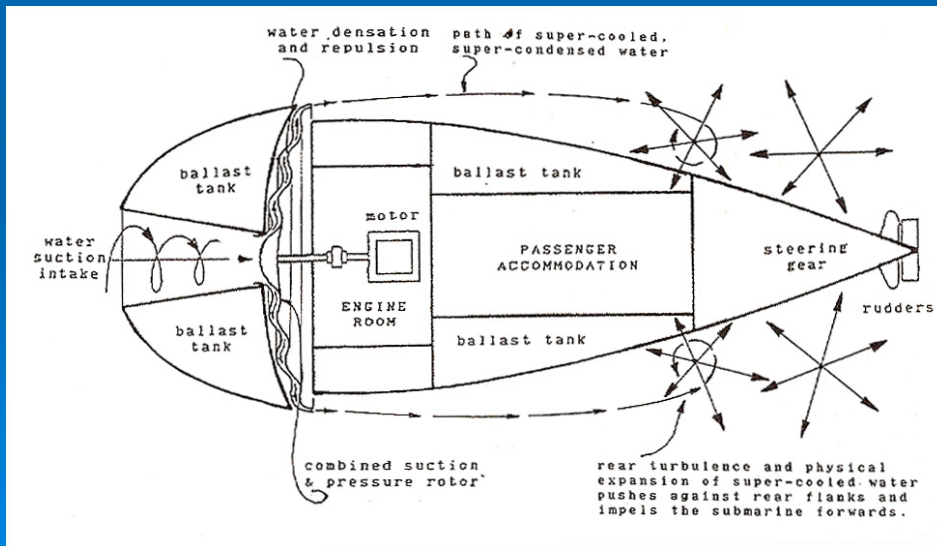

← A draft of the Vortex Submarine, as prepared by Walter Schaubberger, Viktor's son.

The "Trout submarine" has a moveable bow, which gives the boat the flexibility fish have. The conical and rifled water-intake permits a variable step-up, creating a strong torque on the water, which, after entering the implosion turbine, will be intensified to such a pitch, that now its recoil (resonance) is driving it instead of the motor, as bio-technical applications always have a pull and push action. The turbine consists of tapered-down pipes with inside rifling which are bent into spirals.

Frank Germano comments: "The Vortex Propulsion System is not a question of time, rather the will to use it, as it already exists, giving us a chance to move on water, under it and in the air using only a fraction of the energy we use today!" ([www.frank.germano.com](http://www.frank.germano.com))



## SG203.5.13.2 Implosion Applications (2) "Trout" Engineering 1

Viktor Schauberger revolutionary development of the Trout Turbine has been "modernized". Global Energy Technologies has come up with the Bio-Technical Submarine, Biosphere Dirigible and the Bio-Technical Airship. All crafts operate on the same principles set forth in Viktor's patent - with the exception of using a Tesla Bladeless Disk system as the propulsion. If research and development were continued, these crafts could be built today with existing technology.

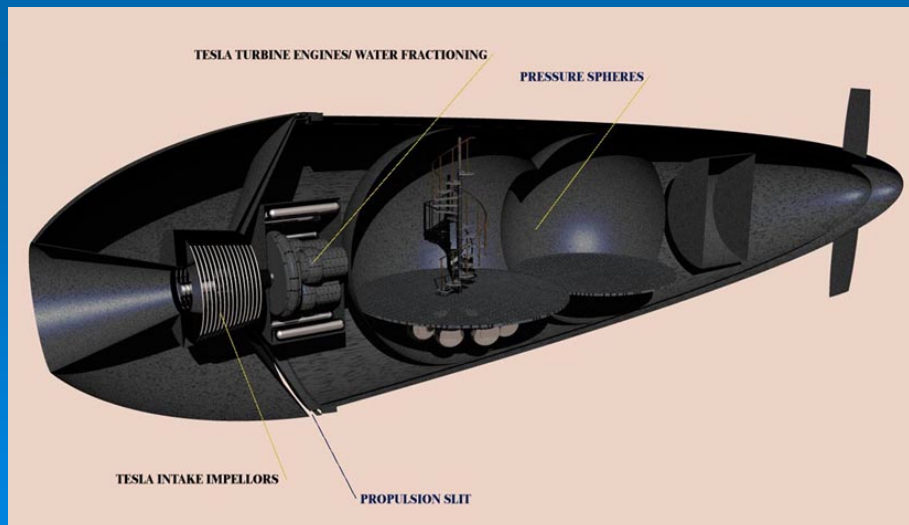
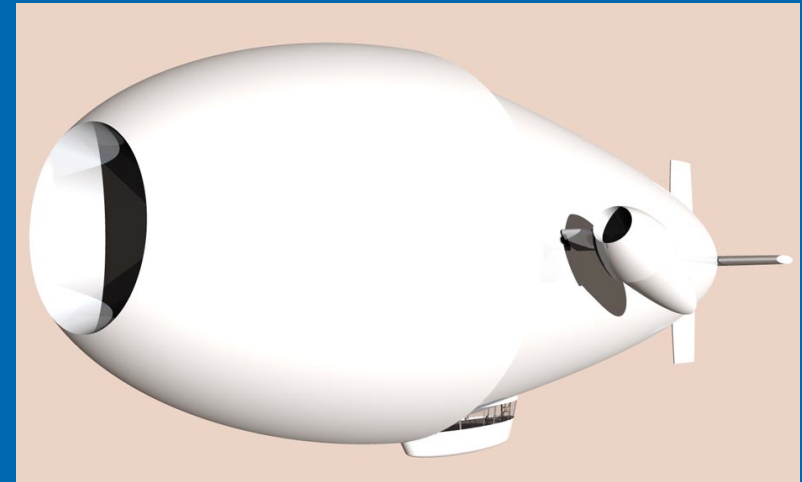
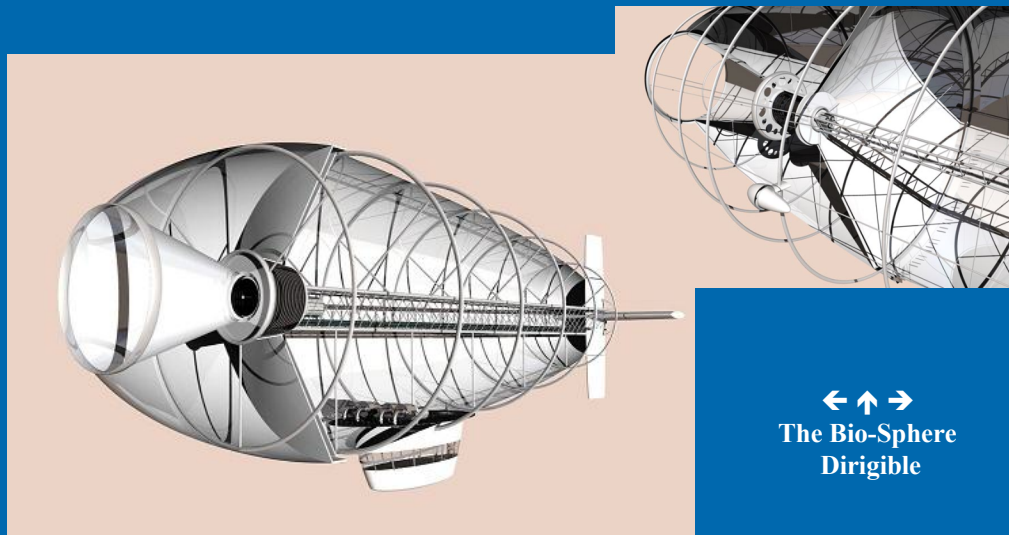

[//www.frank.germano.com/airship.htm](http://www.frank.germano.com/airship.htm)

← The Bio-Technical Submarine.

This new type of submersible vessel would have a sound signature unlike anything previously built, likely mimicking that of a large whale. It would definitely be running more "silent" than anything with a conventional screw propeller for propulsion.

## SG203.5.13.3 Implosion Applications (3) "Trout" Engineering 2

The Bio-Technical Airship by Global Energy Technologies

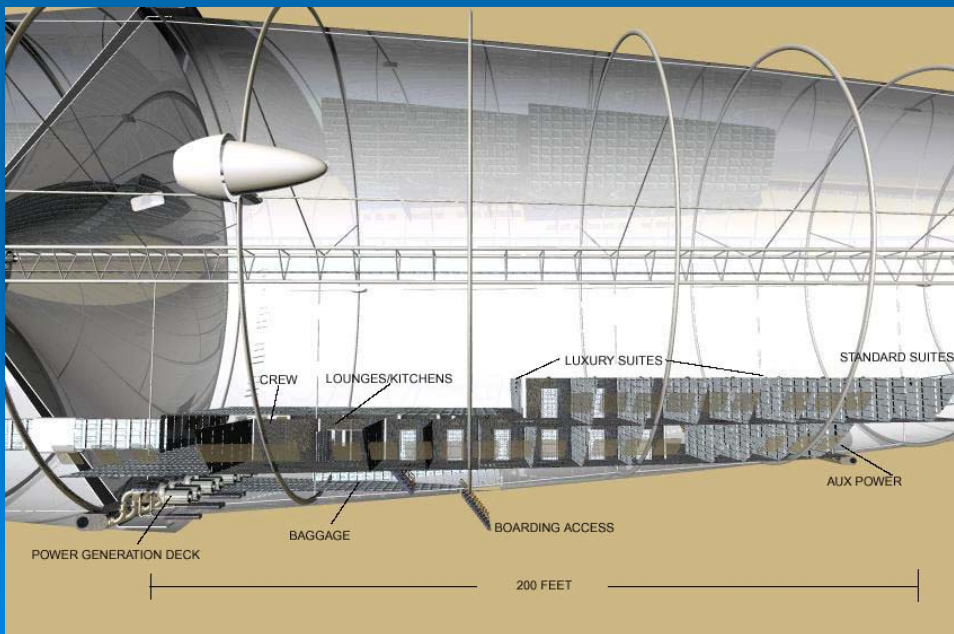
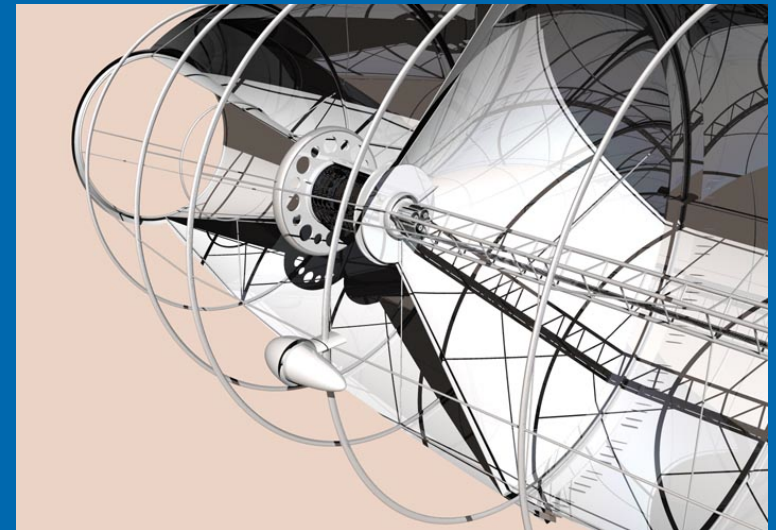
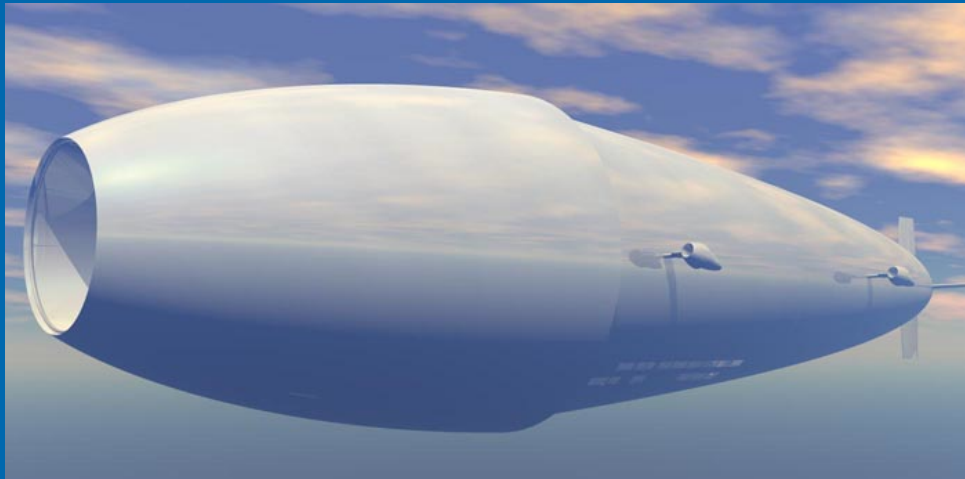

Schauberg & Tesla hybrid vortex propulsion system,  
internal vortex accelerated thrusters,  
outboard mounted control pods,  
framed internal super structure.  
571 feet length. 145 feet diameter.

[//www.frank.germano.com/airship.htm](http://www.frank.germano.com/airship.htm)



# SG203.5.14.1 Implosion Power (1) The Repulsine (1)

## The story of Schauberger's "Saucers" (1)

In 1940, following on his invention of the Trout Motor, Schauberger began construction of the *Repulsine* discoid machine in Vienna, with help of the Kertl company. This prototype was intended to test implosion propulsion and potential levitational flight. This invention was patented on March 4, 1940, in Austria, under #146,141.

The patent is entitled "*Processes and Equipment for the Atomic Transformation of Droppable Liquids or Gaseous Substances*" and reads:

*"It is known that dissociation and recombination, therefore the rearrangement of the atoms, can be effected in the substrate with the aid of catalytic processes. In this regard it has been observed that these processes take place in a characteristic cycle or oscillating rhythm until a new state of equilibrium is established.*

*The process for the atomic transformation of liquid or gaseous bodies associated with this invention takes this rhythmical tendency during the course of such processes into account from the very beginning. Namely, the aforesaid substances will be subjected to an increasingly rapid flow-motion, during which these substances will be exposed to alternating strong suctional and pressural forces, which results in significant changes to their surface tension."*

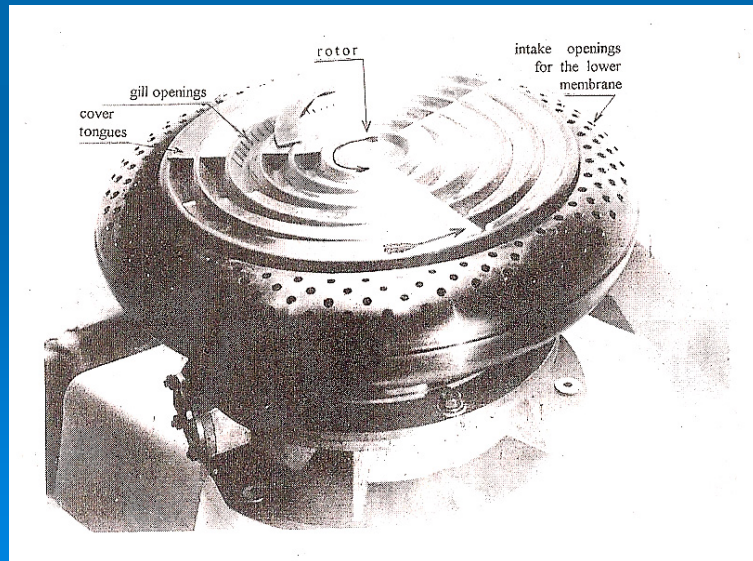

← A reconstructed model of the Repulsine. (after the 1940 patent).

Diagram #1 → (1940 patent)

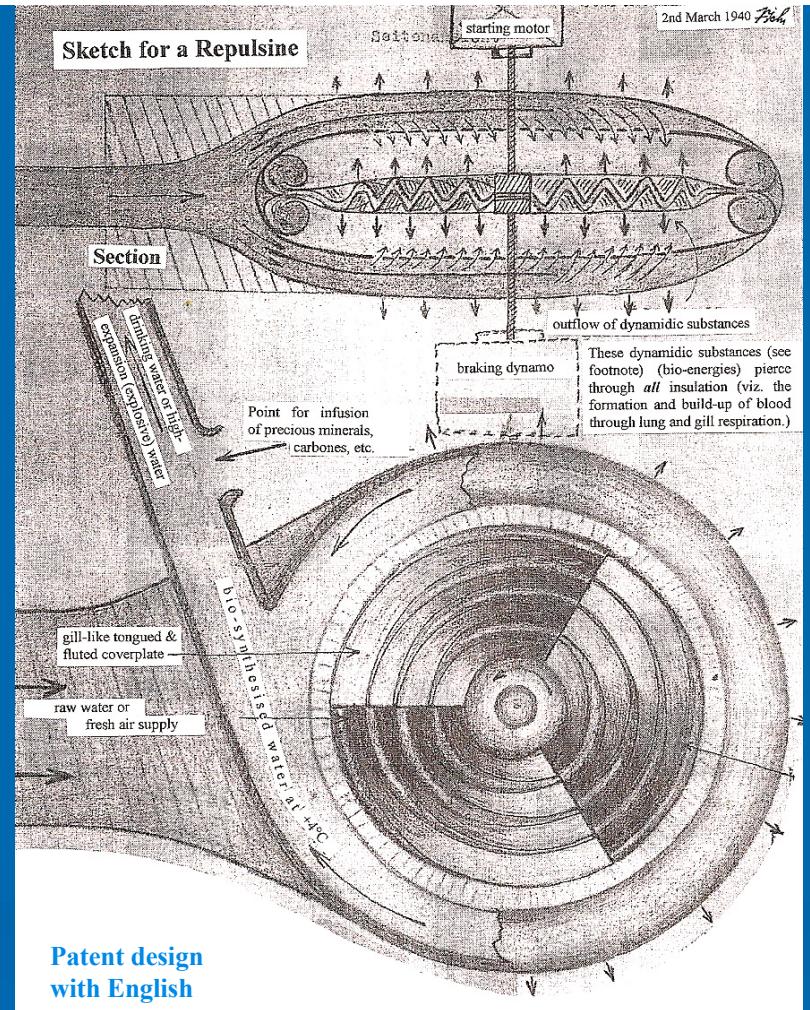

Patent design with English Translation.

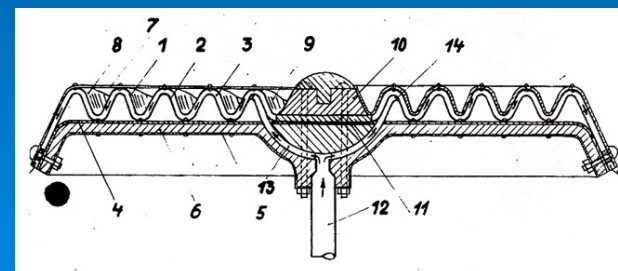



# SG203.5.14.2 Implosion Power (2) The Repulsine (2)

An informative Russian website ([//evg-ars.narod.ru](http://evg-ars.narod.ru)) has one page in English about Schauberger's Repulsine device. The following diagrams & animations illustrate the understanding of the Repulsine as a "tornado-making" machine. We quote some of the explanations given on this page. Thank you EVG-ARS!

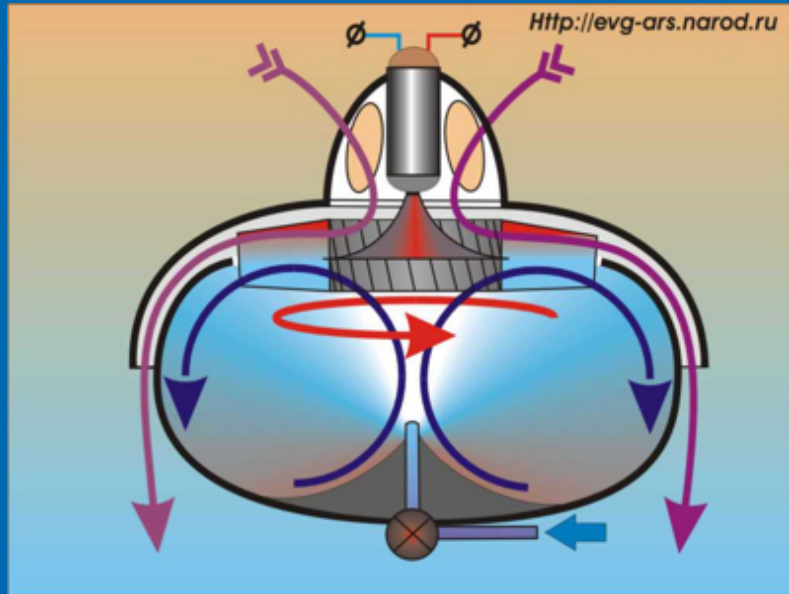

Approximate → demonstration of the internal arrangement of the Repulsine machine.

"Schauberger created the ideal conditions for appearance of a group of mini-tornados and of a central tornado, which is the motive force of the device. At the first stage by means of the wheel, the air swirls around the axis of the electric motor. Due to the centrifugal force the same air is thrown to the periphery, passes through the 'corkscrews' of the wheel and gains rotation down the axis of each 'corkscrew'. The air simultaneously swirls around 2 axes of rotation.

Thus the wheel creates 24 mini-tornados. The upper part of the device looks like a copper basin. Turning round the internal surface of the upper part of the device, the mini-tornados move away to the internal cone of the device and forward to the outlet.

Indeed, such a process is 'implosion' (as opposed to ordinary explosion) since the matter does not move from the center but on the contrary, tends to constrict into the common point (to the top of the vortex). The rotating mini-vortices, which compose a tornado, are attracted to each other and tend to move to the basic center of rotation."

([//evg-ars.narod.ru](http://evg-ars.narod.ru))

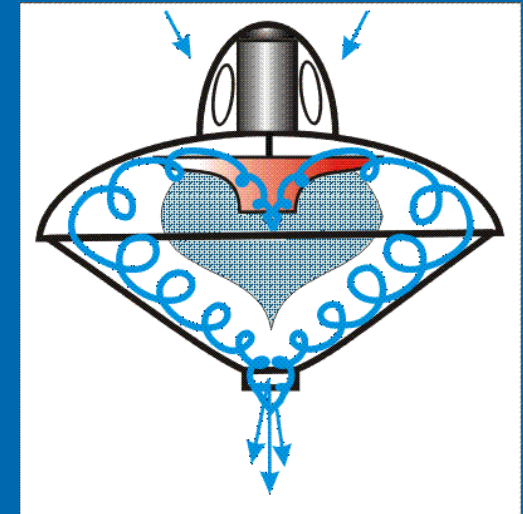

↑ A power plant based on the tornado-vortex principle.

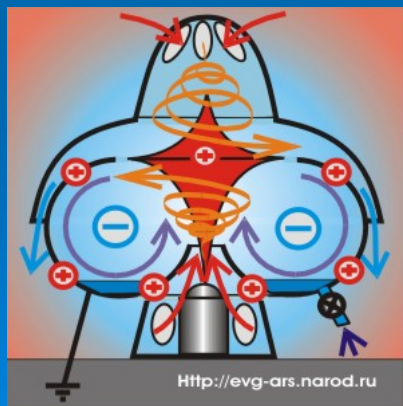

↑ → The principle of the tornado.

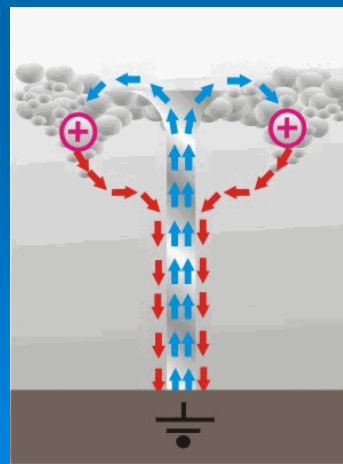

# SG203.5.15.1 Implosion for Levity

## (1) Levity Disks 1

### The story of Schauberger's "Saucers" (2)

Unfortunately for Schauberger, he was an Austrian caught up in the territorial expansion of the Nazi regime and his work came to the attention of Hitler himself. As a result, at the peak of his creativity, he was forced (under threat of being hanged) to work for the Germans until the end of WWII. Under orders from Himmler he was to carry out R & D at Mauthausen concentration camp where he worked, under special dispensations, with twenty to thirty prisoner engineers on secret projects centered on "levity disks". In 1944 he and his engineers were moved, again under the direct orders of the SS, to Leonstein in Austria.

At the end of the war, all the machines and documents were either destroyed by the SS or pounced upon by American and Russian special intelligence units.

It is established that improved models of the Repulsine were built. One of them, according to Callum Coats, generated such a powerful levitational force that *"it sheared the six 1/4 inch diameter anchor bolts and shot upwards to smash against the roof of the hangar."* And reports indicate that several similar devices were built on a larger scale. For instance the "flying disk" launched in Prague January 19th, 1945, which rose to an altitude of 15,000 meters in 3 minutes and attained a forward speed of 2,200 km/h, is thought to be a development of the Schauberger Repulsine. Later, Schauberger wrote: *"I only first heard of this event after the war through one of the technicians who had worked with me"*. And in a letter dated August 2nd, 1956, Schauberger commented: *"The machine was supposed to have been destroyed just before the end of the war on Keitel's (the Commander of the German Armed Forces) orders"*.

As doomsday was impending for the Third Reich, SS scientists worked frantically to develop flying machines that would be such innovative and powerful "secret weapons" that the tide of history could be turned around: among them the electro-gravitic *Haunebu* flying disks. It is likely that the Schauberger liquid vortex type propulsion, with its up-current of axially-pulsed air, was combined with "flying circles" designs, such as conceived by Schriever back in 1941 and later by Miethe. It is speculated that Miethe's final design that flew in Breslau in 1944 was an enlarged manned Repulsine-type craft...

As a final note: in 1947, the first "UFO" was officially spotted by Kenneth Arnold.

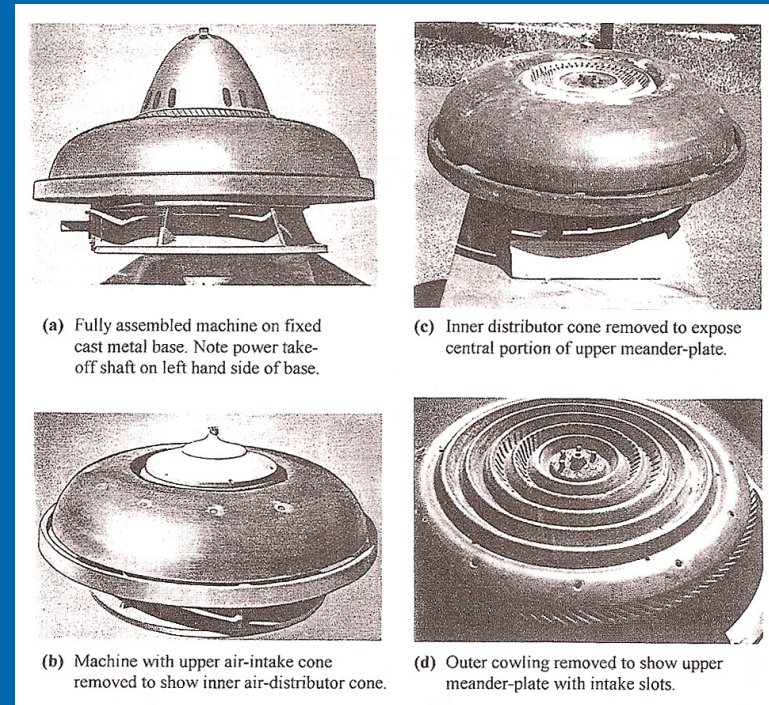

↑ Small scale "Repulsine". Early prototype.

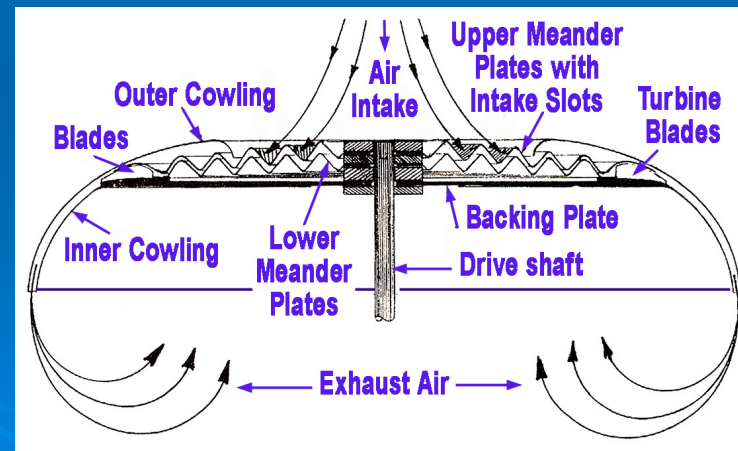

↑ Cross-section through the Repulsine.



# SG203.5.15.2 Implosion for Levity

## (2) Levity Disks 2

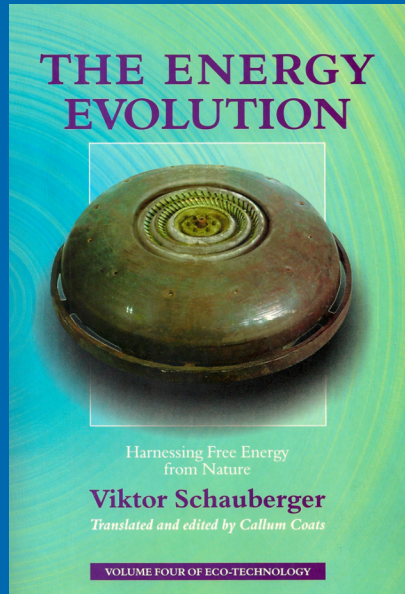

In 1936, while describing one of his implosive machines, Schauberger joyfully declared: *"In the whole machine, there is no straight line and no circle."*

Callum Coats comments: *"By this, he meant that the overall design and shape of his devices were founded on completely different parameters than those of current design. The effective functional surfaces and forms of these machines incorporate the swirling spirals and sinuosities, the open elements of hyperbolic geometry so prevalent in nature. By incorporating such organic spiral configurations and egg-shapes in his devices, energies are produced that are life-affirming in lieu of those generated by conventional machines that are inexorably destroying life."*

(The Energy Evolution).

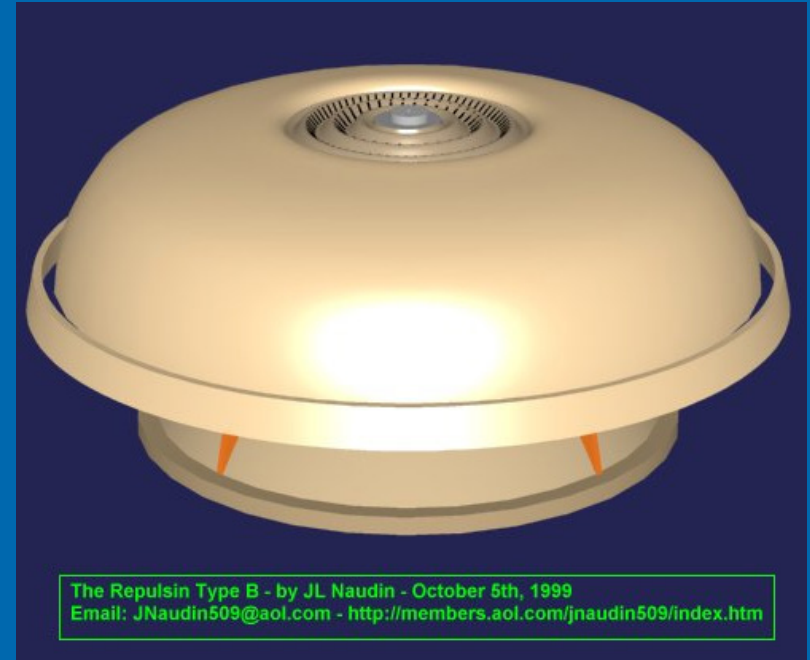

The Repulsin Type B - by J.L. Naudin - October 5th, 1999  
Email: JNaudin509@aol.com - <http://members.aol.com/jnaudin509/index.htm>

↑ J.L. Naudin's reworking of the Schauberger "saucer", the Repulsine.

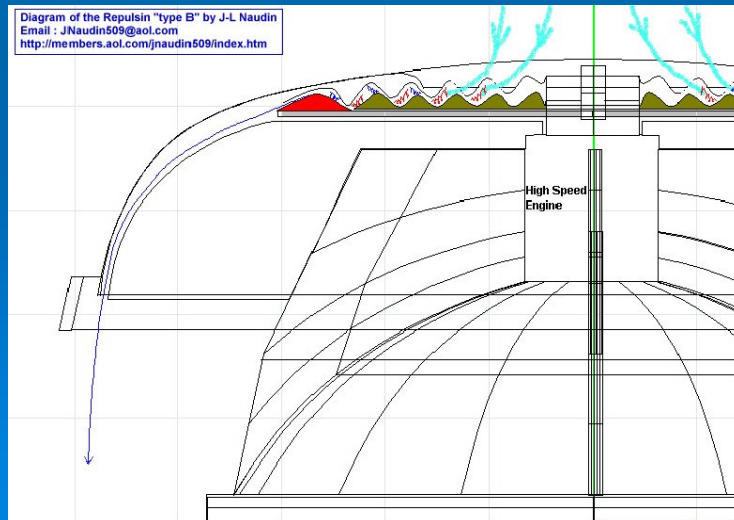

← Diagram by Naudin.

The upper membrane is fixed and the lower rotates at high speed. On the edge rim there are special shaped blades (boomerang shaped blades). There are 120 blades (3 degrees spaced).

When the air exits from the turbine at high speed, it follows the curved shape of the hull and increases also its speed while the gap decreases along its path.

*"The implosion motor uses suction forces. So there is no heat or sound barrier, because friction is almost entirely lacking. The air flows through the rotating air inlets placed in the middle and follows the gap between the double membranes (with the wave pattern): this creates a spiral contraction of the flowing medium and creates a vacuum which increases the suction pull. The enhanced vortex turbine uses two flat membranes with concentric rills on it. A wave pattern has been set on the upper and on the lower membrane. The upper wave is slightly out of phase with the lower wave. The air flow passes through small cavities where the volume sometimes is bigger and sometimes smaller due to the difference in phase between the upper and the lower membrane. When the air passes different cavities it starts to pulsate. The pulsations are directly depending of the angular speed of the disc, this push-pull action creates a harmonic pulsation of energy..."*

[//jnaudin.free.fr](http://jnaudin.free.fr)



# SG203.5.15.3 Implosion for Levity (3) Dual Vortex Generator

Here are the explanations from J. L. Naudin's website:

*"The purpose of this generator is to generate a sufficient torsion effect in B-Field so as to create a bipolar magnetic vortex in the Ether medium (zero-point vacuum) itself. A vortex is an open system and it has self-sustained capabilities as long as a differential pressure exists between two layers. When the bipolar vortex is unbalanced it is also able to produce a thrust vs the vacuum medium due to the differential pressure induced. In the double vortex generator the rotational energy begins very strong in the center and the rotational speed increases dramatically while the radius of the vortex decreases. When the vacuum pressure is released at this point, the energy is free to explode radially. The energy released can be tapped by some output coils placed radially around the center."*

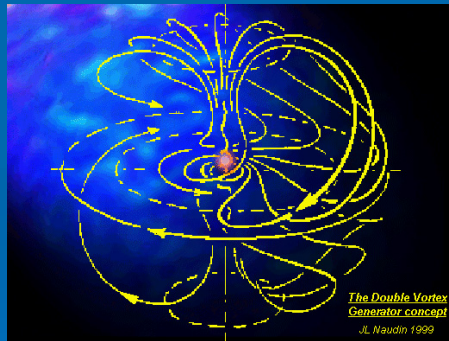

↑ Bipolar vortex concept



All images:  
[//jnaudin.free.fr](http://jnaudin.free.fr)

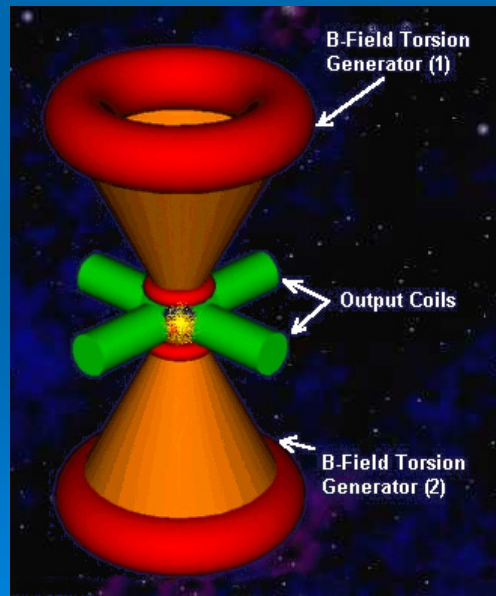

↑ The Dual Vortex Generator.  
J. L. Naudin

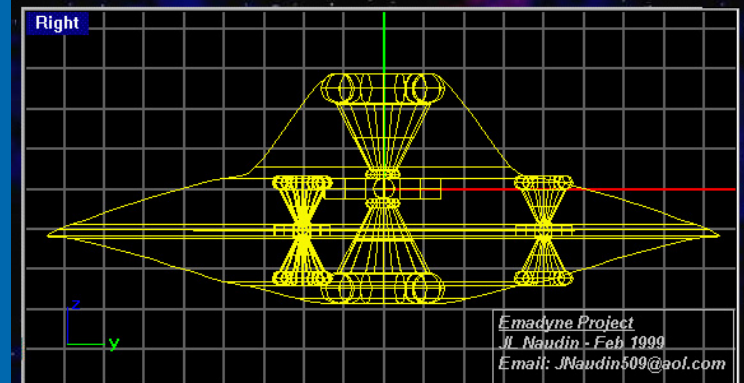
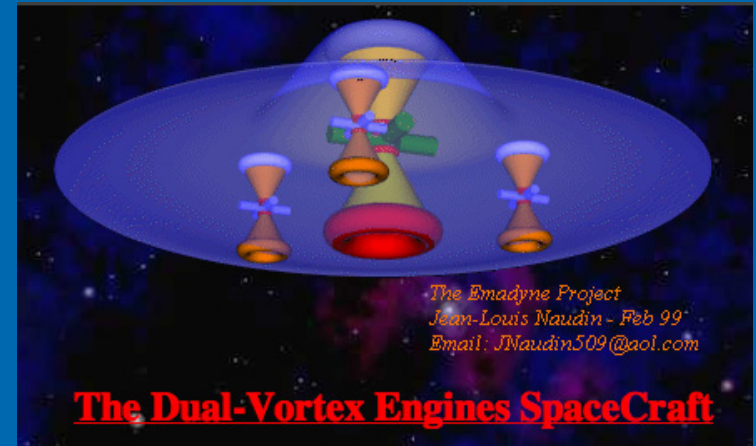



# SG203.5.16.1 Vortex Gallery (1) Vortices Above

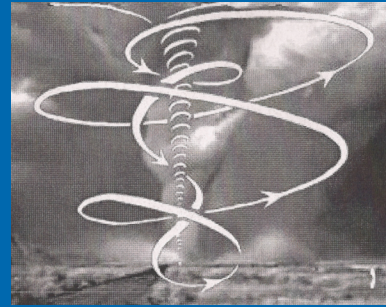

↑ Vortex model of tornadoe.



↑ Hurricane Katrina



← Hurricane. NASA.



↑ Multiple Tornadoes. [//hercules.gcsu.edu](http://hercules.gcsu.edu).



← Vortex train in clouds



## SG203.5.16.2 Vortex Gallery (2) Jupiter's Great Spot

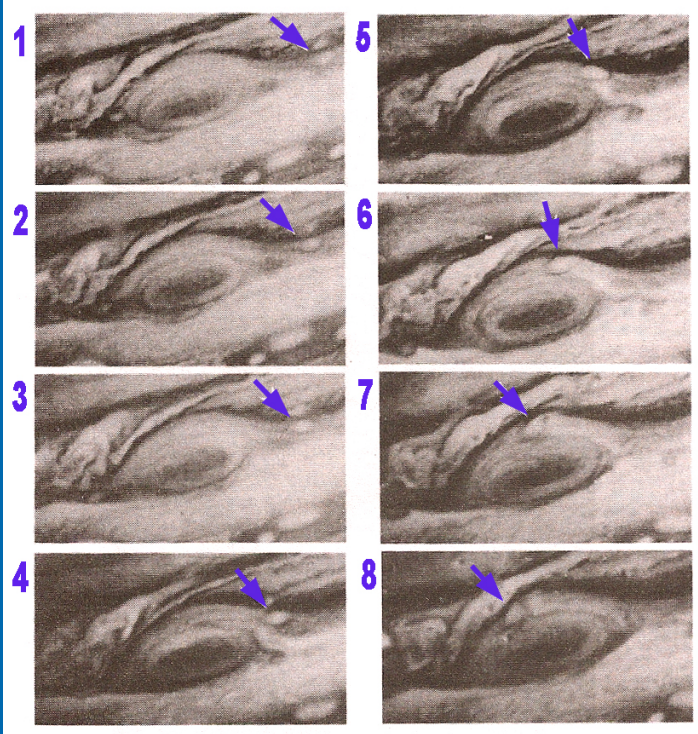

↑ In this NASA 1 to 8 sequence of images, taken over two weeks, a small vortex (blue arrow in image 1) is dragged into orbit around GRS and sucked in.

### GRS Temperature Gradient

Combining data from giant earth-based telescopes, astronomers have obtained thermal images of GRS with detail comparable to visible-light images from NASA's Hubble Space Telescope. The images show the most intense orange-red central part of the spot is about 3 to 4 Kelvin (5 to 7 degrees Fahrenheit) warmer than the environment around it. This temperature differential is enough to allow the storm circulation, usually counter-clockwise, to shift to a weak clockwise circulation in the very middle of the storm.

Note: V. Schauburger observed how small temperature changes would alter the qualities of naturally flowing water.

The atmosphere of Jupiter is the largest planetary atmosphere in the solar system. The Jovian atmosphere is home to turbulent phenomena, including hundreds of vortices. These oval structures are divided into:

- cyclones: rotating in the same direction as the planet i.e. counterclockwise in the Northern hemisphere and clockwise in the Southern.
- anti-cyclones: rotating in the reverse direction.

The two largest Jovian vortices are the Great Red Spot (GRS) and Oval BA or "Red Spot Junior". These two and most of the other large spots are anti-cyclonic.

Located in the Southern hemisphere, the GRS is the largest known vortex in the Solar System. It could engulf several Earths and has existed for at least 180 years and possibly as long as 345 years or more. GRS rotates counterclockwise, with a period of about six Earth days or 14 Jovian days. At the start of 2004, the Great Red Spot had approximately half the longitudinal extent it had a century ago, when it was 40,000 km in diameter. At the present rate of reduction it could potentially become circular by 2040 and/or Jupiter could lose its giant eye altogether. GRS also absorbs smaller vortices (see NASA sequence on left).

Oval BA, south of GRS, is a vortex that is 1/3rd the size of GRS and formed in 2000 from the merging of three white ovals. In 2006, Oval BA turned red as well.

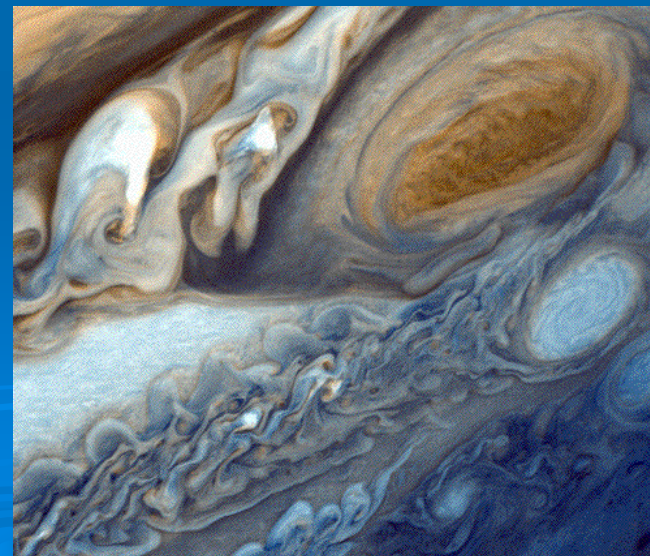

↑ GRS in relationship to Earth

← Great Red Spot in enhanced colors. (NASA, Voyager1).



## SG203.5.16.3 Vortex Gallery (3) Vortices Way Above

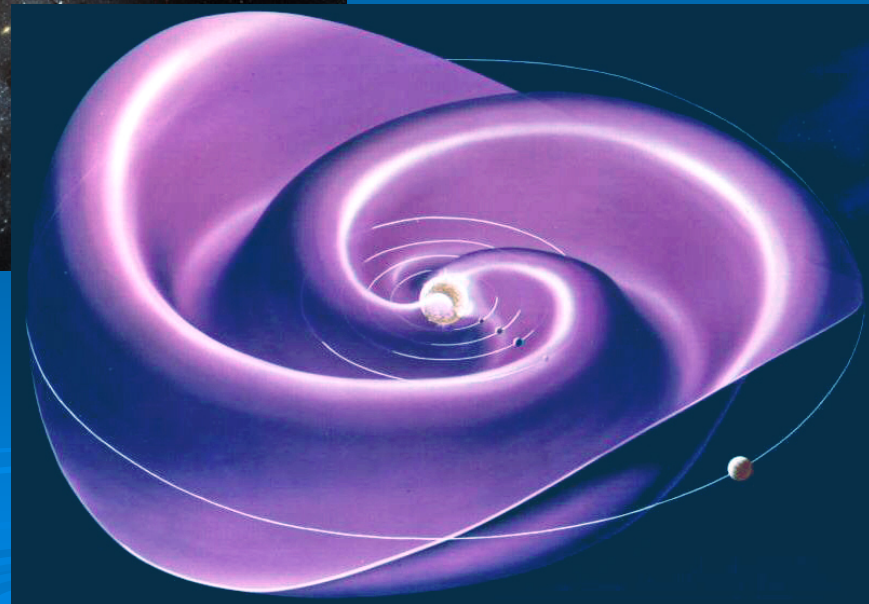

Sun's heliospheric currents →



# SG203.5.16.4 Vortex Gallery (4) Vortices Here



← Vortex wallpaper  
[www.torraspapel.fr](http://www.torraspapel.fr)



← Vortex Heart  
sculpture in a cup  
by [Robyn Gallagher](#)

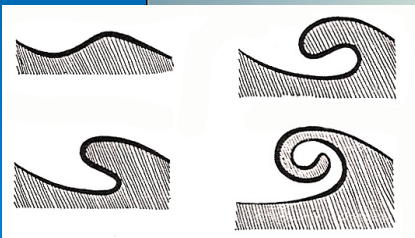
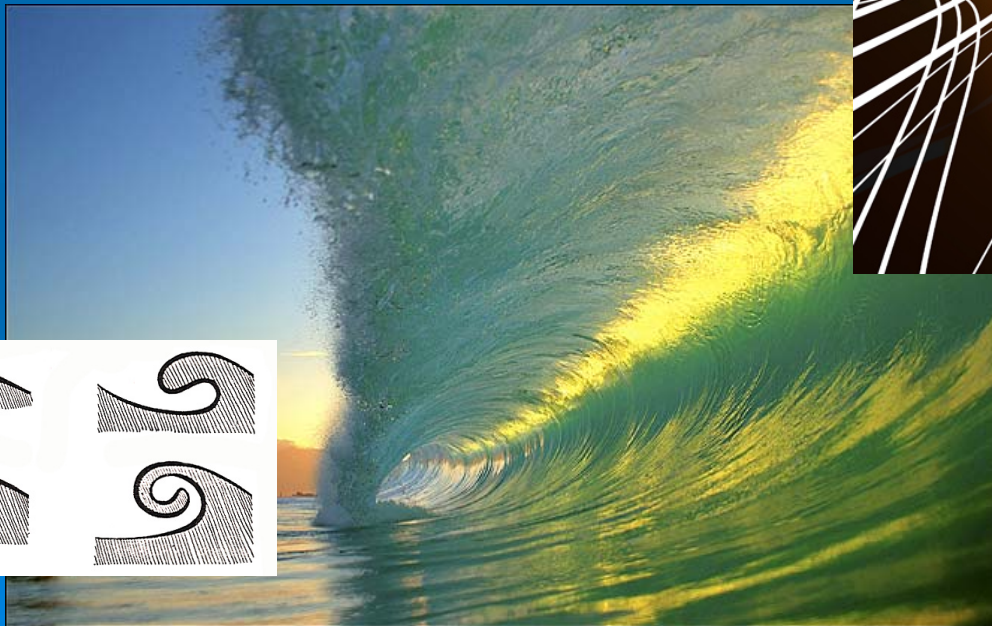
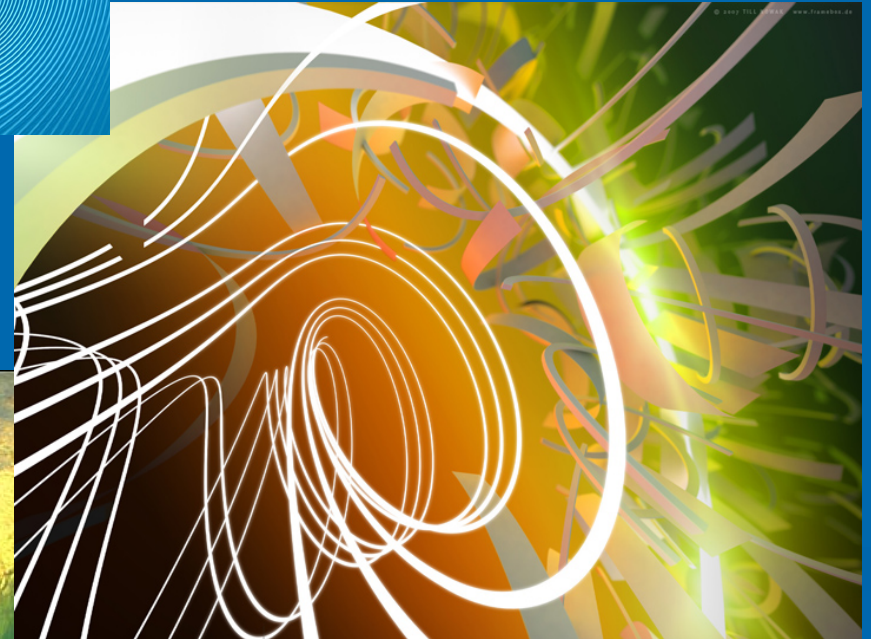

↑ Vortex wallpaper  
by Till Nowak. [www.framebox.de](http://www.framebox.de)

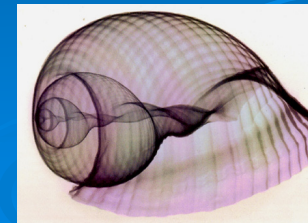

← X-ray of shell

↑ Unknown beautiful web image.



## SG203.5.16.5 Vortex Gallery (5) Vortices Way Below

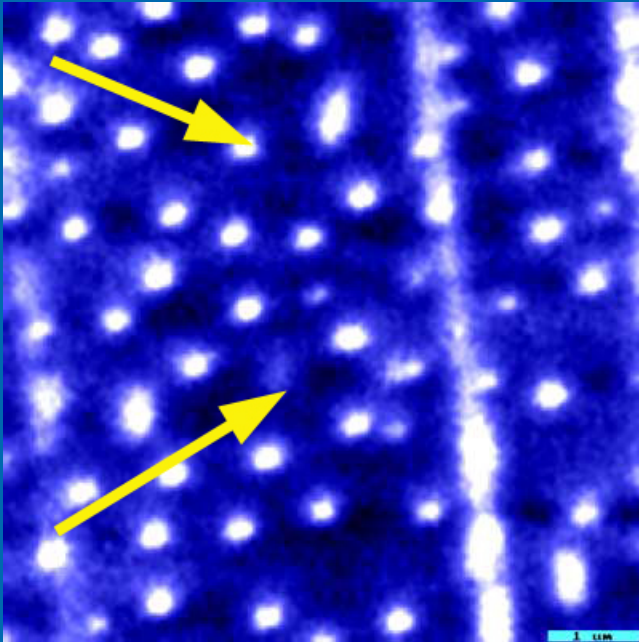

↑ Vortices in superconductors.

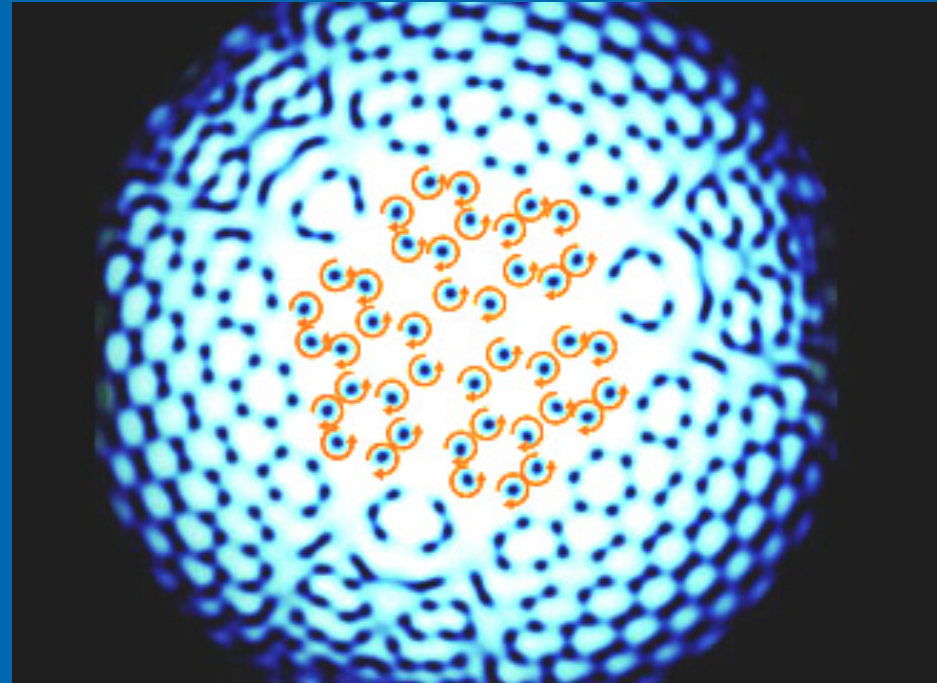

↑ In this simulation of a Bose-Einstein condensate, each vortex rotates in the opposite direction (shown by arrows) to its neighbors. (Gary Ruben, Monash University, Australia)



↑ Atomic vortices trails in cloud chamber

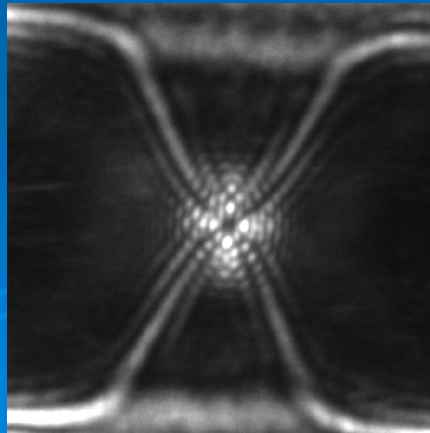

← A magnetic vortex found in an iron dot. Represented by means of Fresnel contrasts. Size: 200 nanometers. [//aurelien.masseboenf.free.fr](http://aurelien.masseboenf.free.fr)



# SG203.5.16.6 Vortex Gallery (6) The Human Vortex

In many wisdom and spiritual traditions, as well as reports of psychics, there is a reference to the energy field surrounding human beings and connecting them, through to the web of life, to the entire universe. This *auric field*, with its systems of mini-vortices called *energy centers* (or *chakras* = wheels in Sanskrit), is in itself a full, elaborate double vortex, from the magnetic field to subtle spirit layers. Below are some depictions of the human vortical energy field.

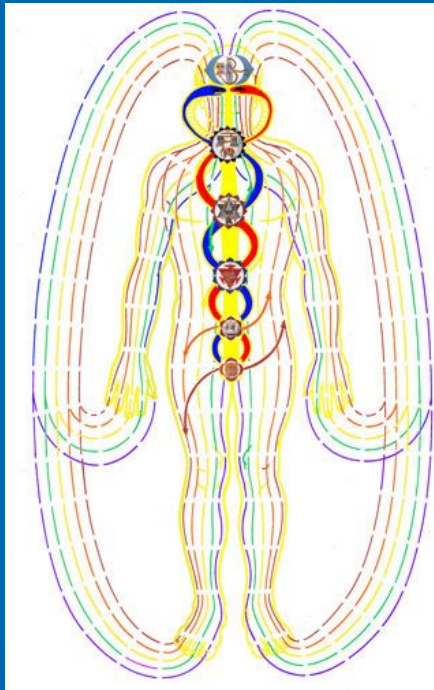

[www.lorinroche.com](http://www.lorinroche.com)

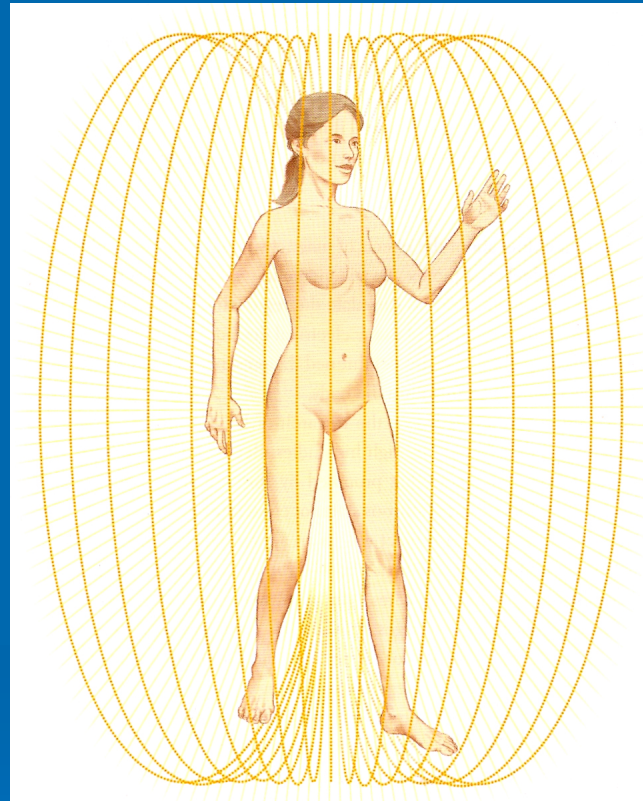

↑ The human magnetic field

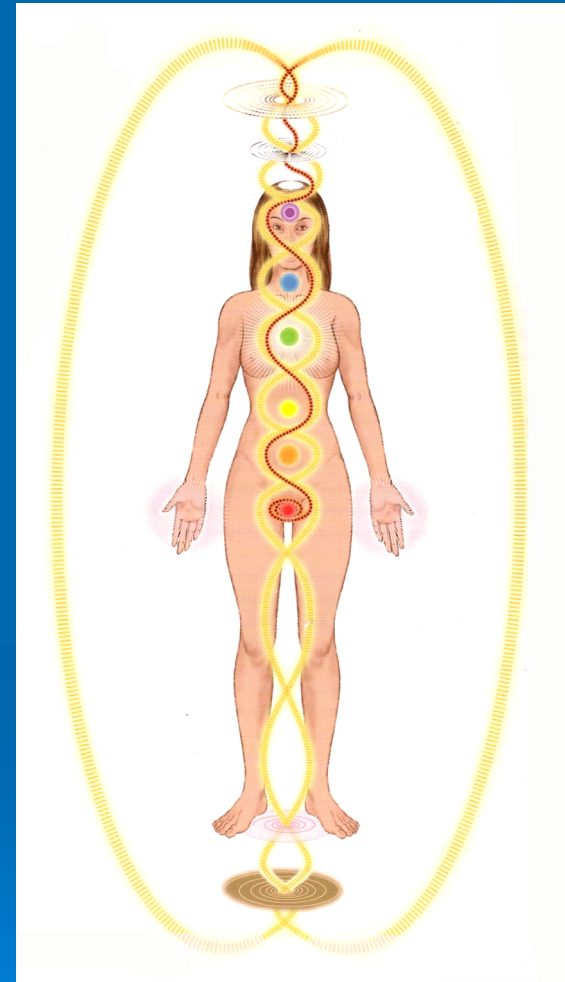

↑ A rendition of the double *Kundalini* flow through the *chakra* system.



[i3.ytimg.com](http://i3.ytimg.com)

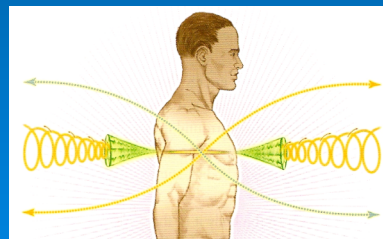

Heart Chakra as double vortex

↔ Images from Cyndi Dale. *The Subtle Body*. 2009.



# SG203.5.17.1 Vortex Art (1)

## Da Vinci

In his attempts to understand the patterns and forces at play in the element of water, Leonardo da Vinci produced sketches that were close to scientific diagrams. Da Vinci was literally fascinated by fluids, flows... and vortices. His uses of whirling, curving, waving, spiraling and meandering show how he was in tune with the rhythmic, we could even say 'fractal' and 'chaotic', live motion of water. His drawings of water are almost oriental, zen-style.

In the words of Philip Ball (*Flow* volume of *Nature's Patterns*, 2009):

*"(Leonardo) illustrates shock waves and ripples caused by constriction and widening of a channel, and his drawings of the flow past a cylindrical obstruction display the teardrop wake and the paired vortices that have been found in modern experiments. Fluid scientists today typically use techniques for revealing the flow-forms that Leonardo is said to have invented: fine particles that reflect light are suspended in the water or colored dyes are added to the flow: Leonardo was throwing saw dust into running streams..."*

Here are two quotes by Leonardo showing that he was an art-scientist of the vortex:

*"Observe the motion on the surface of the water which resembles that of hair... Thus the water forms eddying whirlpools, one point of which is due to the impetus of the original current and the other to the incidental motion and return flow."*

*"The whole mass of water, in its breadth, depth and height, is full of innumerable varieties of movements, as is shown on the surface of currents with a moderate degree of turbulence, in which one sees continually gurglings and eddies with various swirls..."*

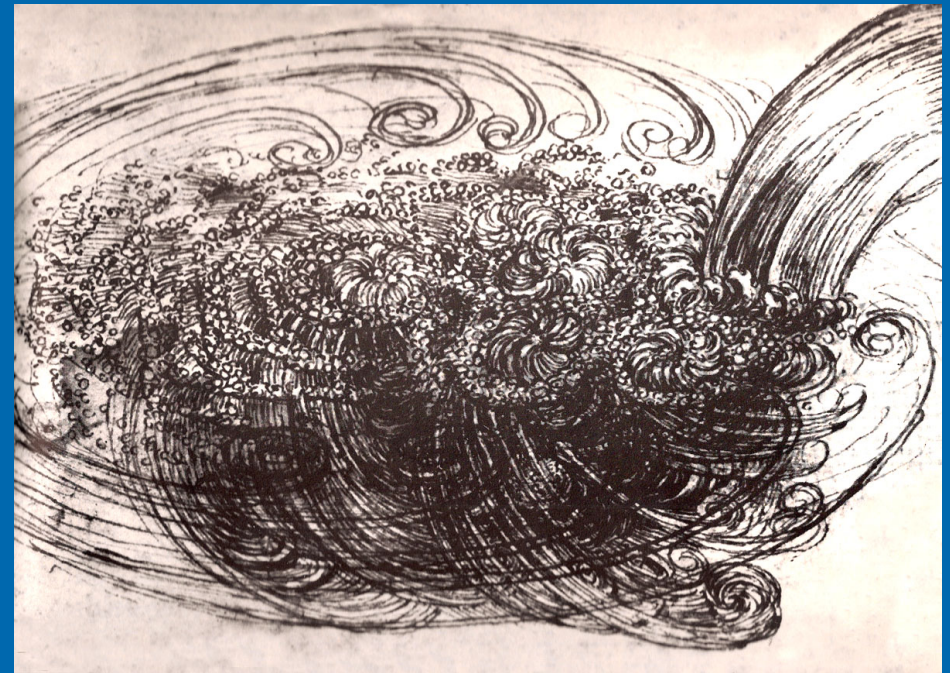

↑ Water pouring out of a square hole. This drawing was probably made in 1507 in connection with a hydraulic project. (Windsor, 12660v)



↑ Water vortices flowing around a flat plate. (Manuscript F)

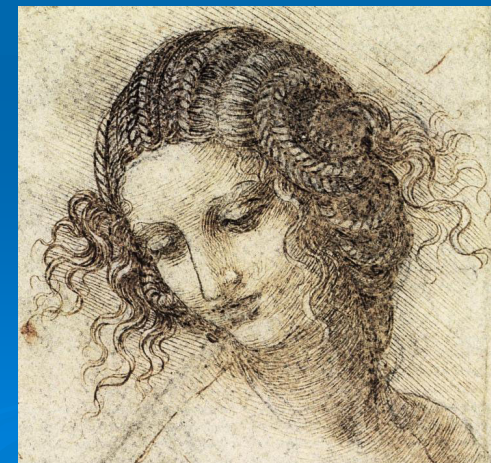

↑ Study of Leda. Note the vortex-like braids.



## SG203.5.17.2 Vortex Art (2) Van Gogh



"La Nuit Etoilée"  
(The Starry Night)  
— 1888



## SG203.5.17.3 Vortex Art (3) Water Sculptures

This remarkable water vortex educational sculpture was created by William Pye. He called it "Charybdis", after the Homeric legend. [www.williampye.com](http://www.williampye.com)



[Here is the story from the website:](#)

*"The sirens Charybdis and Scylla resided in the Sicilian Sea. Homer tells us that because Charybdis had stolen the oxen of Hercules, Zeus struck her with a thunderbolt and changed her into a whirlpool whose vortex swallowed up ships."*

*"In the water sculpture Charybdis, the circular movement of water inside a transparent acrylic cylinder forms an air-core vortex in the centre. Steps wrap around the cylinder and allow spectators to view the vortex from above."*

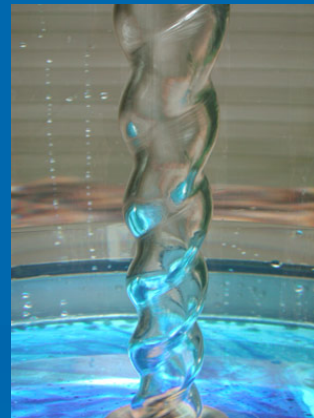

[See the "Vortex Fountain"  
video on youtube]





## SG203.6 Chapter 6. Golden Matrix Science



Whereas some substantial and already established discoveries, all pointing to a resurgence of Sacred Geometry knowledge, have been described in the preceding 5 chapters of SG203, this final chapter is more of an explorative nature, attempting to catch glimpses and a potential overview of this great leap forward that human consciousness - and therefore human science & technology -, is taking towards a greater expansion.

Here we are gathering the new clues we have as to a nascent scientific paradigm that can account for the many anomalies and puzzles popping up in the face of Newtonian and Einsteinian physics. In all fields of science, from genetics to cosmology, cutting-edge research is pointing to some larger, deeper, trans-disciplinary, multi-dimensional understanding of the dance of universal consciousness. An all-encompassing science-wisdom of the universe, from quantum to cosmos, is brewing to encompass nature, culture, life AND consciousness. Unification & Integration are "in the air"...

There is a nagging feeling among open-minded scientists that the science we know of now is but a restricted case of a much larger science. This larger science has to include consciousness and expose the obsolete lie that we are "observing nature" with "objectivity". We will describe some of the new discoveries and understandings that are the foundation of this evolutionary shift in science and awareness.

We will then focus on international research pointing to the ubiquitous and integrative role of the Golden Ratio as a universal constant which is structuring, on all scales, the most efficient, fractal transfer of energy/information. A "Theory of Special Fractality" might be underlying the Golden Cosmos.

**A reminder. We are all co-creating the next paradigm "equilibrium":  
it is in the making right now and will reflect the conscious input of all human players  
to converge to an optimal model of collective harmonic wisdom.**

## SG203.6.1.1 New Paradigm (1) End of Scientific Materialism

With the coming of the industrial age, human awareness has been progressively swept into a more & more materialistic view of life, the universe and consciousness. This still prevalent "model of reality" or "consensus of perception" is called *scientific materialism*: only that which can be measured and put into an equation is real, and this reality is only accessible to the rational mind. This materialistic paradigm took over the western countries in the last two centuries and has attempted to take over the entire world but the tide is changing and scientific materialism is now increasingly seen as an obsolete relic of the industrial age: the "old" paradigm.

**In a nutshell:** denying the existence of any reality other than the material reality IS an extremely *reductionist* approach to life, perception, knowledge and science itself: we could say that it is utterly un-scientific. There is growing realization that, for generations, we have been programmed to perceive a very *limited, impoverished layer of reality* based on the pre-eminence of the physical body, the logical mind and the supposed separation & competition between people and nations. We intuitively know that this is the root cause of the spiritual misery and social loneliness plaguing people in westernized countries: we have been forcibly divorced from the larger *web of life* and we suffer from existential or *bio-alienation*. And seeing the massive disappearance of bio-diversity coupled with the financial slavery of many, we also realize that we have been trained to blindly accept our exploitation and the destruction of our global resources for the exclusive, short-term benefit of the very few, backed by blind, greed-oriented corporations, explosion-based technologies & absurd military systems.

The old paradigm readily dismisses "meta-physical" realities, by definition deemed outside of the only reality there is: the physical realm. All the traditional, larger quests and questions of human life are regarded as unreal or, worse, the leftovers of primitive superstitions: the nature of being, the function of awareness & consciousness, the origin of the universe, life after death, the purpose of life, the power of unconditional love, healing & prayer, the visions of the great mystics and people endowed with psychic or shamanic abilities, ancient traditional wisdom, the nature of beauty and harmony, the hidden potential of human energy, the feelings of awe & sacredness... Current established science only feels secure and in control when focusing on small, fragmented, tangible aspects of the gigantic mystery that we can't even name and in which we have our being. Scientific materialism really was a dogma (*authoritative assertion of opinion*) presented as truth.

However, the wheel is turning and this old paradigm is rapidly shattering to pieces as new generations of humans, men, women and children, professional and non-professional, are coming into local & global responsibility, ready to enact a clearer vision of the life we want. The growing discrepancy between the old paradigm of separation & selfishness and the excitement of glimpsing everywhere new solutions, new technologies, new strands of inter-connectivity IS the human factor driving all the current changes. Humanity, as integral part of the cosmos, has been moving through various historical cycles or phases of consciousness evolution and is now learning to put together the many lessons offered by the past, expanding from local to global concerns, questioning dogmas & mindsets... Eventually we are facing the challenge and gift of these very times of NOW: coming to an increasingly larger view of reality that can synthesize the conflicting positions of the past and bridge over to an unifying knowledge, science, technology and way of managing the common resources for the benefit of all people and the respect of all nature.

There seems to be an evolutionary human urge to progressively expand the scope of human consciousness and eventually match the potential power of cosmic co-creation that is seemingly built into the human experience. Moreover, this evolutionary way to cosmic godhood appears like an apprenticeship that is carefully orchestrated by larger aspects of the universal consciousness. The collective feeling is now swinging from fear, ignorance, submission and anger to a rising awareness of potential freedom: the personal & collective changes have a benevolent purpose, we can participate in many creative ways and we are moving into a place of exciting, global re-invention of what we want this human experience to be, for ourselves and our children's children.

*"The materialists have decided that metaphysics is irrelevant to the pursuit of scientific fact.  
Yet the decision to ignore metaphysics is not based on any fact, and is itself a negative metaphysics."*

Herbert Bangs. *The Return of Sacred Architecture*. 2007.



## SG203.6.1.2 New Paradigm (2) Dirac's Harmonic Insights

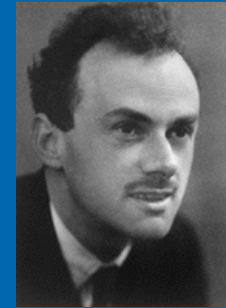

← Paul Dirac

Dirac is a typical example of a scientist on the cusp of two paradigms.

Paul Adrian Maurice Dirac (1902-1982) was one of the most brilliant and influential physicists of the 20th century. He made fundamental contributions to quantum physics and, in 1928, he combined relativity and quantum mechanics in the *Dirac Equation*, which provides a natural description for the spin of the electron and which led to the prediction, by Dirac himself, of the existence of anti-matter. In 1933, Dirac shared the Nobel Prize in physics with Erwin Schrödinger.

Besides being a physics luminary and being socially shy (the "*Dirac unit of speaking*" was jokingly measured as "one word per hour"), Paul Dirac left us two insights on the nature of cosmic harmony: his Principle of Beauty and his Large Numbers Hypothesis.

### Dirac's Principle of Beauty

As explained by Alexey Stakhov, at Moscow University, there is a tradition that a distinguished visiting scientist is requested to write on a blackboard a self-chosen quotation. When Dirac visited Moscow in 1956, he wrote: "*A physical law must possess mathematical beauty.*" This inscription is the famous *Principle of Mathematical Beauty* that Dirac progressively developed during his scientific life.

Dirac believed that nature was constructed in accordance with the principle of mathematical beauty. Continuing the historical lineage of great thinkers (Plato, Galilei, Kepler, Leibniz, Einstein, Minkowski...) who stated that God/Nature was a master mathematician, Dirac wrote in 1969: "*One could perhaps describe the situation by saying that God is a mathematician of a very high order, and he used very advanced mathematics in constructing the universe.*"

When one thinks of it, Dirac's Principle of Beauty is actually shifting back the whole of science to a philosophical/aesthetic basis. In her book *Dirac: A Scientific Biography* (1990), Helge Kragh quotes Dirac going as far as stating: "*A theory with mathematical beauty is more likely to be correct than an ugly one that fits some experimental data.*" In Dirac's view, lack of beauty points to imperfections in the equations and a need for their improvement.

Minkowski's most famous disciple, Einstein, was an important inspiration for Dirac who saw in the Theory of Relativity a prime example of a mathematical/aesthetic approach to science. We certainly are reminded here of Plato pointing to *noumenal archetypes* (such as Beauty and Geometry) behind the phenomenal world.

However, as pointed out by Helge Kragh, Dirac's attitude was quite ambiguous and conflictive when confronted with real cases of physics. Dirac belonged to a period of transition between paradigms and yet was clearly longing for the beautiful, simple, "obvious", unified knowledge that may soon be emerging as the human species keeps moving into the omni-connectedness of expanded consciousness.

### Dirac's Large Number Hypothesis

Another of Dirac's "harmonic" insights is the so-called *Dirac Large Numbers Hypothesis* (or LNH) which refers to an observation he made in 1937 relating ratios of size scales in the Universe to that of force scales.

The ratios constitute very large, dimensionless numbers: some 40 orders of magnitude in the present cosmological epoch. According to Dirac's hypothesis, the apparent equivalence of these ratios might not be a mere coincidence but instead could imply a cosmology with these features:

- The strength of gravity, as represented by the gravitational constant, is inversely proportional to the age of the universe.
- The mass of the universe is proportional to the square of the universe's age.

LNH was Dirac's personal response to a set of large number 'coincidences' that had intrigued other theorists at about the same time: Hermann Weyl speculated about the relationship between the radius of the universe and the radius of the classical electron, Arthur Eddington related the previous ratios to the estimated number of charged particles in the universe etc... The ratios involved were of the order of  $10^{40}$  (Dirac) and  $10^{80}$  (Eddington).

Wikipedia notes: "*Dirac's theory has inspired and continues to inspire a significant body of scientific literature in many disciplines.*" Various scientists have introduced new sets of ratios such as  $10^{60}$  when measuring cosmological elements in Planck units. Another ratio (120 orders of magnitude or  $10^{120}$ ) has emerged lately, reflecting the expansion of the scientific understanding of the universe:  $10^{120}$  has been associated with ratio of the theoretical and observational estimates of the energy density of the vacuum, as well as the sum of elementary events or bits of information in the universe...

Dirac's and others' *Large Numbers* are showing the re-emergence of the sense of a pre-established harmony and proportional construct in the universe, as described by ancient wisdom. LNH and such were preliminary glimpses into what is now called *Global Fractal Scaling* (see further).

## SG203.6.1.3 New Paradigm (3) Call for Grand Unification

The call for Grand Unification is resounding within the human consciousness. Beyond the GUTs (Grand Unified Theories) and the TOEs (Theories of Everything), that scientists are grappling with, we may soon have a whole new body of expanded knowledge.

A Theory of Everything could, theoretically, be the result of some very simple set of conditions that could generate everything in the entire universe, a sort of elegant Song that would contain within it a simple instruction set that could create the entire universe.

The Hindu traditional wisdom presents this very idea: it is called the OM. The OM is said to be the fundamental universal vibration that contains all harmonics and sub-harmonics, and that which everything in existence resonates to.

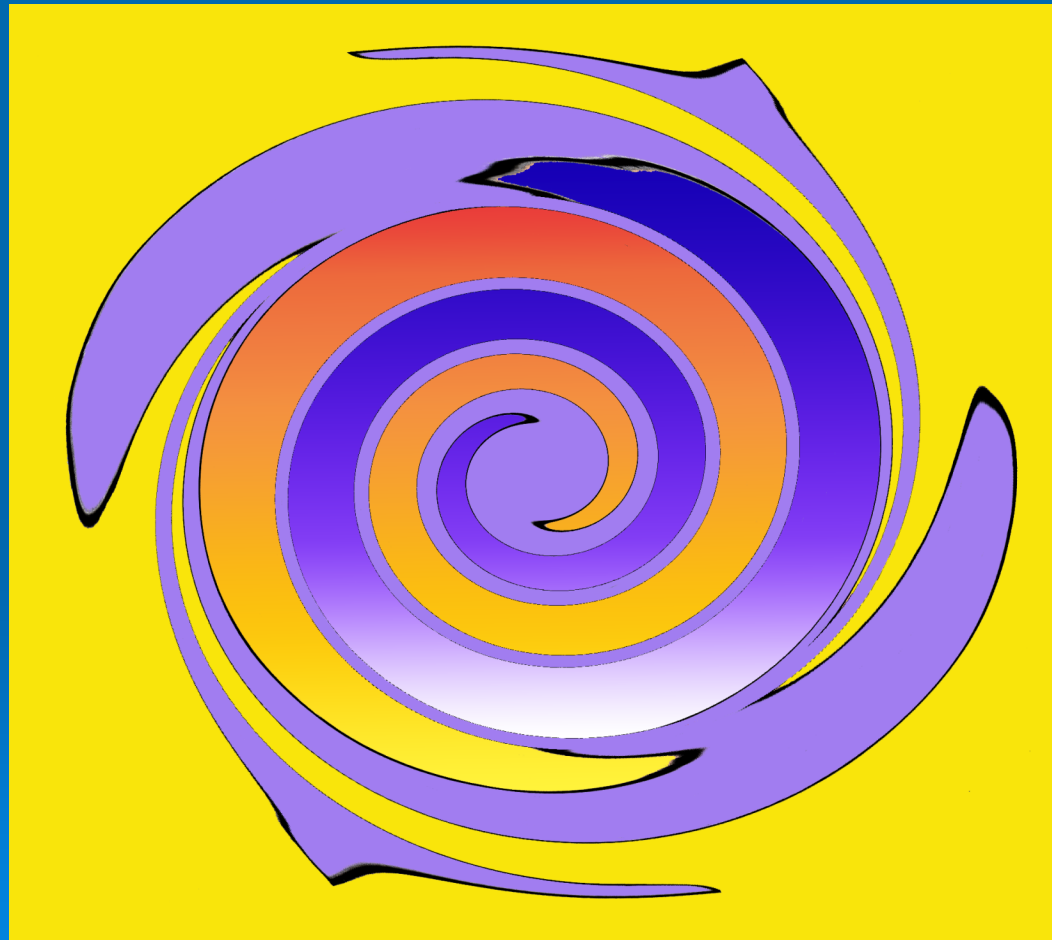



## SG203.6.1.4 New Paradigm (4) The New Faces of the Cosmos

The paradigm shift occurring now in science is due to a number of experimental findings that do not fit into the established theories and point to the hitherto unsuspected quality of COHERENT INTER-CONNECTEDNESS in the universe. It is a type of coherence that means non-local (instantaneous) communication between parts and whole systems, using connections that are beyond the conventional space/time parameters. It appears that the cosmos is made up of a "*nested hierarchy of non-locally connected coherent systems*" (Ervin Laszlo. *The Connectivity Hypothesis*. 2003.)

Here are some brief descriptions of the new 'faces' of the cosmos, as uncovered by new paradigm scientists. Note how, under their new scientific-sounding names, they are strangely familiar and how they are all facets of a same larger, universal super-mandala of "Harmonic Oneness".

- **INTER-CONNECTIVITY.** All parts of a system interact with each other in dynamic equilibrium. A system can't be understood through its parts alone. Expanded to the entire universe: "*All things that exist are and remain, intrinsically and intimately, connected*" (Laszlo).
- **COHERENCE.** Two waves are coherent if they have a constant difference in phase i.e. if their phases conjugate to form positive interference. Coherence, self-coherence and supra-coherence have been found in cosmology, quantum physics, biophysics, biology and consciousness research.
- **NON-LOCALITY.** Direct influence of one object on another distant object, in violation of the principle of locality (which says: objects are only influenced by their environments). It is a form of action at a distance.
- **SCALE-INVARIANCE.** Scale invariance is a feature of objects or laws that do not change if length scales (or energy scales) are multiplied by a common factor. The Golden Ratio is scale-invariant: it applies regardless of the scale. The universe is now found to exhibit Global Scaling.
- **SELF-SIMILARITY.** A self-similar object is exactly or approximately similar to a part of itself (i.e. the whole has the same shape as one or more of the parts). Self-similarity is a typical property of fractals. Recursiveness (or nestedness) describes a process of repeating objects in a self-similar way.
- **GOLDEN FRACTALITY.** Fractal self-similarity perfected by the Golden ratio. With the reduction factor of  $1/\Phi$  (.618), fractal branches touch but do not overlap. The universe might well be a fine-tuned Golden Fractal Cosmos.
- **QUANTUM PLENUM MATRIX.** It has been recognized that the "Zero Point" vacuum, far from being "empty", was thriving with "fluctuations" and tremendous energies. In fact, the Zero-Point Field (ZPF) is now called a "plenum" as it seems to carry all the universal forces of nature.
- **VORTEX DYNAMICS.** The primary dynamic motion of all energy, on all scales.
- **IN-FORMATION.** Information is discovered as being an inherent aspect of nature, on a par with energy. An "informed universe" is "meaningful".
- **SELF-ORGANIZATION.** Process whereby a structure appears in a system without an external authority. Observed in physics of non-equilibrium systems and mathematics of cellular automata, self-organization also shows up in natural and social systems.

*We have already addressed the concept of scale-invariance in dimensionless quantities (Golden ratio) and self-similarity (nestedness) in fractals, we have touched upon vortex science and its new technological possibilities. We are going next to briefly discuss the new findings about coherence, inter-connectedness and non-locality, global scaling as well as the concepts of a quantum vacuum/plenum and a cosmos of in-formation able to self-organize. We will then be ready to review the emergence of the Golden ratio as a candidate universal constant in a super-coherent, Golden cosmos.*

# SG203.6.2 A Coherent Cosmos

It has been said that science is currently in a state of "creative chaos", brewing a whole new understanding of the universe. At the core of this new scientific paradigm is the growing recognition of hitherto unrecognized levels & depths of COHERENCE. The very word "coherence" points to integration, unification, harmonization and sustained balance. It is a powerful concept helping us to heal from recent extremes of fragmented scientific perception and to uncover with new wonder previously unsuspected degrees of unity in nature, life, culture and consciousness. We are on the return journey to the long lost "Harmonic Oneness". As we recover our inner spirit coherence, we see it reflected back at us from outside.

Below, we are pointing to the current rediscovery of coherence at various scales and in various domains of observation & experimentation. This deeper coherence displays a quasi-instant correlation of the constituents of a system that seems to be time- and space-invariant. This can only be explained by a larger paradigm involving a meta-field of universal self-organization.

• **Coherence in Cosmology.** As astronomical probes reach wider and deeper, there is growing evidence that non-classical coherence occurs on cosmological scales. A large amount of mass & energy is unaccounted for: this is the "missing mass" puzzle pointing to an underlying coherent substratum. The "horizon problem" is the observation of the large-scale uniformity of the cosmos at all points of the horizon as seen from earth: this contradicts the "Big Bang" theory as, even at distances not connected by light, the universe evolves as a coherent whole. Moreover, the "fine-tuning" of the cosmological constants, involving upwards of 30 factors, is astonishingly precise. As pointed out by Ervin Laszlo: "*The universe is far more complex and coherent than anyone other than poets & mystics have dared to imagine*". The new glimpses of cosmological coherence points to the possibility of a *Metaverse*, or precursor mother-universe providing a super-coherence to our daughter universe.

• **Coherence in Quantum Physics.** The quanta of light & energy emerging from sophisticated experiments are no longer "billiard balls": they exhibit levels of wave function coherence with time/space transcending properties. Wave state superposition, behaviors of non-locality & inter-connectedness (see next page), wave function collapse through observation, primordial entanglement and high sociability... In the latest theoretical developments, the quantum world seems to interact with the deeper dimension of a multi-dimensional cosmic field. The quantum "weirdness" is now related to a larger, coherent context, an "implicate order" (Bohm).

• **Coherence in Biology.** Instant, multi-dimensional correlations are coming to light between the parts of a living organism and between organisms and their biospheres, near and far. "*Cutting-edge research in quantum biology finds that atoms & molecules in the organism, and even entire organisms and their environments, are nearly as 'entangled' as micro-particles that originate in the same quantum state.*" (Laszlo). This goes beyond a strict biochemical signaling and suggest that, at the macro-scale level of life, a quantum-type coherence is directly involved. The dynamic equilibrium of living systems calls for a high degree of coherence involving quasi-instant long-range correlations, such as the highly "adaptive" response of the genomic mutations, found to even interact with conscious intentions. Again we have here hints of a background field (bio-field) of information coordinating the coherence of living systems.

• **Coherence in Consciousness.** The connective "communion" that binds an individual consciousness to other people's consciousness and to the whole universe has been the basis of traditional wisdom, the world over. This is being rediscovered as *trans-personal connectedness* and *spontaneous transference* (the traditional psychic abilities of telepathy, empathy, clairvoyance...). The ability of a person to act on the mind or body of another by healing or prayer is a new branch of medicine called *telesomatic* or *non-local medicine*. The time-space invariant occurrence of universal symbols, archetypes or ideas and the science of "sync" (synchronistic coherent behavior of systems like fire-fly or human populations) point to a whole system type of event orchestration. Consciousness itself seems to be a highly coherent and super self-organized system with multi levels of reality access.

*The new "coherence" findings could be explained by a fundamental information field at a primordial level of the universe, a "Source Love-Field".*

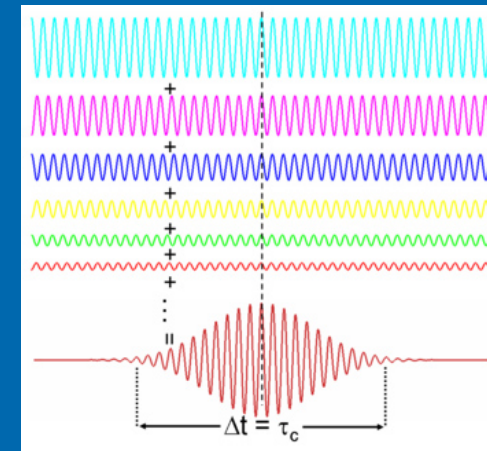

← When in phase conjugation, waves of different frequencies form a coherent pulse.

(Wikipedia).



# SG203.6.3.1 A Non-Local & Inter-connected Cosmos

Chaos Theory can be defined as the study of forever-changing complex systems. Discovered by a meteorologist in 1960, chaos theory contends that complex and unpredictable results will occur in systems that are *sensitive to small changes* in their initial conditions. The most common example of this, known as the "*Butterfly Effect*", states that the flapping of a butterfly's wings in China could cause tiny atmospheric changes which over a period of time could effect weather patterns in United States.

This kind of inter-connectivity eventually leads to non-classical correlations between observable physical properties of remote systems, often referred to as non-local correlations or *non-locality*. The property of *quantum non-local connection* or *entanglement* was recognized as a consequence of quantum theory and is at the heart of the *EPR paradox* (1935) and was experimentally verified for the first time in 1982 by physicist Alain Aspect.

*Entanglement* is one of the properties of quantum mechanics that caused many physicists, including Albert Einstein, to dislike this formulation of quantum mechanical theory. In 1935, responding to Niels Bohr's advocacy that quantum mechanics as a theory was complete, Einstein, Podolsky, and Rosen formulated the EPR paradox. The quantum mechanical thought experiment concluded that either non-local interaction exists or quantum mechanics is incomplete as a theory. Einstein famously derided entanglement as "*spooky action at a distance*". It was his belief that future mathematicians would discover that quantum entanglement entailed nothing more or less than an error in their calculations. As he once wrote: "*I find the idea quite intolerable that an electron exposed to radiation should choose of its own free will, not only its moment to jump off, but also its direction. In that case, I would rather be a cobbler, or even an employee in a gaming house, than a physicist*".

In 1964, John Stewart Bell derived an upper limit, known as *Bell's inequality*, on the strength of correlations for any theory obeying "local realism". Accordingly, quantum predictions can lead to correlations stronger than this limit, showing results that are experimentally distinguishable from the results of local hidden-variable theories. In 1982, Alain Aspect's and subsequent experiments have proven that non-local interactions do occur.

Normally under the *Copenhagen interpretation*, the state a particle occupies is determined the moment the state is measured. However, in an entangled pair when the first particle is measured, the state of the other is known at the same time without measurement, regardless of the separation of the two particles. This knowledge of the second particle's state is at the heart of the debate. If the distance between particles is large enough, information or influence might be traveling faster than the speed of light which violates the principle of special relativity. One experiment that is in agreement with the effect of entanglement "traveling faster than light" was performed in 2008 and found the "speed" of quantum entanglement has a minimum lower bound of 10,000 times the speed of light. The experiments show that the connection between the particles is not transmitted through the measuring apparatus but is **INTRINSIC** to the particles themselves: there is an **INNER**, holographic, multi-dimensional coding in all aspects of the universe.

As a temporary conclusion, we can say that the old paradigm universe,  
appearing to be made of separate entities only subjected to local direct influence,  
is now increasingly understood as cosmically entangled in ways we are barely beginning to uncover,  
such a quantum atomic teleportation (see next page).

Eventually, non-locality may prove to be the universal rule  
and space-time dependent locality the exception.

## SG203.6.3.2 Quantum Atomic Teleportation

A decade ago, the idea of teleportation was mere science fiction. But following the pioneering proposal of Bennett *et al.*, quantum teleportation has emerged as an important tool in quantum-information science. Recent experiments show that a form of non-local connectivity or "teleportation" shows up not only between individual quanta, but also between entire atoms.

"Quantum teleportation" or *entanglement-assisted teleportation* is quite different from the teleportation we know from science fiction. It is a technique used to transfer quantum information from one quantum system to another. Rather than picking one object up and "beaming" it somewhere else where a perfect replica is made, quantum teleportation involves *entangling* two things, like photons or ions, so their states are dependent on one another and each can be affected by the measurement of the other's state. When one of the items is sent a distance away, entanglement ensures that changing the state of one causes the other to change as well, allowing the teleportation of quantum information, if not matter.

Quantum teleportation in itself is intriguing but beaming *qubits* not just from one atom to another but among a large number of particles simultaneously would be the basis for an entirely new family of quantum super-luminal computers. A distinguishing feature of quantum teleportation is that it can transmit the information present in a quantum *superposition* (the quality of being in multiple states at the same time, before the *collapse* or *decoherence* into certain properties by measurement).

Ervin Laszlo comments: "*Non-local interaction is instant 'in-formational' interaction and it is best viewed as the function of a physically real information-field.*"

### A Brief History of Quantum Teleportation

- 1993. Charles Bennett and colleagues described a remarkable protocol for transporting a quantum state from one location to another, a protocol that succeeds even when the quantum state is completely unknown at the respective sites. Such quantum teleportation makes use of an extraordinary quantum resource, namely *entanglement* between two systems.
- 1997. Teleportation experimentally proven in regard to the quantum state of photons in light beams and the state of magnetic fields produced by clouds of atoms.
- 2004. Colorado experiments led by M. D. Barrett showed that the quantum state of entire atoms can be teleported by transporting the *quantum bits* ("qubits") that define the atoms. The ground state of beryllium atoms was successfully teleported.
- 2004-2008. In Innsbruck, Austria, experiments headed by M. Riebe successfully teleported the ground and metastable states of magnetically trapped calcium ions.
- 2010. In China, scientists have succeeded in teleporting information between photons further than ever before. They transported quantum information over a free space distance of 16 km (10 miles), much further than the few hundred meters previously achieved, which brings us closer to transmitting information over long distances without the need for a traditional signal. In this particular experiment, researchers maximally entangled two photons using both spatial and polarization modes and sent the one with higher energy through a ten-mile-long free space channel. They found that the distant photon was still able to respond to changes in state of the photon they held onto even at this unprecedented distance.  
The distance of 16 km is greater than the effective aerosphere thickness of 5-10 km, so the group's success could pave the way for experiments between a ground station and a satellite, or two ground stations with a satellite acting as a relay. This means quantum communication applications could be possible on a global scale in the near future.

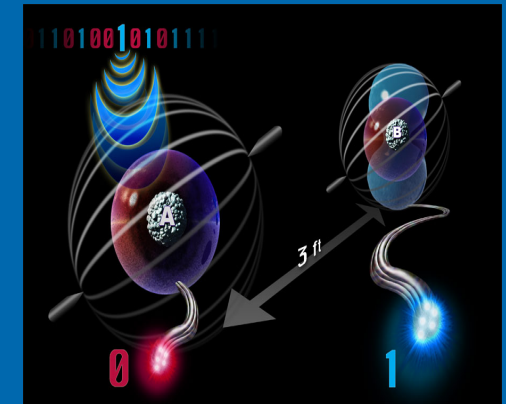

↑ Atoms on a quantum state of entanglement.  
Credit: N. R. Fuller, NSF.



## SG203.6.4.1 A Scale-Invariant Cosmos (1) Log Scaling

Over decades of scientific research, a colossal data base has been accumulated. It contains the spectral lines of atoms and molecules, the masses of the elementary particles and atomic nuclei, atomic radii, dimensions, distances, masses and periods of revolution of the planets, moons and asteroids, the physical characteristics of stars and galaxies, and much more. Ranging from elementary particles to galactic clusters this scientific data base extends over at least 55 orders of magnitude. Yet, despite its tremendous cosmological significance this data base has not been the object of an integrated investigation until recently.

Decades ago already, biologists had discovered that organisms whose body sizes proved to be within certain ranges of measurement seemed to have much better chances of survival and reproduction. In 1980, Ukrainian biologist Cisenko published his work "*Structure of Fauna And Flora With Regard to Body Size of Organisms*" proving that segments of increased species representation were repeated on the logarithmic scale of body sizes in equal intervals (approx. 0.5 units). This was documented on thousands of species of mammals, reptiles, birds, fish, amphibia, insects as well as numerous plants, fungi and bacteria. The phenomenon is not explicable from a biological point of view. Nowadays, this phenomenon is recognized as *logarithmic scaling* in the frequency distribution of biological species with reference to the body size and body mass of organisms.

At about the same time, physicists discovered a similar phenomenon of scaling (logarithmic scale invariance) in the frequency distribution of elementary particles based on the particles rest mass. In 1982, Hartmut Müller was able to show this for all known particles, nuclei and atoms, and also for asteroids, moons, planets and stars.

Scaling is a global phenomenon, in fact, it may be the very blueprint of the universe itself. We like to think in linear scales and are used to measure in nice and regular intervals. Other scales are unfamiliar to us. Natural science sciences use linear measures in the mathematical descriptions of many of their models. With the advent of fractal mathematics, linear scales are now replaced by fractal, hyperbolic, golden-ratio scales featuring a basic scale-invariance. In physics and mathematics, scale invariance is a feature of objects or laws that do not change if length scales (or energy scales) are multiplied by a common factor. This is also called *dilatation* which is part of a larger *conformal symmetry*. Conformal geometry is the study of the set of angle-preserving (conformal) transformations in a given space.

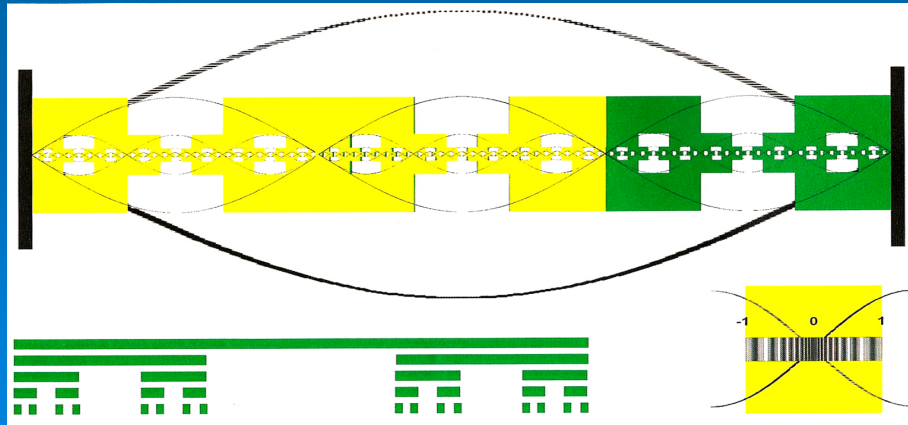

← The distribution of matter in the logarithmic space of scales/measures (top) has at first approximation the fractal dimension of "Cantor dust" (down left) but is transformed hyperbolically in the vicinity of a node point (down right).



↑ The fractal Koch curve.

## SG203.6.4.2 Scale-Invariance (2) Global Scaling

In a series of articles (1982-1989 - Russia), Müller first published the fundamentals of a theory of Global Scaling. The main articles have been published by *Raum & Zeit* (Special 1 Global Scaling) as Müller relocated to Germany in 1991. Dr. Müller is heading the [Institute of Space-Energy-Research](#) in Wolfratshausen, Germany.

Müller's theory is based on the statistical analysis of huge amounts of data and is being successfully applied in science and technology today. Global Scaling Theory is the first of its kind to mathematically describe the distribution of preferred parameter values in nature and also to explain the cause for this distribution. In depth mathematical investigation of the phenomenon has shown that the most appropriate model is the concept of standing wave processes on the logarithmic (and not on the linear scale). The observed dimensions of all objects in the universe, from atoms to galaxies, is determined by interaction with standing wave processes known as *density-pressure waves* propagating in the vacuum. Pressure waves are to be clearly differentiated from electromagnetic or gravitational waves: they propagate through the super-dense cosmic medium (Universal Field) and exist in macroscopic analogy to the phenomenon of non-locality in quantum physics, everywhere simultaneously.

The sum of probabilities that makes a certain physical value appear at a certain position along the logarithmic scale can be graphically represented by means of the Müller fractal. Knowledge of just this fractal set combined with additional understanding as to how the fractal is used in a specific application allows the Global Scaling engineer to quickly and efficiently prognosticate values and parameters that otherwise would have been found only through a tedious process of trial and error. Thus it is not surprising that applications that have worked in a stable way for several decades will show measures completely compatible with Global Scaling.

According to Ervin Laszlo, *"because the universe is finite, at the critical dimension points, the pressure waves superpose and create enduring standing waves. These waves determine physical interactions by setting the value of the various physical forces. By means of resonance, they amplify some vibrations and repress others; they are thus responsible for the distribution of matter throughout the cosmos. All processes have an inner rhythm according to their resonance with the vacuum's standing waves. Müller concludes that the vacuum is an ultra-weak background that acts as a morphogenetic field."*

**Recent findings confirm the presence  
of pressure waves in the vacuum.**

**A wave generated by a massive black hole in the Perseus cluster  
was found to have a frequency of 57 octaves below middle C.**

Dr. Hartmut  
Müller →



### Global Scaling

At Last!  
A New Physics  
and Holistic Science

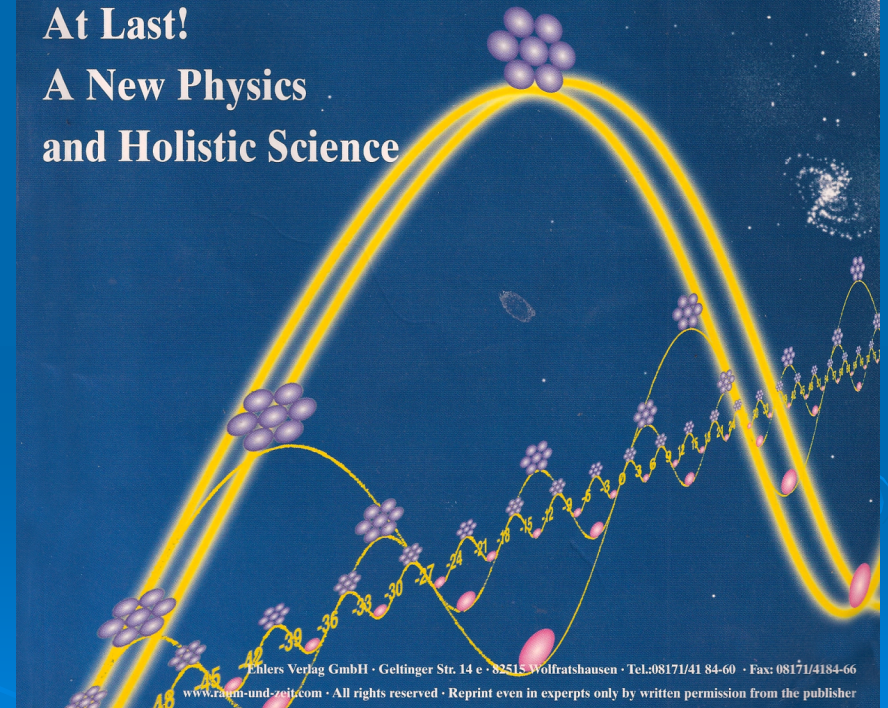



## SG203.6.4.3 Scale-Invariance (3) G-Com Tech

On October 27th, 2001, a historic scientific experiment was carried out between Bad Tölz, Germany and St Petersburg, Russia: the first language transmission by means of standing gravitational waves. These waves, described by the Global Scaling Theory, are naturally existing cosmic pressure waves that permeate the whole universe setting it into synchronous vibrations on all levels of scale. [For more on the Cosmic Field, see further].

The development of a *gravity-electric energy converter* in 1998 allowed the breakthrough and the subsequent public demonstration and release of the basic technology by Hartmut Müller and his Institute for Space-Energy-Research (IREF). The transmission was achieved without the need for a transmitter and without the generation of electro-smog: the gravity-electric converters allow for a coupling with the cosmic gravitational background field, while modulation and demodulation is performed by biologically harmonizing oscillators. This new technology is called G-Com and the goal of the team around Dr. Müller is *"to make G-Com available through the supermarket and avoid a situation where the technology is bought up and put away forever"*.

G-Com is a technical revolution that outdoes every communication equipment developed so far. Therefore powerful interests are at stake before its world-wide distribution can be established. Indeed G-com makes possible:

- **Obstacle-free transmission.** G-Com mobile phones allow for communication across any distance, free of charge and without any time delay. Because G-Com transmission is not based on electromagnetic waves but on the modulation of gravitational/pressure standing waves, it does not know any obstacle: it will work underground, through any material, through any dense medium, underwater, across astronomical distances & structures etc...
- **Non-local communication.** G-Com works from any point on Earth or in the universe. As explained by Dr. Müller: *"Systems in linear space located very far from each other can be lying very close to each other within the log space of scales. Our sun and Alpha Centuri are 4 LY (light-years) apart in linear space, while they are neighbors in log space."* Following a successful experiment in January 2002, the provisional analysis by the IREF is that *"a global superluminal communications network is already in place in the universe or the galaxy."* At the School of Sacred Geometry, we call it the "Gala-Net".
- **Iso-chronous technology.** The time lag of transmission is negligibly small because G-Com works in "logarithmic", fractal space, not in the usual space of electro-magnetics. In contrast to conventional telecommunications, G-Com technology does not use radio waves that propagate at light speed from A to B, but standing gravitational waves: the G-Com channel is already in place long before transmission begins and is only being phase-modulated.
- **Pollution-free transmission.** G-Com tech does emit any harmful radiation i.e. it is *electrosmog-free*. No transmitter tower needed. Everyone enjoys telecommunications but people are increasingly concerned by the damaging, direct and indirect, effects of electric pollution. The increasing ubiquity of cell-phones and other electronic devices and the coverage of their transmission fields is life and civilization threatening, however big the corporate denial may be. Electronic fields radiating from current communication tech are NOT optimized according to the the knowledge of Global Scaling harmonics and the latest findings of cutting-edge biology about biologically relevant frequencies. The knowledge of the frequencies that are healthful or harmful for life or people and their various entrainment effects is a whole new science (from wave genetics to wave psycho-sociology) that is "top secret" as it is used by military agencies. Commercially developed electronic fields, arbitrarily chosen, deform and drown the natural background field: they act on our cells like interference signals since they are not ATTUNED to the natural frequency patterns to which all biological organisms on earth have adjusted over many millions of years. Quoting the IREF: *"The problem is that frequencies for information transmission are being sold, bought & licensed without heed of the natural electro-magnetic background. Natural (and gravitational) energies cannot be sold or acquired and therefore cannot be monopolized."*

Let us all educate ourselves and support the coming era of energy and information transmission based on the universal harmonics, as foreseen by such geniuses as Nikola Tesla, Viktor Schauburger and many others.

## SG203.6.4.4 Scale Invariance (4) Hamein-Rauscher Scale

in their 2008 paper *Scale Unification A Universal Scaling Law For Organized Matter*, Nassim Hamein, Michael Hyson and Elizabeth A. Rauscher have collected data about resonance rates in the universe and plotting them against size, from lowest size (the Planck's length =  $10^{-35}$ ) all the way up to the largest cosmological sizes. Comparing then frequencies, they found astonishingly coherent results.

If the universe was simply a randomly evolved collection of matter and energy as still believed by the scientific materialist established paradigm, there would be no relationship at all. But if there was an underlying unity or wholeness, then there would be some sort of relationship. Comparing then frequencies, Hamein et al. found astonishingly coherent and "golden" results.

The graph shows an almost straight-line relationship. →

On the vertical axis of the graph is the frequency (rate of vibration), from highest at the top to lowest at the bottom.

On the horizontal axis is the radius of the object, from lowest to highest. At the top left is the Big Bang itself: a condition whereby all of the energy of the universe was crunched into a tiny primordial seed, called a *singularity*: this is the smallest object with the highest rate of vibration. At the bottom right of the graph is the very largest object (marked "U" on the graph, for universe), which has the lowest frequency.

When the data points on this graph are analyzed, they demonstrate the Phi relationship:  $BB-U / BB-S :: A-U / U-S = \Phi$

$$BB-U = 1; BB-S = 1/\Phi = .618$$

$$A-U = 1; U-S = .618$$

What Hamein et al. have not shown on this graph is the position of the human cell. It is right in the middle of the graph (at the 10" line and marked "C") between "A" (atomic nuclei) and "S" (stellar). The human cell resonates at the frequency of about  $10^{11}$  Hz (cycles, or vibrations, per second). Thus, this graph not only shows the holistic relationship between matter and energy in the universe, but it places life at the very center of the process. We are the interface between the micro and the macro. Hamein and Rauscher refrained from plotting the biological data point in the center of the graph, because it would seem controversial to the mainstream physics community.

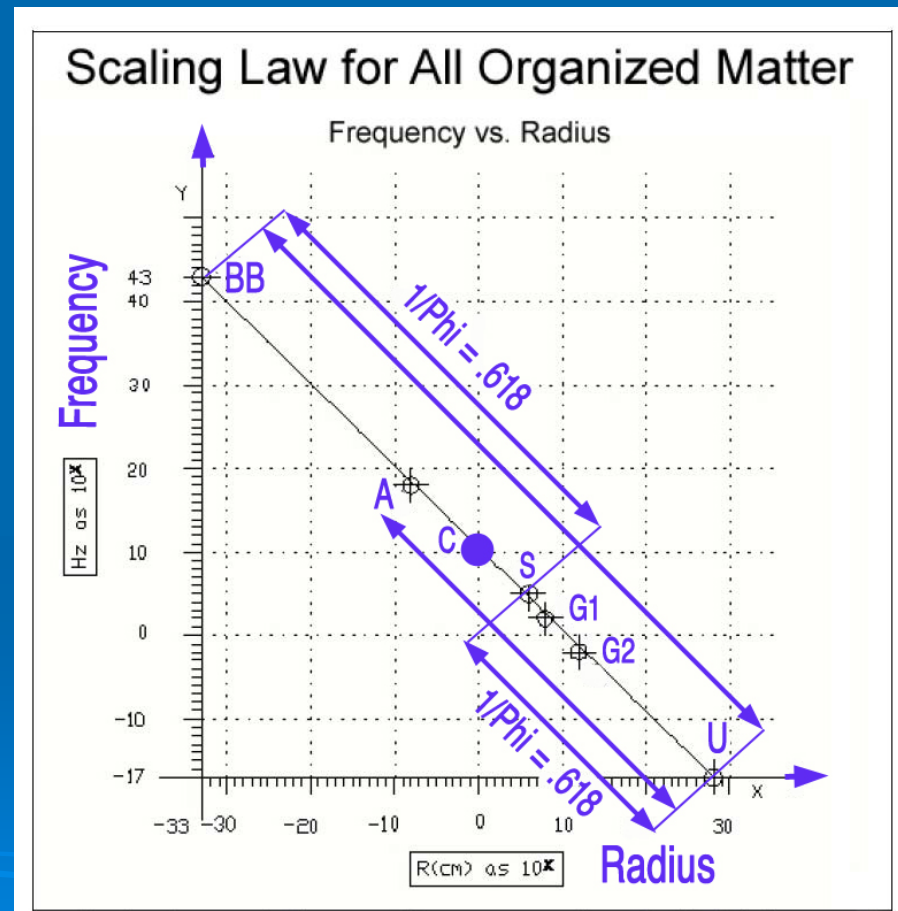

↑ Hamein-Rauscher Universal Scaling Law.  
The blue dot corresponds to the human cell.



## SG203.6.5 A Cosmos of In-Formation

In the new scientific paradigm of the universe as a coherent, inter-connected, scale-invariant entity, the concept of INFORMATION become primordial. Information, on a cosmic scale, is beginning to be seen as all-pervasive and more fundamental than matter, energy or space and time. Transmitting coded information, through holographic wave-interference super-positions, may even be the very purpose of the ZPF or Vacuum/Plenum Field. Are we seeing, on a new turn of the evolutive spiral, a re-discovery of the Akasha, the all-pervasive space of Hindu metaphysics, the location of the "Akashic Records"?

One of the most important aspect of waves is that they encode and carry information. When two waves phase conjugate, they create positive interference and exchange information: in fact, each wave contains all the information of the other. Interference patterns constantly accumulate information, in fractal and holographic ways that equip waves for a virtually infinite capacity of storage.

Information is emerging as the basic feature of nature - and therefore of physics. Moreover, it may well be an active factor that connects phenomena and informs their behavior. Physicist David Bohm (1917-1992) introduced the term "in-formation". In his book (co-written with B. Hiley) *"The Undivided Universe: An Ontological Interpretation of Quantum Theory"* (1993), Bohm explains that quantum processes - by which a determinate physical outcome emerges out of a multiplicity of potentialities - are accounted for in reference to a holographic field carrying active in-formation. In this context, "in-formation" does not involve conventional (vectorial) energy, but the more subtle influence of scalars (torsion waves) that affect phase only. "This creates information of a particular variety: one that is physically effective without conveying manifest energy - it "in-forms" the system receiving it.

As explained by Ervin Laszlo in *The Connectivity Hypothesis* (2003): *"Bohm's concept was anticipated by Einstein with his 'Guidance Field' (Führungsfeld) as a non-energetically in-forming field, governing the motion of particles in space-time. Although Einstein came close to incorporate this concept into his unified theory, he opted instead for the geometry of space-time to guide the motion of particles... However Einstein did note that the concept of a 'physical real ether' must be re-introduced in the worldview of physics, and his insight is now gaining validity."*

Bohm's concept of a non-vectorially propagating "in-formation" has been found to exist beyond the quantum scales, and to be a factor in the evolution of the living world, consciousness and the universe as a whole. Many cutting-edge scientists are following on the steps of Einstein and Bohm and are exploring the fundamental role of in-formation and information coding fields, in a wide range of scientific domains. Among the pioneers: Harold Puthoff, (ZPF), Roger Penrose (Role of Consciousness), Fritz-Albert Popp (Bio-photon Emission), Laszlo Gazdag (re-interpretation of General Relativity), Hans Primas (Psycho-bio-physics), Marco Bischof (Integral Biophysics)...

*"What would emerge would be an increased understanding that all of us are immersed, both as living and physical beings, in an overall inter-penetrating and inter-dependent field in ecological balance with the cosmos as a whole, and that even the boundary lines between the physical and the 'meta-physical' would dissolve into a unitary viewpoint of the universe as a fluid, changing, energetic, informational cosmological unity."*

Harold Puthoff

# SG203.6.6.1 The Field (1) Science in a New Context

The various new faces of the scientific cosmos are all pointing to the re-discovery of an ancient knowledge that is currently dusted off and fast updated: there is a primordial fabric of "space", an inexhaustible ocean of energy & information, a matricial womb, an inter-connective web that produces, codes and contains the universe. This FIELD, at the roots of reality, is a *primordial physics* (etymologically, the knowledge of that which produces & grows = nature) which encompasses both material physics and meta-physics. Yes, this Field welcomes and is based on consciousness. The best, simplest and most efficient explanation for the many anomalies that are not accounted for by the Standard Model of science is the existence of a larger (higher-dimensional) CONTEXT providing the all-scales coherence, all-inclusiveness, non-local inter-connectivity that we observe across the board of our contemporary scientific experimentation.

Described by a long tradition of mystics, seers, philosophers and ancient scientists under the names of Chi, Prana, Akasha, Life Force, Holy Spirit, Baraka, Mana, Ether etc..., this Field was denied by late 19th century science due to some misinformed experiments (see further). 20th century science, including classical quantum physicists, deepened the separation and the specialization: Niels Bohr hung a sign on his door saying: "Philosophers keep out. Work in progress." Even though human consciousness was discovered to be key to the quantum flux to manifest into set reality, there was no pursuit of the field implications of quantum mechanics: the quantum phenomena were kept confined to the sub-atomic levels; macro-scale reality was still thought to obey the normal rules of physics.

This has all changed in the last 30 years. Pioneer scientists picked up where quantum physics had left off and reintroduced the equations for the Zero Point Energy Field (ZPF) - an ocean of microscopic vibrations in the space between things. They realized that, underpinning our universe, there was a tremendous sea of energy-information: the quantum foam or field that provided an interconnecting web for everything. Eventually, experiments showed that, at the macro-scale, we as human beings were also governed by information exchanges based upon quantum-type processes: cell communication, DNA coding, metabolism, feeling, higher cognitive functions such as a perception... are displaying a supra-coherence due to a high level resonance with the Zero Point Field.

The "vacuum fluctuations" of the ZPF and its coherence fields, which are now thought to constitute the inner physics of life and all creation, are usually not directly measurable but are mathematically reproducible. "Vacuum Coherence Physics" (VCP) is based upon harmonic wave interaction - not upon thermo-dynamic (explosive & belligerent) interaction. In this new "non-linear" physics, geometric patterns or pulses are essential. They are the cause of the "non-locality" of life force and self-awareness and in the material world also the cause of the known forces. The two most definite inner figures of this geometric vacuum flux are:

- The Golden Mean ("Phi" = 1.618... and  $\sqrt{5}$  number systems) based geometries, which is the universal constant of fractal, implosive, proportional scaling and the super-attractor for self-similarity and the harmonic recursiveness factor of the golden vortex. The 3D representatives are the phi-based, penta-symmetric two higher Platonics: the Icosahedron and the Dodecahedron and their higher-dimensional polytope parents.
- The Octave based geometries ( $\sqrt{2}$  and 4 number systems) which is the non-linear equivalent of arithmetical addition. The representative figures are the triangle/tetrahedron, cube and octahedron.

*"In its macroscopic manifestation, the Vacuum-flux exists in a state of increased coherence among vacuum fluctuations. The emerging, actual "energy" flows of life force and self-awareness are entirely self-contained (self-referring or recursive) and therefore have no net measurable effect. The flux of these geometries, endlessly being created and destroyed, is the primordial state of the Vacuum. The Vacuum is a 'Plenum'."*



## SG203.6.6.2 The Field (2) Field Experiments

How has the ZPF been lately re-confirmed?

In the Grand Unified Theories (GUTs) developed in the late 20th century, the vacuum is conceived an underlying background *medium* carrying the Zero Point Field (ZPF). The name "zero-point" was coined because when all classical forms of energy disappear, at the temperature of absolute zero, energies still prove to be present in the "vacuum". Indeed, the ZPF effects can be observed in various phenomena now proven and many more interactions are coming to light and are under current investigation.

- **Spontaneous emission of light or luminescence.** Process by which a light source (atom, molecule...) undergoes a transition from an excited state into the ground (or Zero-Point) state and emits a photon. This is a fundamental process playing an essential role in many phenomena in nature and technology.
- **Lamb Shift.** In 1947, Willis Lamb (1955 Nobel Prize) measured a small difference in energy between two levels of the hydrogen atom. This frequency shift is due to the interaction between the electron and the ZPF. The *Lamb Shift* was the forerunner of Quantum Electrodynamics.
- **Casimir Effect.** In 1948, Dutch physicist Hendrick Casimir predicted the existence of a tiny attractive force between closely placed metal plates due to resonances in the vacuum energy in the space between them. This is now known as the *Casimir Effect* and has since been extensively experimentally verified. This proved that the "vacuum energy" is "real" in the same sense that a magnetic field is real. The van der Waals Effect, similarly, proved interaction with the ZPF.
- **1950s & 1960s Russian Research.** The pre-eminent Russian astrophysicist Nikolai A. Kozyrev conducted many experiments to prove the existence of a "physical vacuum" which he linked to the "spiraling flow" of time. This led, in Russia and later in the West, to an extensive study of "torsion waves" (also called *scalar waves*) and the *torsion wave linking* property of the ZPF. Dr. Kozyrev devised many experiments (with gyroscopes, pendulums and torsion wave balances) to create "anomalous" effects that can only be explained by the ZPF. In the 1960s, Andrei Sakharov proposed that gravity and relativistic phenomena are the results of effects induced in the vacuum due to the shielding of the ZPF by charged particles.
- **1960s. Paul Dirac** showed that fluctuations in fermion fields (*fermions* are the 12 known fundamental particles) produce a polarization of the ZPF of the vacuum, whereby the vacuum in turn affects the particles' mass, charge, spin or angular momentum.
- **Vacuum Vortices.** Laszlo Gazdag has argued that vacuum-based vortices record information on the state of the particles that created them - and their interference pattern records information on all the particles with which the vortices have interfered.
- **1987. Hal Puthoff.** In his classic Physical Review paper, Puthoff showed that the stable state of matter depends on the dynamic interchange of subatomic particles with the sustaining ZPF: electrons "refuel" from the vacuum fluctuations. And so with planets and solar systems constantly replenishing their lost momentum from the ZPF.
- **Vacuum Structuring.** Kozyrev and others (Donald Roth in the West) documented a form of "vacuum memory" now called "Vacuum Structuring".
- **Aspden Effect.** In 1995, Dr. Harold Aspden spun a permanent-magnet rotor up to its rated speed. He found that if the rotor is brought to rest and spun up again within a minute after stopping, it required only 30 Joules to bring it to the same speed as compared to 300 Joules for the first attempt. The importance of this experiment is that it strongly points to a medium that is affected by the first spin and which in turn affects the second spin.

*As a temporary conclusion, we can observe that:*

1. *the ZPF (quantum vacuum) has progressively become a full-time resident of current science. The ZPF is now recognized as a super-dense cosmic medium carrying light, the universal forces of nature, density-pressure & torsion waves... and "holographically-embedded" information.*
2. *Besides giving a simpler explanation than the endless renormalizations of the GUTs, the ZPF offers a existential relief: we, as matter-energy-information-consciousness, are inter-connected throughout the entire cosmos through the ZPF. We are indeed ONE, as spiritual wisdom has always claimed.*
3. *The ZPF is the first emerging common ground between science and spirit traditions.*

## SG203.6.6.3 The Field (3) Returning Home

### The Michelson-Morley Experiments

When the topic of the ZPF or "Cosmic Field" comes up, well-meaning scientist types never fail to bring up the : "MM experiments" performed in the 1880s.

The experiment was designed to detect the presence of the "luminiferous aether" concept popular at the time. It consisted of measuring the time of travel of light when the aether, or carrier of light, was moving towards or away from the observer. The time should be different in the two cases, in a similar way that waves on the surface of water would be affected by the movement of water that carries the waves.

The outcome of this experiment was an apparent null result. That is, the times of travel were the same, suggesting there was no aether carrying the light waves. From that time on, mentioning a "universal medium" became a taboo subject in the hallways of standard science.

However, as pointed out by further researchers, Michelson & Morley assumed a *stationary* medium whereas an *aether entrainment model* (i.e. the Earth entrains the medium causing it to rotate along) is supported by recent research such as the light & radio interferometry work of Yuri Galaev (Ukraine, 2001).

Richard Feynman is quoted as saying:

*"The energy in a single cubic meter of space is enough to boil all the oceans of the world".*



For an extensive (and archived) library of articles & references about the ZPF and aether, go here:

[www.mountainman.com.au](http://www.mountainman.com.au)

Human consciousness goes through amazing evolutionary loops: whereas an "Ethereic field" of subtle energy has been taken for granted by all ancient sacred cultures and was, up to the latest part of the 19th century, a scientific fact, it suddenly disappeared from the front scene of the western culture for almost a century.

To be sure, non-conformist science luminaries and visionaries such as Nikola Tesla, John W. Keely, Viktor Schauberger or Wilhelm Reich kept the tradition of the "field" going. Tesla spoke of an "original medium" that fills space: in his 1907 paper "Man's Greatest Achievement", he explained that since this medium fills all space, everything that takes place in space can be referred to it. The curvature of space, said Tesla, which was put forward at the time by Einstein, is not the solution. (Quoted from Ervin Laszlo. *Science and the Akashic Field*. 2004)

The ZPF has made a strong comeback and is now considered to be the home (both repository and source) of all fields: a mother-field or meta-field.

In 1994, B. Haish, A. Rueda and H. E. Puthoff published a paper in the Physical Review about "Inertia as zero-point Lorentz force". The paper showed that the property of *inertia* showed by all objects in the physical universe was simply resistance to being accelerated through the ZPF. As explained by Lynne McTaggart in *The Field*, this means that the *matter* (to which all physicists since Newton have attributed an innate mass) was an ILLUSION. Matter is not a fundamental property of physics.

Arthur C. Clarke predicted that the above 1994 paper would one day be regarded as a landmark. In *3001: The Final Odyssey*, Clarke wrote: *"It addresses a problem so fundamental that it is normally taken for granted, with a that's-just-the-way-the-universe-is-made shrug of the shoulders. The question HR & P asked is: 'What gives an object mass (or inertia) so that it requires an effort to start it moving, and exactly the same effort to restore it to its original state?'*

*Their provisional answer depends on the astonishing and - outside the physicists' ivory towers - little-known fact that so-called empty space is actually a cauldron of seething energies - the Zero Point Field... HR & P suggest that both inertia and gravitation are electromagnetic phenomena resulting from interaction with this field."* In *3001*, Clarke created a spacecraft powered by an inertia-cancelling drive known as the SHARP (an acronym for Sakharov, Haisch, Alfonso Rueda and Puthoff).

In 1995, Haisch et al. published a paper showing that the universe owes its very structure to the ZPF.

The current understanding of the ability of the ZPF to encode information through superposition of wave interference, and to provide instantaneous communication by quantum resonance with all parts of the universe (including human consciousness) IS the foundation of the new scientific paradigm.

# SG203.6.7 A Cosmos of Intention & Consciousness

As the new faces of the next paradigm of science become more familiar, an increasing number of scientists are developing experiments to document the active role of human intention and consciousness in the shaping of cognition and reality. Various physicists are working on unified theories where consciousness, and not matter, is the ground of the universe and possibly the fabric of the ZPF.

In her ground-breaking book "The Field", Lynn McTaggart gives documented updates on the following research projects, all showing strong correlations for conscious intention:

- SRI "Remote Viewing" data under the direction of Harold Puthoff and Russell Targ.
- Brenda Dunne & Robert Jahn PEAR project: data on "Remote Intention" and "Retro-Cognition".
- William Braud data. Braud built upon the classical 1960s studies on telepathy and proceeded to demonstrate the "Effects of Intention on Human Cells".
- The "Collective Consciousness Intention" data gathered by Dean Radin and published in his book "The Conscious Universe", 1997.
- The "Distant Healing" data of Dr. Bernard Grad, Randolph Byrd, Elizabeth Targ & Fred Sicher, and the MAHI study.

McTaggart sums up stating: *"It seems we have an ability to extend out our own coherence out into our environment... The "Field" allows us to see the whole universe inside us"*.

In 2001, Stanford University Professor William Tiller and two co-authors published their research supporting the evidence that human consciousness contributes to the creation and direction of the universe. For the first time, the argument has been put in the language of rigorous physics, backed by solid experimental data. We quote from the Preface to the book:

*"For the past several centuries and up to the present day, the formal expressions from the various sub-fields of physics have contained no contributions arising from any human quality - as if the various human 'broadcast - fields' in no meaningful way interacted with the substratum for nature's modes of expression... This book demonstrates, utilizing a unique experimental protocol (IIED or Intention Imprinted Electrical Device) on both inanimate and animate systems, that the human quality of focused intention can be made to act as a true thermodynamic potential and strongly influences experimental measurements for a variety of specific targets... In addition, continued use of this protocol in a given experimental locale leads to a unique conditioning of that space (whereby) the local physics Gauge symmetry is raised to a higher level." (In other words, human intentions imprint themselves in the space surrounding them - think of "sacred spaces").*

*"Such remarkable changes appear to be related to transformations of the vacuum substance within each atom and molecule occupying that cognitive space..... This heralds an exciting era of new science, technology and human self-realization... a much greater vista filled with great new adventures for questioning minds.*

*"It seems abundantly clear that consciousness-directed intention is a powerful force that must be incorporated into any new scientific paradigm." Tiller.*

## CONSCIOUS ACTS OF CREATION THE EMERGENCE OF A NEW PHYSICS

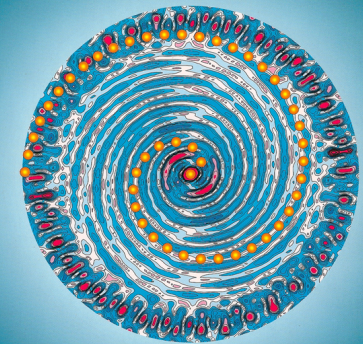

William A. Tiller, Ph.D.

Walter E. Dibble, Jr., Ph.D.

Michael J. Kohane, Ph.D.



# SG203.6.8.1 Golden Ratio in the Quantum World (1)

Researchers from the Helmholtz Center (HZB, Germany), in cooperation with colleagues from Oxford and Bristol Universities, as well as the Rutherford Appleton Laboratory, UK, have for the first time observed a nanoscale symmetry hidden in solid state matter. They have measured the signatures of a symmetry showing the same attributes as the *golden ratio* famous from art and architecture.

[Here is the news release from the HZB Center \(January 7th, 2010\):](#)

When applying a magnetic field at right angles to an aligned spin the magnetic chain will transform into a new state called quantum critical, which can be thought of as a quantum version of a fractal pattern.

Prof. Alan Tennant, the leader of the Berlin group, explains: *'The system reaches a quantum uncertain - or a Schrödinger cat state. This is what we did in our experiments with cobalt niobate. We have tuned the system exactly in order to turn it quantum critical.'* By tuning the system and artificially introducing more quantum uncertainty the researchers observed that the chain of atoms acts like a nanoscale guitar string.

Dr. Radu Coldea from Oxford University, who is the principal author of the paper and drove the international project from its inception a decade ago until the present, explains: *'Here the tension comes from the interaction between spins causing them to magnetically resonate. For these interactions we found a series (scale) of resonant notes: the first two notes show a perfect relationship with each other. Their frequencies (pitch) are in the ratio of 1.618, which is the Golden ratio famous from art and architecture.'* Radu Coldea is convinced that this is no coincidence: *'It reflects a beautiful property of the quantum system - a hidden symmetry. Actually quite a special one called E8 by mathematicians, and this is its first observation in a material'*, he explains.

More information: Quantum Criticality in an Ising Chain: Experimental Evidence for Emergent E8 Symmetry. Article in *Science*, DOI:RE1180085/JEC/PHYSICS  
R. Coldea, D. A. Tennant, E. M. Wheeler, E. Wawrzynska, D. Prabhakaran, M. Telling, K. Habicht, P. Smeibidl, K. Kiefer.

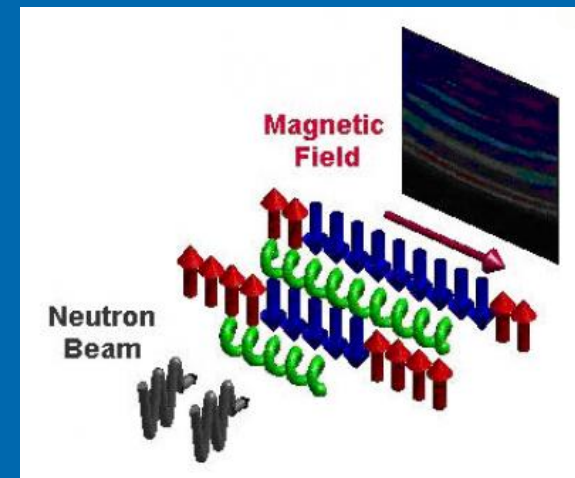

↑ The magnetic field is used to tune the chains of spins to a quantum critical state.

The resonant modes ("Notes") are detected by scattering neutrons. These scatter with the characteristic frequencies of the spin chains.

# SG203.6.8.2 Golden Ratio in the Quantum World (2)

Some web comments & implications on this discovery... Quotes from: [www.news.softpedia.com](http://www.news.softpedia.com)

January 21st, 2010.

After the experimental discovery of the golden mean in quantum mechanics there is no room anymore for conventional skepticism... The golden mean was discovered in relativity by Sigalotti. It is the basis of the first rational explanation of the two slit experiment by the Egyptian Mohamed El Naschie. It underpins high energy physics as discussed by Slovenian Crnjac, Chinese Ji Huan He as well as many of their associates. El Naschie presented the first complete theory of unification based on golden geometry and golden quantum field theory. Golden geometry and topology was developed in Romania by two mathematicians. The recent magnificent book by a noted Soviet scientist Alexei Stakhov [SG203.4] bears witness for the reality and theoretical soundness of the golden mean quantum mechanics.

February 4th, 2010.

There is a highly interesting connection between science and religion which comes out as a by-product of El Naschie's discovery of golden mean geometry and quantum golden mean theory.

For a few hundred years facts and values were separated. Science is the world of facts. Morality and art is the world of values. Since Islamic science and later on Francis Bacon, the scientific method dealt only with facts. Anything dealing with values was called philosophy or religion even when facts are also involved. Needless to say art, music, emotions and beauty are all things related to values. It follows then that the golden mean which was used by the Egyptians, the Greeks and the Renaissance artists is a fundamental tool in the world of values. It is fundamental to art and consequently emotions, morality and religion. It has something to do with good and bad. You cannot give a definite objective reason for something being beautiful. Never the less we know and feel the beauty of a golden mean composition whether it is in the visual or audio arts.

Here comes then the surprise. To discover the golden mean as the basis of quantum mechanics is tantamount to discovering that there is a bridge between the world of values and the world of facts. The experimental confirmation of the golden mean in quantum mechanics and the basic correctness of Mohamed El Naschie's theory of Cantorian spacetime, which is based on the golden mean, is an irrefutable proof of what people sensed long ago but were not able to demonstrate in a mathematical way, namely that *art, religion, mathematics and natural science are somehow deeply interconnected*. The experimental work at the Helmholtz Inst. in Germany and the theory of El Naschie and his colleagues is a radical departure from an old paradigm which lasted for over a thousand years. We can no longer claim that there is no connection between love and reason or emotions and facts.

We do not yet have a complete proof. We are not even at the beginning. However with El Naschie's theory experimentally confirmed, we may be at the beginning of the beginning of a new era in science, philosophy, art and religion.

February 6th, 2010.

How does the golden mean enter into quantum mechanics? The answer is as simple as it is ingenious. Mohamed El Naschie reformulates quantum mechanics in spacetime following the same concepts used by Richard Feynman as well the classical work of Einstein. Since the building blocks of spacetime are his elementary random Cantor sets and because these random Cantor sets possess the golden mean as a Hausdorff dimension, the golden mean slips into the fundamentals of quantum mechanics. Nothing that quantum mechanics is the most fundamental theory upon which science is based, *the golden mean could rightly be described as the basis of science*.

February 13th, 2010.

Mohamed El Naschie is the first to discover the golden mean as the basis of quantum mechanics.

The idea follows in a trivial way from the fact that fractal trees neither overlap nor leave gaps only for a golden mean scale.

## SG203.6.9.1 E-Infinity (1) Meet M. S. El Naschie

M. S. El Naschie is a maverick mathematical physicist, with a background in engineering, who is known for his *E-Infinity Theory*, sometimes also called *Cantorian Space-Time*. E-Infinity is the first theory that makes use of the concepts of Cantor set and Golden ratio in high energy physics. The theory successfully predicted the accurate values of mass spectrum of elementary particles, viewed as "*non-complex functions of the golden mean and its derivatives*".

The founder and long time editor (now retired) of the journal *Chaos, Solitons & Fractals*, El Naschie had a career spanning Germany, Great Britain and Egypt. El Naschie has published over 300 scientific papers.

The E-Infinity theory presents the Golden Ratio as the "*winding number*" in the harmonic manifestation of quark & subatomic particle masses. In the words of El Naschie, particle physics appears as a "*cosmic symphony*" and the values of quark masses form a "*harmonic musical ladder*".

Says El Naschie: "*The appearance of the Golden Mean as the frequency of vibration and mass-energy factor.... indicates that it is the simplest realistic unit from which a Hamiltonian dynamics can start developing a highly complex structure, a so-called nested vibration... The Golden Mean plays a decisive role in non-linear dynamical stability, chaotic systems and high energy particle physics... by creating the most stable periodic orbit due to being the most irrational number, according to the chaos border KAM theorem... Since the Golden Mean is the most irrational number, the corresponding orbit is the most stable orbit.*"

*To observe a particle, the corresponding vibration must be stable and that is only possible in the KAM interpretation which we call the VAK Cantorian theory of vacuum fluctuation, when the winding number corresponding to this dynamics is equal to the Golden Mean."*

Lately, a large-scale defamation campaign was launched against M. S. El Naschie by self-appointed "guardians of science", first involving the journal Nature and magazine Die Zeit, then a prime defamatory article followed by an onslaught of blog "debunking" of the vilest nature, calling El Naschie a crank and a numerologist, in the absence of any scientific debate. The original articles have now been withdrawn. Yet, in a culture made by the lowest denominator of the media, damage was done to the name of a respected international scientist, to scientific research itself and specially to the re-emergence of the "Golden Ratio" as a universal constant. The "anti-Phi" lobby seems increasingly desperate.

Note: a similar defamation was applied to the work of Dan Winter, a decade ago.



M. S. El Naschie

### Associate and Follow-up Research

What is now called the "*Fractal-Cantorian space-time community*" has a rich historical context:

- Early research: Felix Klein (group theory), Sophus Lie (Exceptional Lie Groups), Wilhelm Killing & Elie Cartan (Lie group E8 algebra, the basis for heterotic super string theory and E-infinity). Emily Noether (Noether's Theorem, a central result in theoretical physics). Georg Cantor (Cantor Set).
- 1960s. Donald Coxeter (Coxeter polytopes)
- 1960s. KAM theorem (maximum irrational frequencies).
- 1983. G. Ord coined the term "Fractal space-time".
- 1990. El Naschie: Cantorian version of spacetime.
- 1993. Laurent Nottale: scale relativity theory.
- 1995. Prigogine, Rössler & El Naschie edit book on basic principles of fractal space-time.
- 1998. Mauldin & Williams. Cantor Hausdorff dim. =  $1/\Phi$
- 2000s. G. 'tHooft: holographic principle in quantum gravity.
- 2000s. Exceptional Lie groups & Stein space hierarchy. Transfinite scaling transformation. Kähler manifolds.
- 2000s. Development of E-infinity Theory by El Naschie.
- 2000s. E<sup>∞</sup> research: Ji-Huan He (China), G. Iovane (Italy), Leila Marek-Crnjac (Slovenia)...
- 2007. Mapping of the 248-dimensional matrix of E8.
- 2008. Garrett Lisi: E8 Theory of Everything.
- 2008. Computer simulation of quantum space-time. Loll & al.



## SG203.6.9.2 E-Infinity (2) Introduction

In an email response to Dan Winter (published [here](#)), El Naschie gives a clear delineation of his work:

*"If we start by rabbits, camels, dogs or any configuration and go on reducing it in size indefinitely by splitting each camel into three camels and take one of these camels out of our set, then we end up in all events with a cantor dust. It makes no difference what we start with. The differences between the objects will disappear in the limit. In fact we could start with President Bush or Obama and we will end in all events with the same Cantor dust. If our process is random and we use uniform distribution, then the Hausdorff dimension of the cantor dust that we obtained will be equal to the golden mean. Two Americans proved this theorem namely, Mauldin and Williams.*

*By pure coincidence I proved the theorem in four dimensions and later on realized that I generalized Mauldin-Williams theorem without knowing. That was the start of my work. The Hausdorff dimension of a 4-dimensional cantor set is necessarily equal to  $1 + \text{the golden mean all to the power of } 3$ . This is exactly equal to  $4 + \text{the golden mean to the power of } 3$  which is exactly equal to 4.236067989. Please work it out yourself.*

*Interestingly, this Hausdorff dimension lives inside a smaller dimension, namely exactly 4. Four is the topological embedding dimension. It is similar to a melon. The outer surface is smooth and the dimension is 2. But the inside of the melon is non-smooth and the dimension is more than 2. The whole object is of a dimension equal to 3. Similarly, our spacetime, I reasoned much later, has a topological dimension equal 4 and a Hausdorff dimension equal to  $4 + \text{the golden mean to the power of } 3$ . And the whole thing can be embedded in different ways including  $5 + 5$  to the power of 3 dimensions and so on...In fact we can reach the dimensionality of electromagnetic field that way which is equal to 20 multiplied by  $1 + \text{plus Phi all to the power of } 4$ . This gives exactly 137.082039325.*

*We can go on reasoning things in a similar but more complex manner until we reach the conclusion that Newton's dimensionless gravity constant is equal to  $2$  to the power of the inverse electromagnetic fine structure constant (the one I have just mentioned) minus ten which gives approximately ten to the power of 38 as is well-known experimentally. The theory from which I obtained all the result I named E-Infinity theory and when specializing it to quantum field theory, I call it **quantum golden field theory**."*

*"The Exceptional E8 Lie Group could be constructed (by nesting) from two 600-cell Coxeter polytopes. The result is what we call E8 Gosset. In other words, the E8 exceptional Lie symmetry group, similar to all the five members of the exceptional family, are based on Golden Mean proportioned Gossets. Our theory is thus deeply related to the work of Luminet on well proportioned spacetime manifolds and his Poincaré dodecahedron."*

# SG203.6.9.3 E-Infinity (3) Phi in Particle Physics

EI Naschie's  $E^\infty$  theory successfully predicted the accurate values of mass spectrum of elementary particles, viewed as "non-complex functions of the golden mean and its derivatives".

The  $E^\infty$  values for some constants are:

- "Alpha Bar" =  $20 \Phi^4 = 137.0820\dots$  This is the  $E^\infty$  derived *inverse electromagnetic fine-structure coupling constant* discovered by Sommerfeld in 1916 to explain the spectral lines of hydrogen radiation. Wolfgang Pauli was fascinated by the fine structure constant and had dreams about it to the point that he and Carl Jung corresponded extensively about the interpretation of "137".
- Alpha bar "gs" is the inverse coupling constant "at the super symmetric unification of all fundamental forces taking place at the Planck's length of  $10^{-33}$  cm."

subatomic particle	theoretical mass (MeV)	experimental value (MeV)
e (electron)	$\sqrt{\alpha_{gs}}/10 = \sqrt{(10 \Phi^2)}/10$ = 0.51166...	0.511
n (neutron)	$20 \Phi^8$ = 939.574...	939.563
P (proton)	$20 \Phi^8 \cos(\pi/60)$ = 938.28...	938.27231
$\Pi^\pm$ ( $\Pi$ meson)	$\bar{\alpha}_0 + (5/2)$ = 139.5820...	139.57
$\Pi^0$	$\bar{\alpha}_0 - (5/2)$ = 134.5820...	134.98
$\Omega^-$	$10[\bar{\alpha}_0 + (49/\Phi)]$ = 1,673.657...	1,672.43

↑ Some subatomic particle mass as a function of  $\Phi$  and  $1/\Phi$ .  
From Scott Olsen. *The Golden Section*.

Quark Flavor	Current Mass (MeV)	Constituent Mass (MeV)
Up	$2 \Phi^2 = 5.236$	$80 \Phi^3 = 338.885\dots$
Down	$2 \Phi^3 = 8.472\dots$	$80 \Phi^3 = 338.885\dots$
Strange	$10 \Phi^6 = 179.442\dots$	$10 \Phi^8 = 469.787\dots$
Charm	$300 \Phi^3 = 1,270.82\dots$	$20 \Phi^9 = 1,520.263\dots$
Beauty/Bottom	$10^3 \Phi^3 = 4,236.067\dots$	$100 \Phi^8 = 4,697.871\dots$
Truth/Top	$104 \Phi^3 = 42,360.673$	$10^4 \Phi^6 = 179,442.719\dots$

↑ Current and constituent quark mass as function of  $\Phi$  and  $1/\Phi$ . From: Scott Olsen. *The Golden Section*, 2006.

## SG203.6.10.1 Raji Heyrovska (1) Golden Ratio in Hydrogen

*"... the energy of atomic hydrogen is actually equivalent to the energy of the simplest atomic condenser with the Golden mean capacity."*

In the last few years, Dr. Rajalakshmi Heyrovska (Raji Heyrovska), at the Prague Academy of Sciences (Czech Republic), has been making amazing discoveries re: the appearance of the Golden ratio in atomic & molecular physics. The important role of the Golden ratio in assigning ionic radii from inter-atomic distances was discovered while interpreting the ground state ionization potential and the Bohr radius of the hydrogen atom.

Heyrovska's "Golden discovery" arose from the author's finding that *"the ratio of the radius of hydrogen, estimated recently (2001) by density functional methods, to the ground state Bohr radius is the Golden ratio, which operates in a variety of natural phenomena. It is found that the Golden ratio indeed plays a quantitative role in atomic physics. The interesting results are:*

- (1) that it arises in atomic dimensions due to the electrostatic forces between negative and positive charges;
- (2) that the energy of atomic hydrogen is actually equivalent to the energy of the simplest atomic condenser with the Golden mean capacity;
- (3) that the origin of two terms in the Rydberg equation for absorption and emission is in fact in the ground state term;
- (4) that all atoms can be assigned definite values of cationic and anionic radii based on the Golden ratio and covalent radii;
- (5) that these radii are additive and explain quantitatively bond lengths like those of alkali halides, of hydrides of many elements and of many other bonds, whether covalent or ionic or both;
- (6) that the work functions of alkali metals can be evaluated using the bond lengths."

Quoting from R. Heyrovska:

*"The ground state ionization energy (EH) of the hydrogen atom is the energy needed to separate the two oppositely charged particles, the electron (e-) and the proton (p+), from each other to ionize the atom. The ionization potential is thus the difference in the potentials at ionization of the electron and proton.*

**The Bohr radius  $a_B$  ( $= a_{B,p} + a_{B,e}$ ) has two Golden sections,  $a_{B,p} = a_B/\phi^2 = 0.382a_B$  and  $a_{B,e} = a_B/\phi = 0.618a_B$  pertaining to p+ and e- respectively.**

### Generalization by Heyrovska:

"It was further shown that the bond length  $d(AA)$ , in general, between any two atoms (A) of the same kind is the sum of the two Golden sections:

$$d(AA) = 2R(A) = d(AA)/\phi^2 + d(AA)/\phi = R(A+) + R(A-)$$

where  $R(A) = d(AA)/2$  is the covalent or bonding radius,  $1/\phi^2 = 0.382$ ,  $1/\phi = 0.618$  and  $R(A+) = d(AA)/\phi^2$  and  $R(A-) = d(AA)/\phi$  are the Golden ratio based cationic (+) and anionic (-) radii, respectively, of A.

This explains the generally known order of the radii,  $R(A-) > R(A) > R(A+)$  for elements."





# SG203.6.10.2 Raji Heyrovska (2) Golden Ratio in Hydrogen

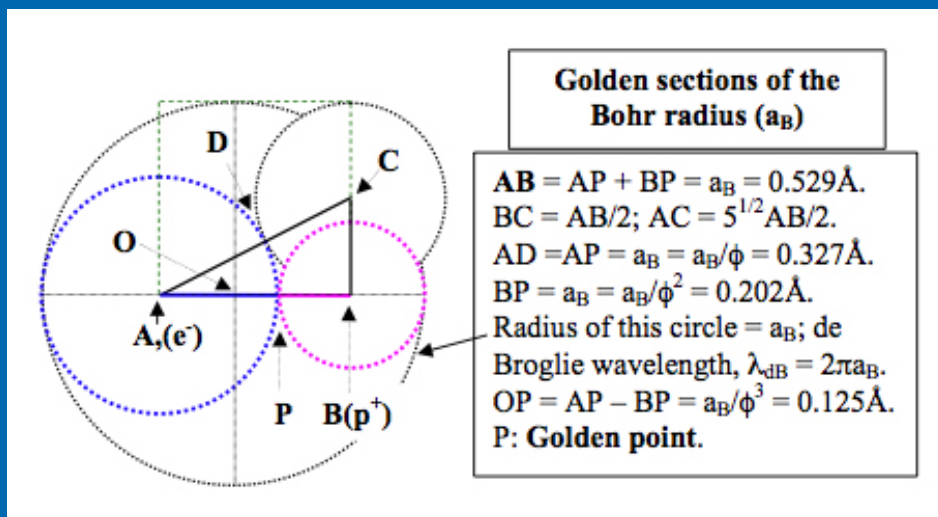

← ↓ Diagrams from R. Heyrovska in her article:

Golden Sections of Inter-atomic Distances as Exact Ionic Radii of Atoms. R. Heyrovska  
<http://precedings.nature.com/documents/2929/version/1>, (2009)

*"Phi arises right at the core of the hydrogen atom"*

R. Heyrovska

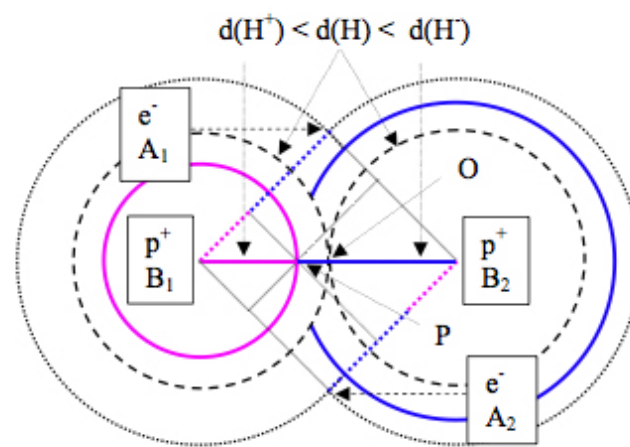

**Golden sections of the H-H bond length in  $H_2$ :**  
 $2^{1/2}a_B = d(HH) = d(H^+) + d(H)$

$A_1B_1 = A_2B_2 = a_B$  (see Fig. 2)  
 $B_1B_2 = d(HH) = 2^{1/2}a_B = 0.74\text{\AA}$   
 $B_2P/B_1P = B_1B_2/B_2P = \phi$ .  
 $d(H) = B_1O = B_2O = d(HH)/2$   
 $d(H^+) = B_1P = d(HH)/\phi^2 = 0.28\text{\AA}$   
 $d(H^-) = B_2P = d(HH)/\phi = 0.46\text{\AA}$   
 $OP = B_2P - B_2O = B_1O - B_1P = d(HH)(1/\phi - 1/2) = d(HH)(\frac{1}{2} - 1/\phi^2) = 0.118d(HH) = 0.087\text{\AA}$ .

# SG203.6.10.3 Raji Heyrovska (3) Golden Ratio in Chemical Bonds

Below are some highlights of the appearance of the Golden ratio gleaned throughout R. Heyrovska's many science articles.

- **Ionic radii in aqueous solutions.** The ion-water (oxygen) distances for ions of monovalent, divalent and trivalent elements including lanthanides increase linearly with the covalent radii of atoms. The slopes and intercepts of the lines are found to depend on the Golden ratio. → The ionic radii in water have been evaluated and ion/water boundaries located. The hydration distances of the oxygen of water to the peripheries of the cations are of four types and are constants. The distance of the hydrogen of water to the peripheries of halogen anions, which is the length of the hydrogen bond, is also a constant.

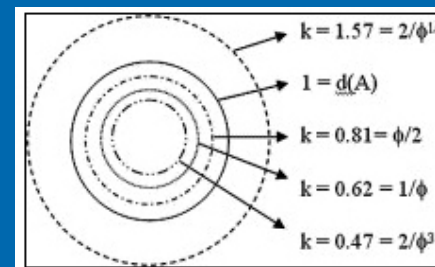

- **In Benzene.** The radius  $R_{r.b.}$  (resonant bond = 0.71Å) is related to the radius  $R_{s.b.}$  (single bond = 0.77Å) and the radius  $R_{d.b.}$  (double bond = 0.67Å) through the Golden ratio ( $\phi$ ) as follows:

$$R_{r.b.} = (R_{s.b.}/\phi^2) + (R_{d.b.}/\phi) = (0.294 + 0.414) \text{ \AA}.$$

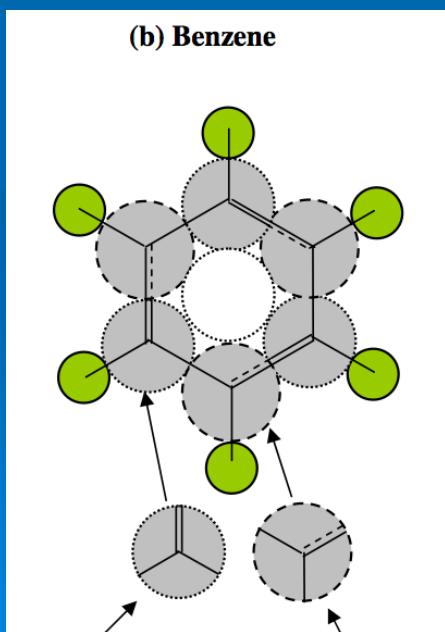

- **Carbon-Carbon Bonds.** (2008.) Various Carbon to Carbon Bond Lengths Inter-related via the Golden Ratio, and their Linear Dependence on Bond Energies.

"The Golden ratio, which was shown to divide the Bohr radius into two parts pertaining to the charged particles, the electron and proton, and to divide inter-atomic distances into their cationic and anionic radii, also plays a role in the carbon-carbon bonds and in the ionic/polar character of those in graphite, butadiene and benzene. Further, the bond energies of the various CC bonds are shown to vary linearly with the bond lengths.

Thus, the CC bond in butadiene can also be considered as an ionic bond... The radius of the butadiene ( $R_{bt.b.}$ ) is related to the radius of the single bond ( $R_{s.b.}$ ) via the Golden ratio:

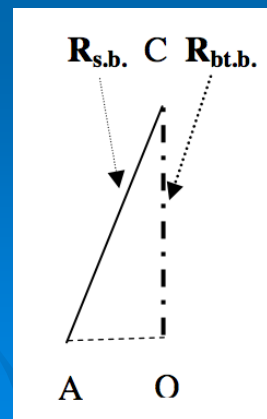

$$\begin{aligned} R_{bt.b.} &= 0.948 R_{s.b.} \\ &= R_{s.b.} \cdot (1 - 1/4\phi^2)^{1/2} \\ &= R_{s.b.} \cdot \cos 18^\circ \\ &= 0.73 \text{ Angstrom} \end{aligned}$$

# SG203.6.10.4 Raji Heyrovska (4) Phi Architecture of Atoms & Ions

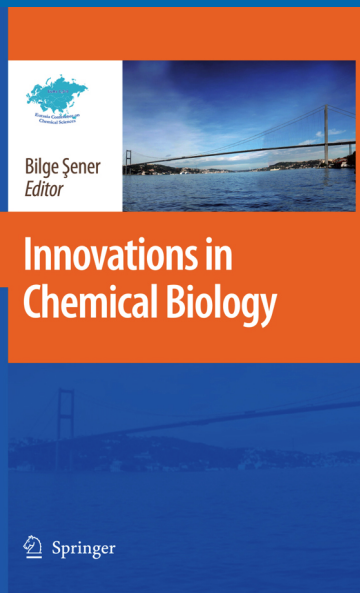

In the book *Innovations in Chemical Biology* (Springer, 2009), R. Heyrovska published a landmark chapter: *The Golden Ratio in the Creations of Nature Arises in the Architecture of Atoms and Ions* (chapter 12).

Here is the abstract:

"The Golden ratio,  $\Phi = a/b = (a + b)/a$ , where  $a$  and  $b$  are the Golden sections of their sum, has long been known to operate in a variety of the creations of Nature, ranging from the mollusks in the oceans to the spiral galaxies in the Universe. Recently, while researching for the exact values of ionic radii and for the significance of the ionization potential of hydrogen, it was found that  $a_B$ , the Bohr radius has two Golden sections pertaining to the electron and proton. Further,  $\Phi$  was also found to be the ratio of the anionic to cationic radii of an atom ( $A$ ), their sum being the covalent bond length,  $d(AA)$ .

With these radii many bond lengths were shown to be sums of the covalent and or ionic radii, whether partially or fully ionic or covalent. For example, the crystal ionic distances of all alkali halides were shown to be sums of the  $\Phi$ -based ionic radii. When the ion-water distances were plotted against the above  $\Phi$ -based ionic radii, linear relations were found. This enabled the assignment of exact ionic radii in water, and to show that the hydration bond lengths of O (oxygen coordination bond) with cations and of H (hydrogen bond) with anions are constants. Simple integral multiples of the cationic radius,  $d(H^+) = d(HH)/\Phi^2$ , and the covalent radius of H, were found to quantitatively account for the lengths of the hydrogen bonds in many inorganic and biochemical groups."

At the occasion of the 3rd IUPAP *International Conference on Women in Physics* 2008, Seoul, Korea, Raji Heyrovska and Saraswati Narayan (Stevenson University, MD) issued a poster entitled "*Atomic Structures of Molecules (are) Based on Additivity of Atomic and/or Ionic Radii*". This shows the Golden ratio present in anionic & cationic radii, anionic bonds and ANY ATOM. This is also true, of course, for the 6 atoms building the 20 amino acids.

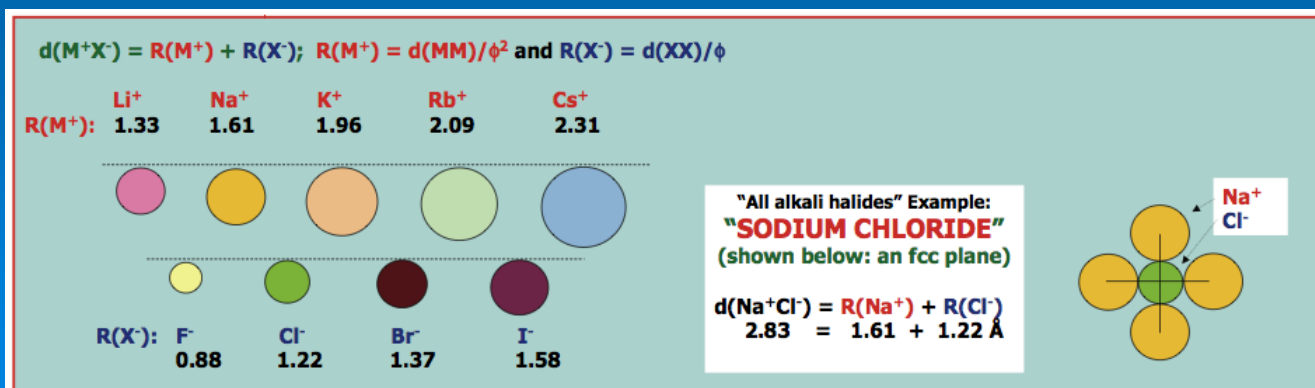

← Example of completely ionic bonds: the alkali halides.



<http://precedings.nature.com/documents/3292/version/1>



## SG203.6.11.1 Golden Implosion (1) Meet Dan Winter

Dan Winter is regarded as one of the most dynamic cutting edge scientists and global thinkers of our times. I like to describe him as a bio-cosmic scientist who managed to keep his eyes twinkling while constantly formulating breakthrough ideas and concepts about the Phi-based inter-connectedness of all things, the profound nature of our "Golden" Oneness and the urgency to re-invent bio-harmonic solutions & technologies on a global scale.

An electrical engineer by education and an accomplished keyboard musician, Dan became a pioneer and champion of Sacred Geometry, freely sharing with the world astounding graphic animations that bring home the unique function of the Phi ratio in the harmonic structuring of the universe. An extraordinarily prolific creator, Dan's web presence at [www.goldenmean.info](http://www.goldenmean.info) is impressive. He also has written several books as well as produced dozens of videos, dvds and web movies.

As a true Renaissance man, Dan, with a powerful sense of the bridges between the worlds, draws on latest science, his own lab experiments, ancient wisdom, mythology, galactic history, geomancy, metaphysics, sacred architecture, popular culture and more... in order to teach his many audiences how to take a brand new look at their belief systems & consciousness levels and inspire them to become proactive agents of global transformation. He is calling to humanity to re-invent science, mathematics, biology, architecture, environments, agriculture, arts, cultures... in the new context of global harmony based on the Golden ratio he has uncovered to be related to the Plank time constant.

A foremost authority on the scientific nature of consciousness, Dan winter focused on *coherent emotion*, as applied to higher functions of the heart. His inventions of the *HeartTuner* and the *BlissTuner* have earned him credit for coining the term Heart Coherence. (See further).

In 2009, Dan Winter has been co-creating the first *Breakthru Technologies Conference* in Calgary, Canada. →

### The purposes are:

- To bring together the world leading team of scientists who are on the cutting edge of fractal field technologies
- To develop innovations in agriculture, technology, energy systems, sustainability, health, and education and provide market support for key projects.
- To facilitate collaboration between visionaries, scientists and pioneers.
- To promote robust science and hardcore testing, validation and analysis.
- To develop regenerative projects that offer sustainable living systems.

[FractalField.com](http://FractalField.com)

[Breakthu-technologies.com](http://Breakthu-technologies.com)

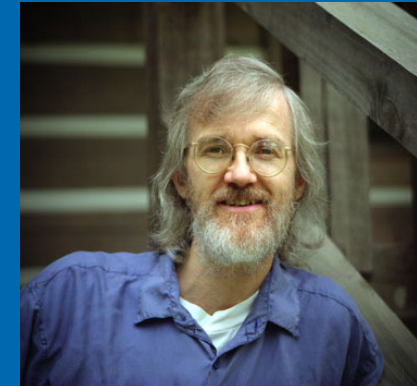

↑ Dan Winter

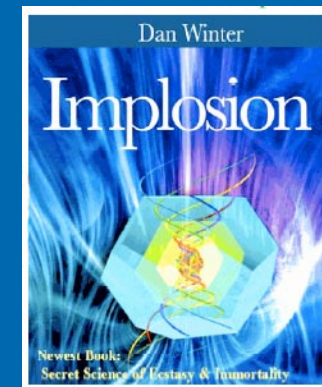

↑ Cover of Dan Winter's *Implosion*

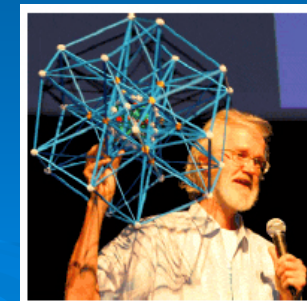

# SG203.6.11.2 Golden Implosion (2) Phi Dodeca Animations

Images & Animations: Dan Winter. [www.goldenmean.info](http://www.goldenmean.info)

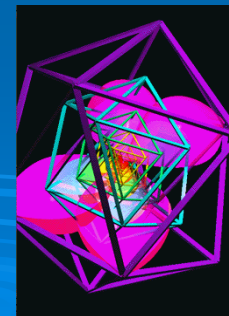
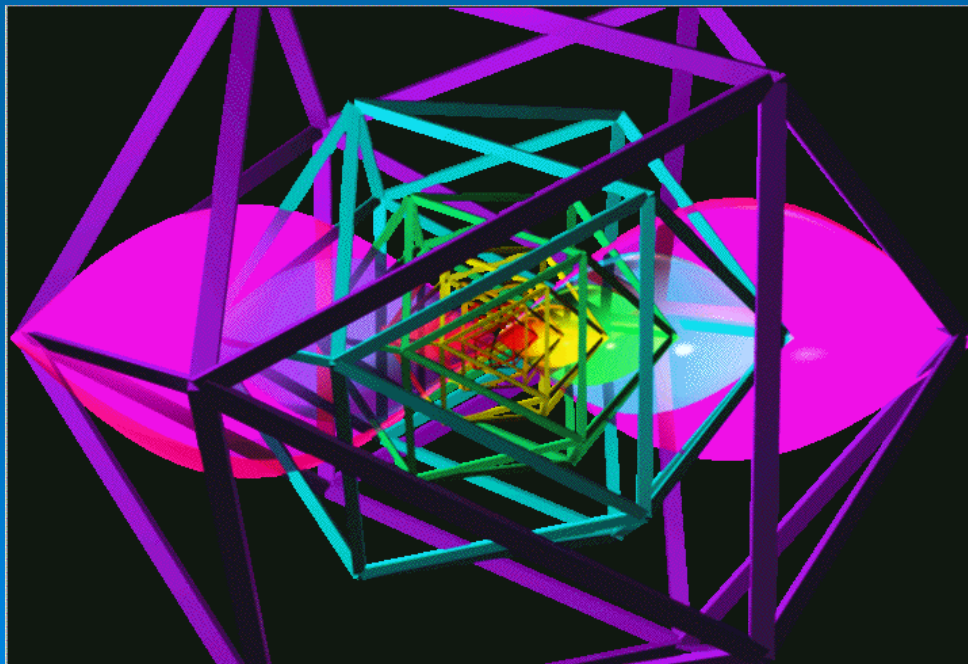
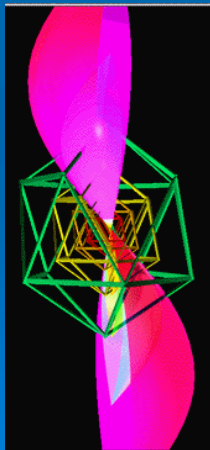
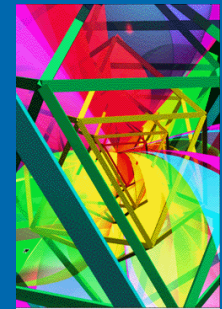
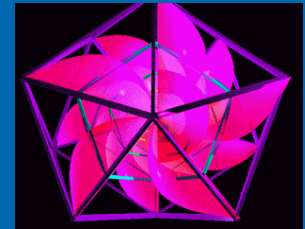
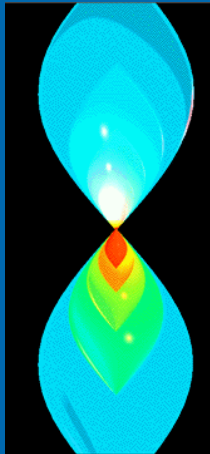

## SG203.6.11.3 Golden Implosion (3) Fractal Unified Field

*"Fractal Field Unified Theory" is the name used by Dan Winter to combine the two principles of Fractality and the Golden Mean. It could also be called the "Golden Fractal Field Theory".*

Here are the explanations given on the site [www.fractalfield.com](http://www.fractalfield.com)

*"An inspiring new order of pure scientific principles, the Fractal Field operates and expresses itself through phase conjugation.*

*Because a fractal is infinite compression, it is what spans the gap between the symmetries of the very small and the very large. Fractals exhibit self-similarity: their inner structure has the same pattern as their outer structure - like a pine cone or a fern tree. Just like fractality describes the geometry of waves of energy or charge, fractals manifest as wave patterns that evolve ad infinitum, like an encoded thread linking large spirals to infinitely smaller ones.*

*The concept of SYMMETRY is common to the Fractal Field and PHI. Symmetry is the language of nature, on all scales. Quantum physicists explain the zoo of fundamental particles as different facets of a symmetrical object. Relativity too is an expression of the symmetries that exist between space & time. The Fractal Field Unified Theory illustrates that the perfect, infinite symmetry sought by physicists pre- and post-Einstein is a fractal and Golden ratio based conjugate field.*

*Practically speaking, PHASE CONJUGATION describes nature's ability to organize and correct itself on a global scale. It is implosion perfected by the Golden ratio, and the path that energy takes from chaos into life.*

*Dan's unified field theories have formed the basis of notable research around the world. In his book Implosion: the Secret Science of Ecstasy and Immortality, Dan has proposed a radical and dramatically exciting answer that is deeply challenging the community of physicists. Various physicists have joined him to explore the unified physics of the Golden ratio and test his original hypothesis that the Golden ratio-based self-similarity is the electrical cause of gravity."*

*The hypothesis that the Golden Ratio is the essence of fractality  
- and thereby the root cause of gravity, along with all centripetal forces -,  
is groundbreaking  
in that it links waves of all kinds  
to a single fractal heart.*

**Here is the way PHASE CONJUGATION -  
as constructive Adding & Multiplying of Self Similar  
Wave Fronts ... CAUSES - Self Organization,  
Gravity, Perception, Color, and Bliss...**

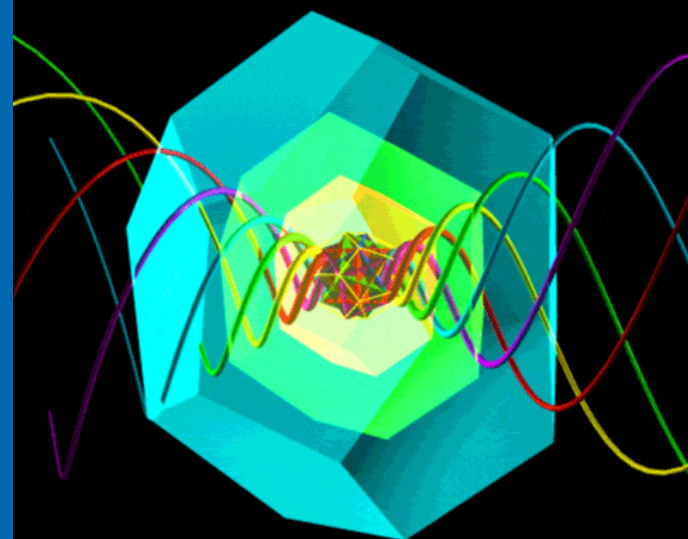

**Because there is a place of perfect Plasma Compression  
at the Core - the Implosive Inertia Eliminates all Waves  
Which are out of phase- so it appears to Self Organize.**



## SG203.6.11.4 Golden Implosion (4) The Planck Connection

In physics, Planck units are physical units of measurement defined exclusively in terms of five universal physical constants in such a manner that these five physical constants take on the numerical value of *one* when expressed in terms of these units. Originally proposed in 1899 by German physicist Max Planck, these units are also known as *natural units* because the origin of their definition comes only from properties of nature and not from any human construct. Unlike the meter and second, which exist as fundamental units in the SI system for historical reasons (in *human history*), the *Planck length* and *Planck time* are conceptually linked at a fundamental physical level. There are five base Planck units for: length, mass, time, charge and temperature.

Using the results recently obtained by Raji Heyrovska (see above) showing the GOLDEN RATIO in the radii of hydrogen and many related ions, Dan Winter figured out their relationship to Planck's length multiplied by a power of the Golden ratio PHI.

*The THREE known GOLDEN RATIO radii of HYDROGEN actually are a PERFECT MULTIPLE of GOLDEN RATIO times the PLANCK LENGTH (to within about 1/1000 accuracy).*

Another Planck connection found by Dan Winter is that the inverse of Planck's Time constant divided by a power of the Golden ratio yields the special "*Kansius*" frequency to split hydrogen (the "ringing frequency" of hydrogen).

$$\frac{\left( \frac{1}{\frac{\text{Planck Time Constant}}{1.35125 \cdot 10^{-43}}} \right)}{\text{Golden Mean } 1.618033989^{171}} = 13.563688 \text{ Mhz}$$

The (PGM) Palladium sputtering frequency AND (Kansius) key frequency to SPLIT HYDROGEN!!

Given Planck's Length =  $1.616252 \times 10^{-35}$  meter  
and Golden ratio =  $\Phi = 1.618033989$

Planck's Length  $\times \Phi^{116} = .282537$  Angstrom  
= the First Radii of Hydrogen

Planck's Length  $\times \Phi^{117} = .457154$  Angstrom  
= the Second Radii of Hydrogen

Planck's Length  $\times \Phi^{118} = .739691$  Angstrom  
= the Third Radii of Hydrogen

Heyrovska found: .28 Angstrom, .46 Angstrom, .74 Angstrom.  
(1 Angstrom =  $10^{-10}$  meter)

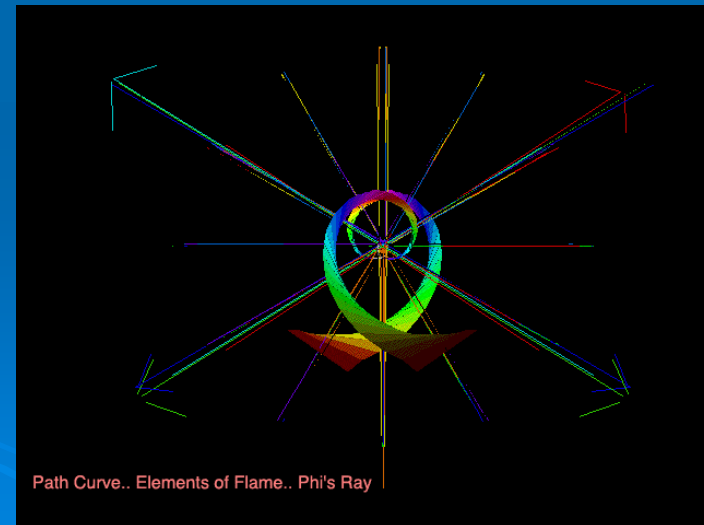

Path Curve.. Elements of Flame.. Phi's Ray

↑ Path curve of the Golden Sp[iral] Dan Winter animation.

## SG203.6.11.5 Golden Implosion (5) Heart Phi Coherence & Bliss

Dan Winter was a pioneer in replicably measuring the coherent ordering of the heart's harmonics during the feeling of compassion. Dan's cutting edge research was subsequently taken up by other scientists and institutions such as the HeartMath Institute.

In **◆SG204**, we will expand on this fundamental research about *Phi Coherence and Compassion* and their effect on DNA & the immune system. We will also present the new Heart Wave research about *Heart Rate Variability*.

As a brief introduction, let us comment on Dan Winter's dream: the "*Heart Beat Earth Project*" for Global Coherence. Dan believes that we can teach self-awareness on the internet using his inventions of the *HeartTuner & BlissTuner* as biofeedback loops to synchronize the Golden Phi heartwaves at the peak moment of compassion. As we know, the Phi ratio as a wave can add & multiply itself in an infinite fractal way. We also know from our common human experience (and now from laboratory experiments) that the Phi wave can be experienced outside of oneself through love & compassion. Dan's experiments with humans sending love to trees have shown that the trees respond at a distance by entraining and aligning in phase with the heart, at moments of peak emotion.

This confirms other studies about the *Biology of Belief*: our choices to FEEL COHERENTLY may well be our best and fastest technology for healing ecosystems and human systems and co-creating harmony in the world. In Dan's vision, as thousands of hearts are inter-connected via the internet, a database records and displays heartbeats registering the signature for compassion: by focusing around the planet our collective intention through compassion, the evidence suggests many possibilities of planetary rebalancing and re-greening, including atmospheric stabilization. This approach demonstrates how the collective power of hearts entrained to the feeling of healing compassion can reshape the world.

This is really nothing new: all mystical wisdoms and all shamanistic traditions has been teaching & practicing such from time immemorial. Except now, we can prove it to our rational mind and thus help the new scientific paradigm to expand beyond the old courtyard boundaries.

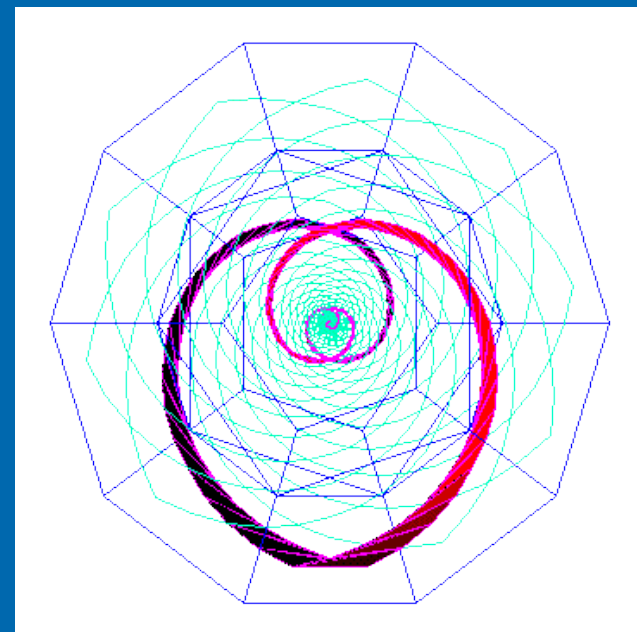

↑ The fractal Heart. Dan Winter.

### Dan's discovery & message are simple:

The Phi COHERENCE that seems to be sustaining the universe all the way to the DNA itself must also be consciously modeled on a human level and taken up by human intention focusing on the power of the heart and the harmonic balance of the auric field & body systems. This is how we re-enter oneness & bliss: applying the Golden self-similarity all the way to human thoughts and feelings. This is just plain Sacred Geometry: the small is to the large as the large is to the whole.

According to Dan, this PHI Coherence as a fractal geometry of compression, is what the Egyptians called the KA and what creates a vehicle for memory into death and the lucid dream states. This immortalizing potential in the charge created by blood on fire (or on "light") with bliss is the real message of ancient wisdom & religion, in their perception of spiritual oneness.

Dan Winter calls this the *physics of the Grail*. The physics is nestedness or embedding (through fractal Phi implosion) and the psychology (or yogic practice) is to redefine pure intention by discovering that what emerges from perfect compression is the only SHAREABLE WAVE.

## SG203.6.12 Spotlights on Phi

In addition to the examples of Phi research given in this & previous chapters of SG203, we list here some links for Golden Ratio research and papers written by keen & dedicated scientists uncovering Phi in all realms of science. We will visit some of them more in detail in upcoming modules. Note that, whereas in the rest of the world Golden Ratio research is welcome, in the US it is still kept by official science outside of the hallways of "true science" and debased as charlatanism - the most recent example being the medieval huntwitch created for Dr. El Naschie.

This is only the surface of what a full team of scientific investigators could bring together. We offer it in hope that it may be of inspiration to look deeper and larger in the direction of this unique ancient-future cosmic fractal constant: PHI.

- Salvatore Giandinoto. *Incorporation of the Golden ratio Phi into the Schrödinger Wave...* [www.metaelmelet.hu/egyelm/abs/Salvatore\\_Giandinoto.pdf](http://www.metaelmelet.hu/egyelm/abs/Salvatore_Giandinoto.pdf)
  - Frank van den Bovenkamp. *Why Phi?* [www.heartcoherence.com/whyphi2007.pdf](http://www.heartcoherence.com/whyphi2007.pdf).
  - Alex Kaivarainen. *Golden-based physics in Finland.* [//arxiv.org/abs/physics/0003001](http://arxiv.org/abs/physics/0003001)
- Tom Bearden. *An extraordinary scientist of the new science paradigm and vacuum technologies.* [www.cheniere.org](http://www.cheniere.org)
  - Bruce Lipton. *Emphasis on "Fractal Evolution".* [www.bruce-lipton.com](http://www.bruce-lipton.com) See SG204.
  - Nassim Haramein. *The Holographic Theory.* [www.theresonanceproject.org](http://www.theresonanceproject.org)
- Harald and Volkmar Weiss. *The Golden Mean as clock cycle of brain waves.* [www.volkmar-weiss.de/chaos.html](http://www.volkmar-weiss.de/chaos.html)
  - Vernon Woolf. *Holodynamics and Consciousness.* <http://www.holodynamics.com/>
    - J. C. Perez. *Golden-based resonance in the DNA.* See SG204
  - MathHeart Institute & Winter. *Phi-based EKG of heart in compassion.* See SG204.
    - Factal Cosmology. *A new burgeoning field.* See **SG301**
    - Garrett Lisi. *Unifield E8 model based on Phi.* [www.garrettlisi.com](http://www.garrettlisi.com)
    - William Tiller. *Physics of Conscious Intention.* [www.tillerfoundation.com](http://www.tillerfoundation.com)
  - Peter Gariaev. *Wave Genetics in Russia. Bio-acoustic & Bio-photonic Signaling.* See SG204
  - Russian research on *Golden Ratio Physics & Biology.* See further: Russian Golden Science.
    - Patrick Flanagan. *Phi-based healing technologies.* [www.phisciences.com](http://www.phisciences.com)
    - Irving Dardik. *The Super-Wave Principle.* <http://www.dardik-institute.org>
  - Matti Pitkänen. *Topological GeoMetroDynamics. Golden Mean in physics* [//tgd.wippiespace.com](http://tgd.wippiespace.com)
    - David Thompson. *QuantumAetherDynamics.* <http://www.16pi2.com>

... and so many others pioneers of a unified cosmic wisdom of harmony...



## SG203.6.13.1 The Mathematics of Harmony

In 2009, an extensive “treatise” was published, in English language, by Ukrainian scientist Professor Alexey Stakhov: *The Mathematics of Harmony*.

This seminal book is the result of 40 years of research & development by A. Stakhov. It re-establishes a welcome bridge with the main focus of ancient science: Harmony and the mathematical understanding of the harmonious organization of the universe. It synthesizes and stimulates further research in the theory and practical applications of the Fibonacci Numbers & the Golden Ratio: in the West, we are not aware of the tremendous work recently done by Slavic scientists on the universality of the Golden Ratio (see the next page *The Slavic Golden Group*).



↑ Logo of the Global Harmony Association (GHA),

founded in 2005 by Leo Semashko. Dr. Stakhov is a Board member. The GHA is active in 48 countries to establish a *civilization of harmony*.

 [//peacefromharmony.org](http://peacefromharmony.org)

Stakhov's work heralds the upcoming reunion of classic mathematics/physics & the mathematics of Harmony recently revealed by the discoveries of Penrose Tiling, the C60 molecule & fullerenes, fractals, quasi-crystals etc...

This timely coming together will in turn reflect itself in science & mathematics education by providing the context of nature to model scientific understanding & technologies.

*“The 21st century is the century of Harmony.” (A. Stakhov).*

Moreover, as already mentioned in the previous section (Fibonacci/Lucas in Science), Alexey Stakhov has made outstanding contributions to mathematics and computer science:

- Generalization of the Golden Proportion
- Hyperbolic Fibonacci & Lucas functions
- Golden Fibonacci Trigonometry
- Fibonacci & Golden Matrices
- Fibonacci computers
- Golden Ratio cryptography.

Stakhov explains that there is a quantitative aspect to the Mathematics of Harmony. It is to be found in Combinatorial Analysis which studies the combinations and connections formed between the elements of some finite set and can be the main mathematic tool for the understanding of the concept of harmony and proportionality.

**“This is the main idea behind (my) research... (I) made an attempt to create the *Fundamentals of the Mathematics of Harmony*, based upon combinatorial analysis”.**

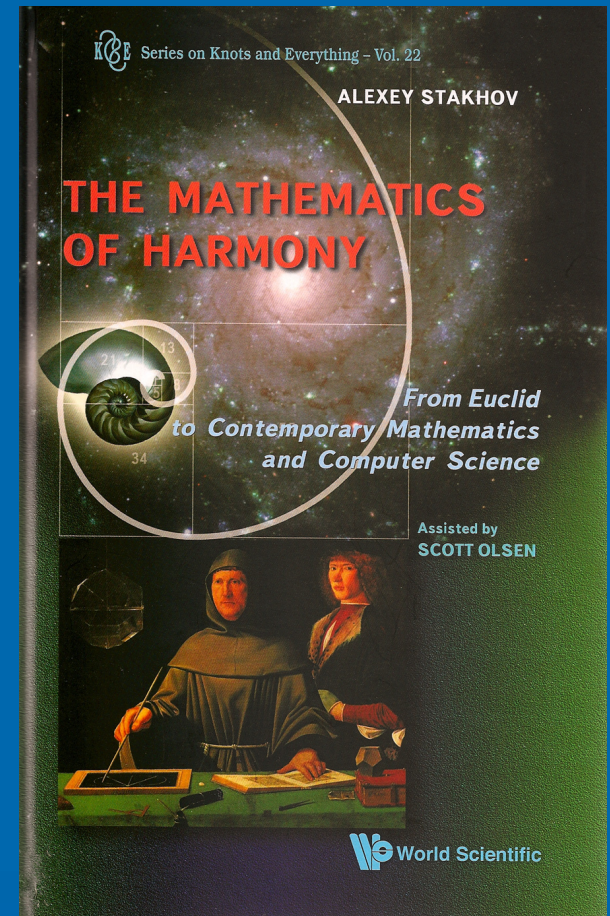

↑ Alexey Stakhov

## SG203.6.13.2 The Museum of Harmony

The concept of the Museum of Harmony is another contribution of Alexey Stakhov. In 2001, A. Stakhov and his daughter Anna Sluchenkova created a website ([www.goldenmuseum.com](http://www.goldenmuseum.com)) for a currently virtual and, in the potential future, actual Museum of Harmony and the Golden Section. This is a wonderful global educational project of "peace on earth" and welcome convergence of science. Religions, traditions of wisdom, metaphysics, art, music, culture, technology... A project aiming at unifying all of humanity around the New Paradigm knowledge of a Golden Fractal Cosmos. We quote below extracts of the Introduction to the Museum.

*"... the authors of the Museum exhibits are Nature, God, Space, the great artists, poets, scientists of the past and modern times. All history of mankind, our Earth and Universe are connected to our exhibits.*

*The technological progress has passed, in its historical development, many stages from the Babylonian and Egyptian cultures to the 'Scientific-Technological Revolution' of the 20th century and has come in the 21st century, which opens up a new epoch in the history of mankind: the epoch of Harmony.*

*Our Museum is truly unique, as, on the one hand, it will tell to you about the Golden Section applications in all domains of Nature, Art and Culture, and, on the other hand, it will introduce you to applications of the Golden Section in ancient and modern science. Conditionally the Museum can be divided into two parts: cognitive and scientific. The former part pursues the cognitive purpose to acquaint all people, including the schoolboys, students, teachers, homemakers, engineers, specialists of various scientific directions and representatives of all arts with surprising discoveries of ancient science - the Golden Section and its miscellaneous applications. The scientific part of the Museum is intended for scientists. Its main purpose is to tell about modern scientific discoveries based on the Golden Section, in particular, about the "Mathematics of Harmony" and its applications to contemporary science.*

*Our Museum is developing its structure and we invite each visitor to share in its creation and development. We will consider all your ideas and proposals. Pursuing the purpose to popularize our Museum and to spread knowledge about the Fibonacci numbers and Golden Section we are ready to offer educational services and to deliver lectures, at various degrees of complexity, about the Fibonacci numbers and the Golden Section.*

*And at last about our Main Purpose. We, certainly, dream of the physical realization of the Museum as a grandiose architectural temple, in which all works of Nature, Science and Art based on the Golden Section will be collected. We suspect, that in the architectural plan of our Museum glorifying the Harmony of the Golden Section, all ideas of the ingenious architects and sculptors of antiquity and modernity will be embodied. And we call on all architects and all people to accept an active participation in the realization of our proposal. Certainly, without financial support it would be impossible to realize such a project. We would also like to create a 'FUND OF THE GOLDEN SECTION' to support financially the unique scientists of our planet who study Fibonacci numbers and Golden Section in their professional fields.*

***We welcome you to visit our "Virtual Museum of Harmony and Golden Section."***

*"It is impossible to imagine future progress in physical & cosmological research without taking in consideration the Golden Section... (The recent discoveries) point to the Golden Section as a kind of 'metaphysical knowledge', a 'pre-number' or 'universal code of nature' which could become the foundation for the future development of science." (A. Stakhov)*

- 2003: A. Stakhov founded the International Club of the Golden Section (ICGS).
- 2005: A. Stakhov founded the Institute of the Golden section IGS).

 [www.goldenmuseum.com](http://www.goldenmuseum.com)

# SG203.6.13.3 The Slavic/Russian Golden Science (1)

In his book *Mathematics of Harmony* and website *The Museum of Harmony*, A. Stakhov brings to the attention of western scientists the outstanding contributions of what became known as the *Slavic Golden Group*. The term "Slavic" covers Ukraine, Russia, Belarus & Poland.

In 1961, Russian mathematician Nikolay Vorobyov published a popular book (*Fibonacci Numbers*) that inspired a great interest in the subject. While, in the West, the 1980's and 1990's, the scientific interest in Fibonacci Numbers & the Golden Ratio began to arise again with the founding of the Fibonacci Association (1984) and the discoveries of Penrose Tiling, fractals, quasi-crystals, fullerenes etc..., these results were isolated in their own disciplines and not seen or understood as complementary aspects of a new/ancient universal "Science of Golden Harmony", mainly because western science, in the last 2 centuries, has veered to an overly rationalistic / reductionist position in its attempt to control nature and to erase consciousness and "chaos" from scientific enquiry.

In the Russian/Slavic cultures, the rigor of science still allowed for inclusiveness and inter-disciplinary fruitful exchanges, as well as an openness to psychic / mystical experiences. As a result, starting in the late 1970's, soviet science developed both a practical direction of Fibonacci & Golden Ratio research (Fibonacci computers science, Golden Ratio physics, botany, biology & engineering...) and a synthetic, overview approach bringing together all the new emerging research data & discoveries in the larger, coherent understanding of the Golden Mean as a universal code of self-organizing systems on all scales. This openness (rather than the western main science reflex of recoiling and "debunking golden-numberism") now shows itself in the introduction of new educational curricula, in schools and universities, that are rebuilding mathematics and science on a new "universal harmony" base.

In the interesting cyclic way of history, the Russian / Slavic science is both looping back & expanding into the future the ancient vision & dream of Egyptian & Greek philosophers-mathematicians: revealing the harmonious organization of the cosmos. This principle of the numerical harmony of the universe (the so-called "Pythagorean School" view), while appearing & disappearing with the ebbs & flows of history, can be followed as a "golden thread" all through the last 3,000 years. In the West, a "lineage" of great thinkers, artists & scientists have carried the torch of Sacred Geometry: Egyptian architects, Pythagoras, Plato, Euclid, Fibonacci, Pacioli, Da Vinci, Kepler, Bernoulli, Lucas, Klein, Fuller... and now a new wave of researchers, the world over, who are no longer isolated pioneers but come together to point again to what was the precious core of ancient wisdom, in the words of Russian philosopher Alexey Losev:

*"From the point of view of all antique cosmology,  
the universe is a certain proportional whole  
that is subordinated to the law of harmonious division,  
the Golden Section".*

Here, we want to extend our thanks to the Russian/Slavic school of contemporary Harmonic Science.  
And we want to specially thank Professor Alexey Stakhov for his life-long determination  
in sharing this knowledge and for his pioneering mathematical discoveries,  
thus preparing the emerging Golden Cosmic Science.

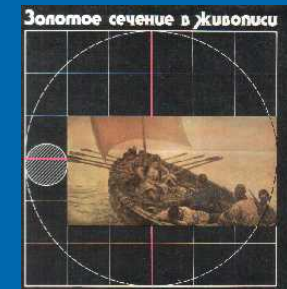



## SG203.6.13.4 The Slavic/Russian Golden Science (2) Timeline

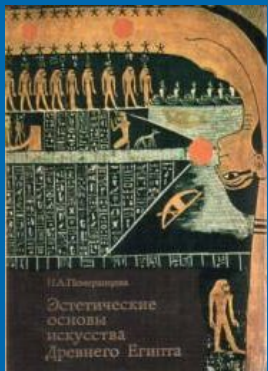

- 1961. Nikolay Vorobyov. *Fibonacci Numbers*.
- 1977. A. Stakhov. *Algorithmic Measurements Theory*. (Measurements based on Fibon Numbers).
- 1978. Butusov, K. P. *The golden Ratio in the Solar System*.
- 1979-95. Stakhov et al. *Soviet Fibonacci Computer Project*. 65 foreign patents.
- 1984. Eduard Soroko. *Structural Harmony of Systems*. (Reviews the Pythagorean idea of the numerical harmony of the universe).
- 1984. A. Stakhov. *Codes of Golden Proportion*. (New number systems).
- 1985. Natalia Pomerant. *Aesthetic Foundations of Ancient Egypt*. (Role of Golden Section in Egypt).



- 1986. Jan Grzedzielski. *Energy-Geometry Code of Nature*. (The Golden Mean as the proportion of thermo-dynamic equilibrium in self-organizing systems.)
- 1986. Kovalev, F. V. (Russian art teacher). *The Golden Section in Painting*. (Manual for artists).
- 1990. Nikolay Vasyutinsky (Ukrainian scientist). *The Golden Section: Three Approaches to the Nature of Harmony*.
- 1992. *First International Seminar on the Golden Section and Problems of System Harmony*. Kiev.
- 1993. *Second International Seminar*. Kiev. 1994, 1995, 1996: Follow-up Seminars. Stavropol.
- 1994. Oleg Bodnar. *The Golden Section and Non-Euclidian Geometry in Nature & Art*. (New geometric theory of phyllotaxis).
- 1996. A. Stakhov. Seminal Lecture. *The Golden Section and Modern Harmony Mathematics*.
- 1997. Tsvetkov (Russian biologist). *Heart, Golden Section & Symmetry*. (Role of Golden Ratio in optimizing heart activity).
- 1998. Professor Korobko (Russia). *The Golden Proportion and Problems of System Harmony*. (Comprehensive manual for universities and college teachers).
- 1999. A. Stakhov et al. *Introduction to Fibonacci Coding & Cryptography*. (Fibonacci matrices).
- 2000. Shevelev (Russian architect). *The Meta-Language of Living Nature*.
- 2001. A. Stakhov and A. Sluchenkova. Website: *Museum of Harmony and the Golden Section*. [www.goldenmuseum.com](http://www.goldenmuseum.com)
- 2003. International Conference. *Problems of Harmony, Symmetry and the Golden Section*. Vinnitsa (Ukraine).
- 2003. A. Stakhov. *Hyperbolic Fibonacci & Lucas functions*. (A new mathematics for the living nature).
- 2005. Petrunenko, V. V. *The Golden Section in Quantum States and its Astronomical & Physical Manifestations*.
- 2006. Soroko, E. M. *The Golden Section, Processes of self-organization and Evolution of System*. (Introduction to a general theory of System Harmony).
- 2006. Vladimirov, Y. S. *Metaphysics of the 21st Century*. (Golden Mean applications in modern science).
- 2006. Petoukhov, S. V. *Metaphysical Aspects of the Matrix Analysis of the Genetic Code and the Golden Section*. (Discovery of the "golden geno-matrices").
- 2005. Creation of the *Institute of the Golden Section*.
- 2006. Stakhov, Sluchenkova & Scherbakov. *The Da Vinci Code & Fibonacci Series*.
- 2009. A. Stakhov. *The Mathematics of Harmony*. (A new inter-disciplinary science).



Note: it is interesting to see that Russian / Slavic scientists are overtly using the term "Golden Section" in their scientific research publications, without being "ashamed", fearing to "lose their jobs" or enduring the "ridicule" of their colleagues.

## SG203.6.14 Cosmic Harmonics

### The Golden Fractal Field Science of Oneness

As we have seen in SG202, the invention in India and the slow but inexorable adoption in the West of the current number system (1-9 plus zero) is what made possible the scientific materialism of the present western/international culture. It certainly allowed for an extraordinary explosion of technologies and life styles, but also brought about a host of dire consequences: a science & philosophy of material reductionism & determinism, the increased psycho-social alienation from wholeness and meaningfulness, a shift of control from religious to massive political-financial systems backed by blind legal-military enforcement, and the casual and short-sighted exploitation of nature & people as commodities...

A personal & collective mindset of ego-based competition and a separation from the oneness of life and the wholeness of the universe have been the insidious diseases of this modern culture now facing prompt replacement due to failure. A “spontaneous evolution”, mandated by the now extent 6th mass extinction, is brewing and birthing a renewed global civilization of expanded consciousness.

The foundation of this New Paradigm is an awareness of the universe based on harmonic inclusiveness, i.e. oneness with each other, with the web of life and with the spirit of the universe. We are duly invited to re-enter the dance with the multi-dimensional Beingness of the universe. This new paradigm requires new tools for perceiving expanded realities: new phi-fractal mathematics & number systems, new non-local quantum physics of omni-connectivity, new music-color scales, new time navigation and calendar... All other aspects of civilization will follow on these premises: philosophical & spiritual systems, languages, economics of sharing, architecture, arts, medicine & health, diets of living foods, life styles of peace & harmony, psycho-spiritual well-being, new families & communities...

A phenomenal display of human creativity is awaiting us as we enter this exciting & inciting adventure of the cosmic co-creation of a Golden Age on Earth. It is premised upon adopting a new mathematical language derived from the fractal, globally coherent, phi-based, harmonic scale structure and interactive non-locality of the universe as we are starting to understand it at the cutting edge of science and consciousness exploration.

*Galactic-level science & wisdom are the gifts and returns of embracing this ancient-future golden field and tending the Earth as a Golden Garden of celebrative creation.*

*As we enter the Garden, we are regaining our essential sense of belonging to larger wholes.*

*We are vortexing into the super-spirals and hyper-mandalas of the harmonic orchestra playing the music of human evolution.*



“Emergence”

By Hopi artist  
“Walking in Harmony” Michael Kabotie.  
[www.kabotie.com](http://www.kabotie.com)

# SG203B.Ca Conclusion

In this SG203 module, we have briefly surveyed the emergence of a new cosmic science applying the ancient insights of Sacred Geometry to a new paradigm of consciousness and perception of reality. We have glimpsed a new post-quantum physics of non-local hyper-conductivity, a new awareness of phi-based fractal inter-connectedness, a new mathematics of harmony, a new biology of quasicrystalline conscious intention, new technologies of self-sustaining implosion... A new cosmic evolutionary code is being rapidly woven into the nascent global culture of a spirited & co-creative humanity. In this larger perspective, 'new' also means 'perennial'.

Blocks of new knowledge are now rapidly moved around on the scientific paradigm chessboard.  
Watch for a whole new picture to come into view!

We are called as the human species to enter in conscious communion with our smaller & larger selves.  
We are called to ascend the 'fractalline' ladder of the Golden Ratio,  
as the harmonic scaling constant of the universe.  
We are called to inherit again a wisdom understanding of the universe from a cosmic perspective.

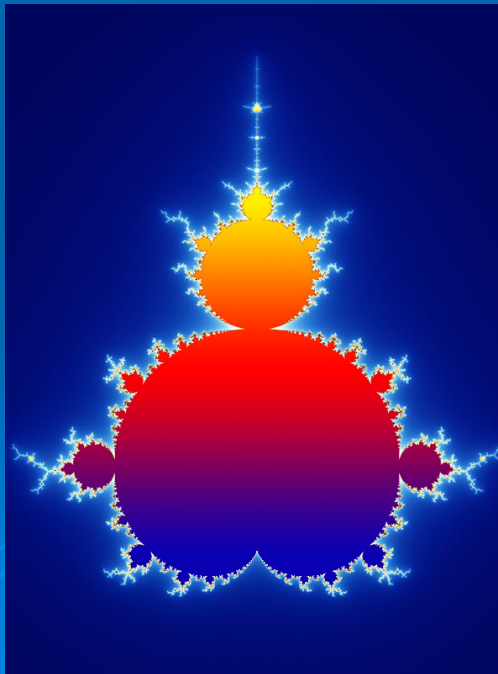



# **SG203B.Cb Online SG School Curriculum: Intro & Intermediate**

## **Sacred Geometry Introductory Level: 8 Modules**

<b>SG 101</b>	<b>Intro I</b>	<b>Sacred Geometry: Universal Order &amp; Beauty</b>
<b>SG 102</b>	<b>Intro II</b>	<b>History &amp; Traditions of Sacred Geometry</b>
<b>SG 103</b>	<b>Intro III</b>	<b>Sacred Geometry: A Grand Tour</b>
<b>SG 104</b>	<b>Intro IV</b>	<b>PHI: the Golden Ratio &amp; the Fibonacci Series</b>
<b>SG 105</b>	<b>Intro V</b>	<b>The Golden Rectangle &amp; Golden Spiral</b>
<b>SG 106</b>	<b>Intro VI</b>	<b>Pentagons, Pentagrams &amp; the Penta-Modules</b>
<b>SG 107</b>	<b>Intro VII</b>	<b>The Five Platonic &amp; 13 Archimedean Solids</b>
<b>SG 108</b>	<b>Intro VIII</b>	<b>The Vesica Piscis: Cosmic Womb of Creation</b>

## **Sacred Geometry Intermediate Level: 8 modules**

<b>SG 201</b>	<b>Interm I</b>	<b>The Monochord, Music &amp; Cymatics</b>
<b>SG 202</b>	<b>Interm II</b>	<b>The Power of Archetypal Numbers</b>
<b>SG 203A</b>	<b>Interm IIIA</b>	<b>Sacred Geometry Resurgence in Science - Part 1</b>
<b>SG 203B</b>	<b>Interm IIIB</b>	<b>Sacred Geometry Resurgence in Science - Part 2</b>
<b>SG 204</b>	<b>Interm IV</b>	<b>PHI in the Human Body, Biology &amp; DNA</b>
<b>SG 205A</b>	<b>Interm VA</b>	<b>The SG of Nature - Part 1: Plants &amp; Phyllotaxis</b>
<b>SG 205B</b>	<b>Interm VB</b>	<b>The SG of Nature - Part 2: Animals &amp; Minerals</b>
<b>SG 207</b>	<b>Interm VII</b>	<b>SG in Architecture, Sacred Sites &amp; Green Design</b>

## SG203B.Cc Online SG School Curriculum: Advanced

### Sacred Geometry Advanced Level: 8 modules

SG 301	Adv I	Golden Cosmos: Planets, Stars & Cosmology
SG 302	Adv II	SG in Art, Culture & Creativity
SG 303	Adv III	Universal Symbols: Primordial Knowledge
SG 304	Adv IV	Labyrinths: a Mini-Pilgrimage to Self
SG 305	Adv V	Mandalas & Yantras: Sacred Vortices
SG 306	Adv VI	Languages & Gematrias: Sacred Communication
SG 307	Adv VII	Sacred Geometry in the Healing Arts
SG 308	Adv VIII	Harmony on Earth: Science & Consciousness of Harmony

*Upon completion of each level (Introductory, Intermediate & Advanced), a Certificate of Graduation from the Sedona School of Sacred Geometry will be presented to certification Students.*

*Postgraduate seminars on current Sacred Geometry research, discoveries & updates will be organized in harmonic time.*

*Questions: [phi@schoolofsacredgeometry.org](mailto:phi@schoolofsacredgeometry.org)*

# SG203B.Cd StarWheel Blessing

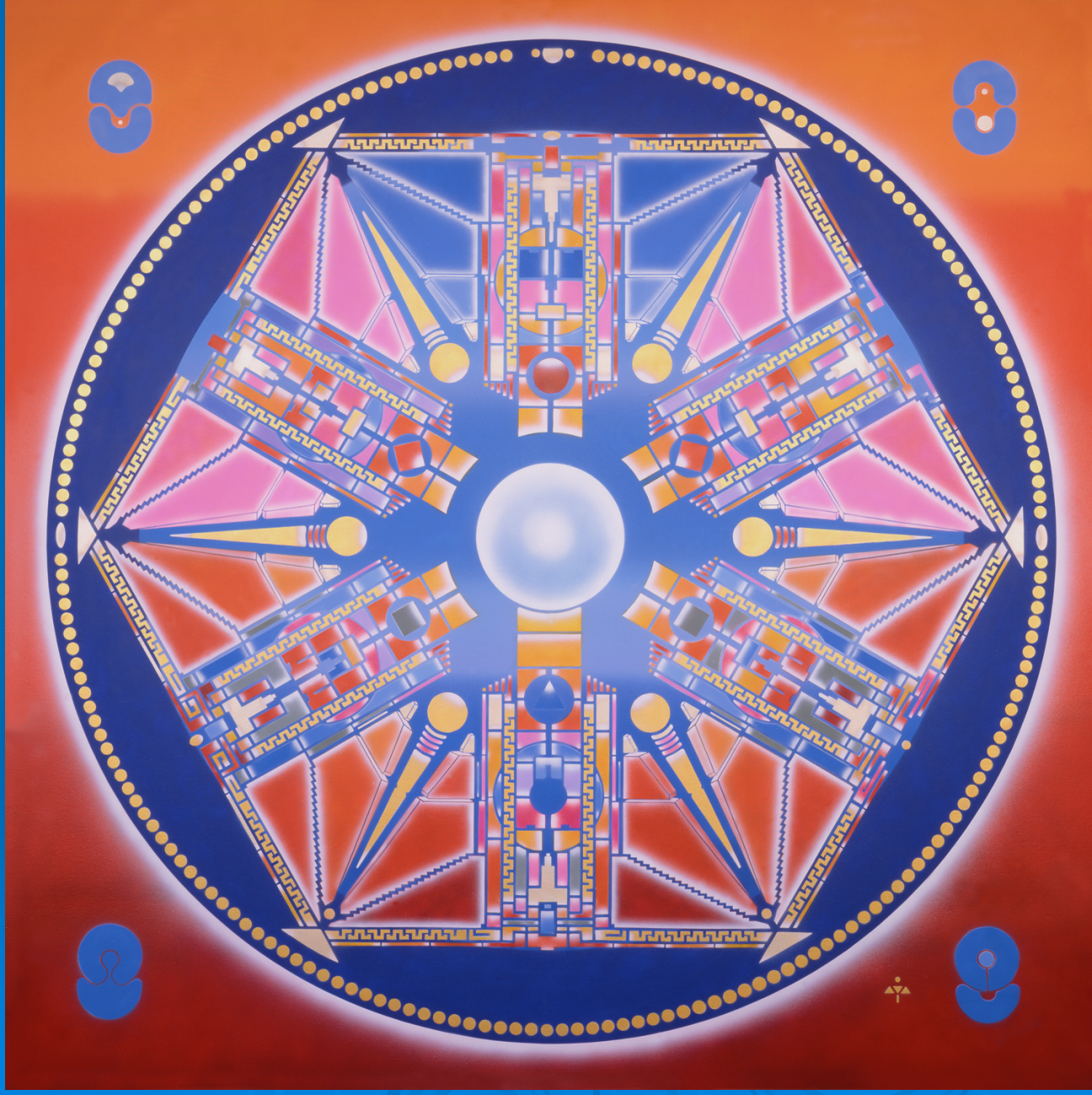

SW#94. Sol-3 Mag" . [www.starwheels.com](http://www.starwheels.com)





## SG203B.Ce Contact Info

**Sedona School of Sacred Geometry**  
[www.schoolofsacredgeometry.org](http://www.schoolofsacredgeometry.org)  
[phi@schoolofsacredgeometry.org](mailto:phi@schoolofsacredgeometry.org)  
PO Box 3714, Sedona, AZ 86340

**StarWheel Mandalas by Aya**

[www.starwheels.com](http://www.starwheels.com)  
[www.starwheels.com/infopage.php?pagename=starwheelgallery](http://www.starwheels.com/infopage.php?pagename=starwheelgallery)  
[aya@starwheels.com](mailto:aya@starwheels.com)

**Our non-profit: [www.starwheelfoundation.org](http://www.starwheelfoundation.org)**

[www.starwheelfoundation.org/index.php?p=globalecocampus](http://www.starwheelfoundation.org/index.php?p=globalecocampus)  
[www.starwheelfoundation.org/index.php?p=acroyoga](http://www.starwheelfoundation.org/index.php?p=acroyoga)  
[www.starwheelfoundation.org/index.php?p=poona1hbooks](http://www.starwheelfoundation.org/index.php?p=poona1hbooks)  
[www.starwheelfoundation.org/index.php?p=tre Sponsorship](http://www.starwheelfoundation.org/index.php?p=tre Sponsorship)

**Our online store: [www.starwheelmandalas.com](http://www.starwheelmandalas.com)**

[www.starwheelmandalas.com/index.php?p=originals](http://www.starwheelmandalas.com/index.php?p=originals)  
[www.starwheelmandalas.com/index.php?p=wisdomcards](http://www.starwheelmandalas.com/index.php?p=wisdomcards)  
[www.starwheelmandalas.com/index.php?p=deck1](http://www.starwheelmandalas.com/index.php?p=deck1)



**On Facebook: Aya Sheevaya**  
**FB Group: Sedona School of Sacred Geometry**

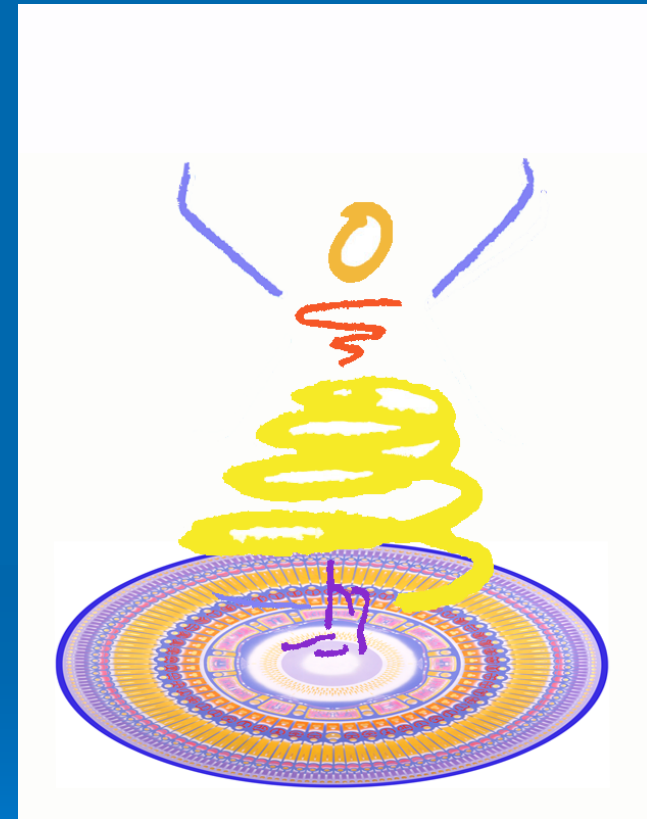

Φ celebration



## SG203B.Cf About Aya

A native of France, Aya is a visionary artist and celebration yogi who has dedicated his life to serve humanity and to develop sacred arts education. In his late 20's, Aya realized that his professional life in the French diplomatic service was not fulfilling his heart's desires; he quit everything to go on an extended vision quest. His path took him around the world to visit a variety of sacred sites & cultures and to receive inspiration from many teachers.

In 1985, in Santa Monica, CA, Aya was gifted with a spiritual vision prompting him to create a series of 108 airbrushed neo-mandala paintings: the "StarWheels". The StarWheels, a happy family of vibratory flowers for the Earth, are looking for sacred spaces to be graced with their presence... ([www.starwheels.com](http://www.starwheels.com) / [www.starwheelmandalas.com](http://www.starwheelmandalas.com))

Moving to Sedona, Arizona, in 1997, Aya has been involved with sacred arts classes & events, mandala creation, Sedona guided tours, labyrinth making and Sacred Geometry teaching. Aya has presented several StarWheel art exhibits, has sponsored community awareness events at the Sedona Library, has developed, in collaboration with Gardens for Humanity, the Peace Garden arboretum at the Sedona Creative Life Center, was a speaker at the Sacred Geometry Conference (Sedona, 2004), co-designed several labyrinth sites (The Lodge at Sedona, Mago's Ranch...), and was on the management team of the Raw Spirit Festival in 2006 - 2008.

Realizing that Sedona was progressively becoming a global spiritual university for many seekers from around the world, Aya founded in 2005 the Sedona School of Sacred Geometry. The school is offering online access to Sacred Geometry PDF modules, with 17 modules completed so far. In the school's website, Aya states: *"We are living at the extraordinary and exciting times of a global transformation to a higher order of human consciousness... Sacred Geometry is the expression and resurrection of our deep innate wisdom, now awakening from a long sleep: seeing again the all-encompassing, fractal-holographic unity of nature, life and spirit... The keyword is HARMONY."* ([www.schoolofsacredgeometry.org](http://www.schoolofsacredgeometry.org))

Aya's visionary dream, supported by his non-profit educational organization, the StarWheel Foundation, is the co-creation of an international eco-village "The School of Celebratory Arts" - a green, tropical environment encouraging young people of all nations to develop their creative consciousness and thus contribute to a new, spirited, life-respecting global civilization on Earth. ([www.starwheelfoundation.org](http://www.starwheelfoundation.org)).

Since 2012, Aya is dancing the body divine, after his re-discovery of Yoga, Partner Yoga and AcroYoga. Aya is currently the AcroYoga.org Jam coordinator for Sedona and a teacher of yoga swing asanas.

Blessings in Anjali!